

# DeltaV SIS Standalone

This whitepaper provides an overview of Emerson's DeltaV™ SIS standalone solution.

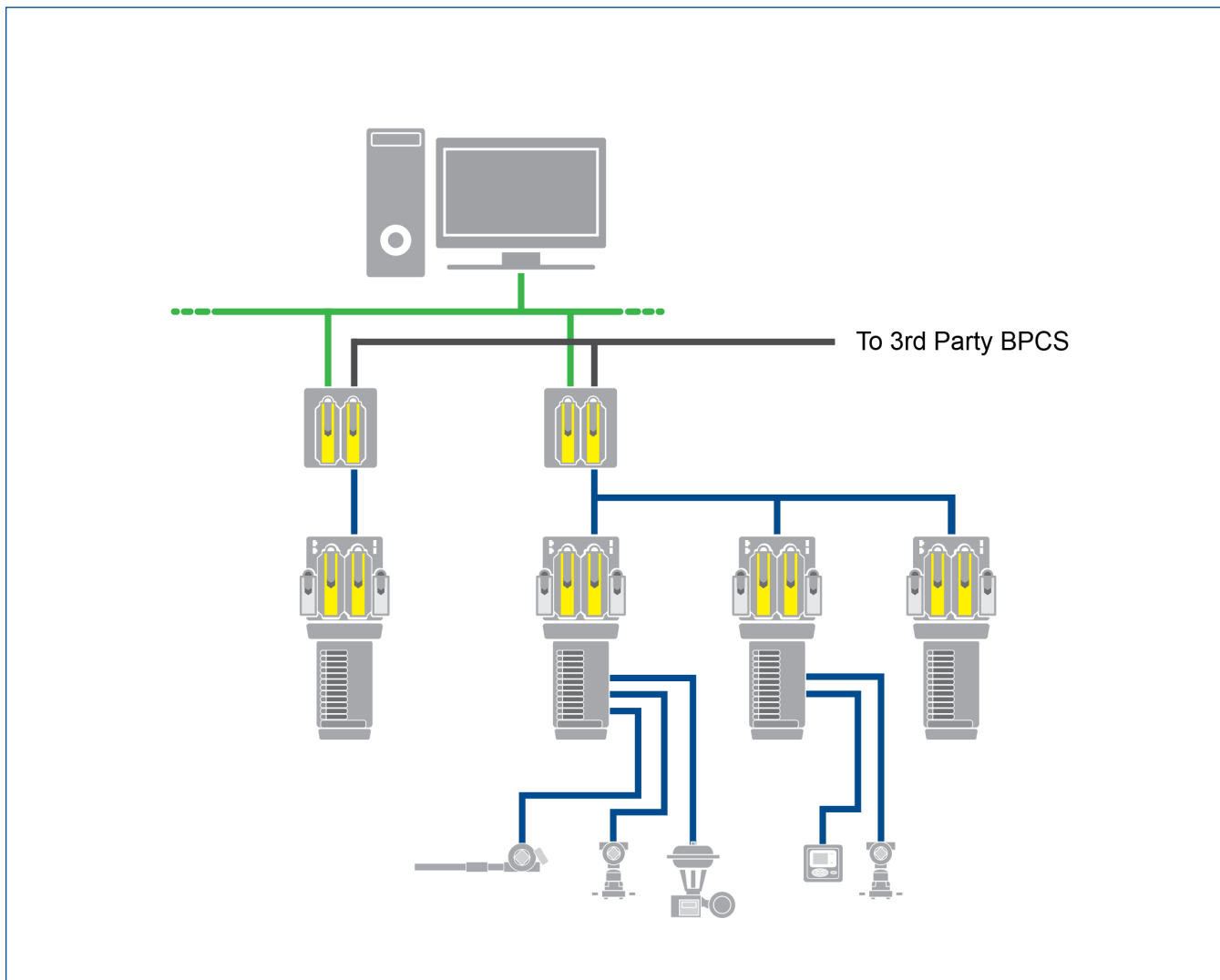

*DeltaV SIS Standalone Architecture*

## Table of Contents

- Introduction** ..... 3
- Architecture Options for Safety Instrumented Systems** ..... 3
  - Separate SIS ..... 3
  - Interfaced SIS ..... 4
- Overview of DeltaV SIS with Electronic Marshalling** ..... 4
  - CHARMs Smart Logic Solver (CSLS) ..... 4
  - Local Safety Network Bridge (LSN) ..... 5
  - Local Safety Network Bridge (LSNB) ..... 6
  - SZ Controller ..... 7
  - Engineering Station ..... 7
  - Engineering Station Hardware ..... 8
  - Alarms and Events ..... 8
  - Non-safety critical I/O and control logic: ..... 9
  - Licensing Options ..... 9
- Interfacing to a BPCS** ..... 11
  - Modbus TCP Interface ..... 11
  - OPC DA Interface ..... 12
  - OPC UA Interface ..... 12
  - Configured to Order (CTO) Cabinets and Field Enclosures ..... 13
  - Cyber security Features ..... 14
- Summary** ..... 14

## Introduction

This whitepaper provides an overview of Emerson’s modern process safety system when deployed as a standalone or interfaced Safety Instrumented System (SIS). This whitepaper is not intended to provide training material on DeltaV SIS, but rather provide an overview of how DeltaV SIS can be utilized as a standalone safety system with or without a 3rd party Basic Process Control System (BPCS).

DeltaV SIS with Electronic Marshalling offers many compelling benefits including modular architecture, increased configuration flexibility, higher availability, extended system life, cybersecurity features, native embedded HART for both Asset Management and diagnostic handling for all signals throughout the system. As a modern safety solution, it expands the visibility throughout the entire Safety Instrumented Function (SIF) by taking advantage of smart instruments and valves, DeltaV SIS continuously monitors the ability of sensors, logic solvers, and final elements to perform on demand. DeltaV SIS assists in stream lining the proof test procedures creating a more efficient process. During modernization projects, DeltaV SIS with Electronic Marshalling allows the most efficient use of available space thanks to the elimination of entire marshalling cabinets.

Emerson’s vision for process safety is the same regardless of the Basic Process Control System (BPCS).

## Architecture Options for Safety Instrumented Systems

ARC has three classifications for the SIS in terms of the connectivity with the BPCS:

- Isolated or separate: The SIS is completely isolated from a BPCS.
- Interfaced: The SIS is interfaced to the BPCS using standard protocols such as Modbus TCP, OPC Data Access (OPC DA), or OPC Unified Architecture (OPC UA).
- Integrated: The SIS shares the same engineering tools and operator environment with the BPCS.

DeltaV SIS can be deployed in any of the above architectures. This whitepaper will focus on the first two options and uses the term standalone to generically refer to these two architectures.

### Separate SIS

In this architecture, the SIS does not share data with the BPCS and it is either completely isolated from the BPCS or deployed without a BPCS. It can have either a permanent engineering station or configured and maintained through the use of a laptop computer. It can have a local Human-Machine Interface (HMI) or not.

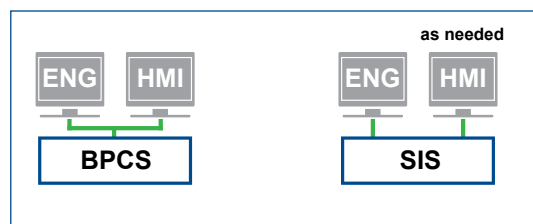

Figure 1 – Separate Safety Instrumented System

## Interfaced SIS

In the interfaced architecture, there's some integration between the SIS and the BPCS, and the most common protocols used are Modbus (RTU or TCP) and OPC (DA or UA). This communication is restricted to monitoring and in some cases operations.

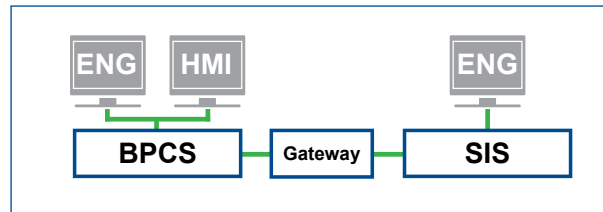

Figure 2 – Interfaced Safety Instrumented System

## Overview of DeltaV SIS with Electronic Marshalling

Emerson is committed to providing SIS solutions for standalone systems. DeltaV SIS has a uniquely scalable modular architecture that is based on the CHARMs Smart Logic Solver (CSLS) and the unprecedented flexibility and ease of use of the Emerson's Electronic Marshalling technology. The following sections describe the Emerson DeltaV SIS solutions including:

- 1) **CHARMs Smart Logic Solvers (CSLS)** to provide safety logic execution
- 2) **Local Safety Network (LSN)** to communicate safety data between multiple CSLSs
- 3) **SZ Controller** to isolate the safety system while maintaining connectivity to the third-party BPCS
- 4) **Engineering Station** to configure and maintain the safety system
- 5) **Local Safety Network Bridge (LSNB)** to transfer safety rated data between multiple LSNs
- 6) **Alarms and Events** capabilities

### CHARMs Smart Logic Solver (CSLS)

DeltaV SIS has a uniquely scalable modular architecture that is based on the CSLS and the unprecedented flexibility and ease of use of Electronic Marshalling. Each CSLS module provides I/O processing, SIL 3-capable logic solving, and diagnostics in a single logic solver. The CSLS supports up to 96 individually configurable channels, allowing flexibility implementing SIFs. For more information about DeltaV SIS, see the DeltaV SIS with Electronic Marshalling product data sheet.

#### For Use in SIL3 Applications

With a safe failure fraction (SFF) greater than 99.8%, the DeltaV SIS CSLS meets the SIL 3 requirements of IEC 61508 even when in a simplex mode. The redundant CSLS is for increased availability and not required for safety.

#### SIF-based Approach

DeltaV SIS design was based on the IEC 61511 concept where a SIS is used to implement one or more SIFs. Unlike other architectures, the DeltaV SIS modular logic solving architecture means the logic solver is no longer a single point of failure of the entire process.

The DeltaV SIS SIF-based approach does not mean that all of the safety logic and I/O have to fit into one logic solver. All input data is made available to every logic solver on the LSN every 50ms the same as the local inputs on every CSLS.



Figure 3 – CHARMs Smart Logic Solver

With the DeltaV SIS logic solver, neither the scan rate nor the execution of a SIF is altered by changes or additions to another SIF or an increase in I/O. DeltaV SIS logic solvers always execute deterministically.

## Diagnostics

The DeltaV SIS logic solvers execute extensive automatic self-testing on a continuous basis to detect potential faults. Faults detected by logic solver diagnostics can be associated with the logic solver itself or associated with field devices, field wiring, or other conditions not related to hardware.

## Integrated HART

HART diagnostics provide much more information on the health of a field device that can be determined from a standard 4-20 mA signal. DeltaV SIS has not only the capability to pass on the field device diagnostics information to an Asset Management System (AMS) or the BPCS via Modbus or OPC but to bring field diagnostics into the logic solver. For example, DeltaV SIS can use the HART diagnostics to determine if a field device is unhealthy and remove the device from voting if desired. It is up to the end user to determine if these status signals should be used for voting degradation or not.

The DeltaV SIS logic solver can also generate HART commands to initiate a partial stroke test in a digital valve controller. The operators can initiate partial stroke tests manually from a third-party HMI by writing to the PST\_START parameter via Modbus or OPC. Partial stroke tests can also occur automatically based on a specified test interval. The results from these tests are captured and integrated with the system event history. An alarm can be generated if a partial stroke test fails, alerting maintenance that there is a potential problem with a valve. HART can also retrieve other useful information from digital valve controllers such as the stroke time calculated at the device.

## Local Safety Network (LSN)

The CSLs communicate secure parameter and input data to other CSLs over the LSN. The LSN is a fully redundant Ethernet network and must be treated as a dedicated standalone network (not connected to any other network).

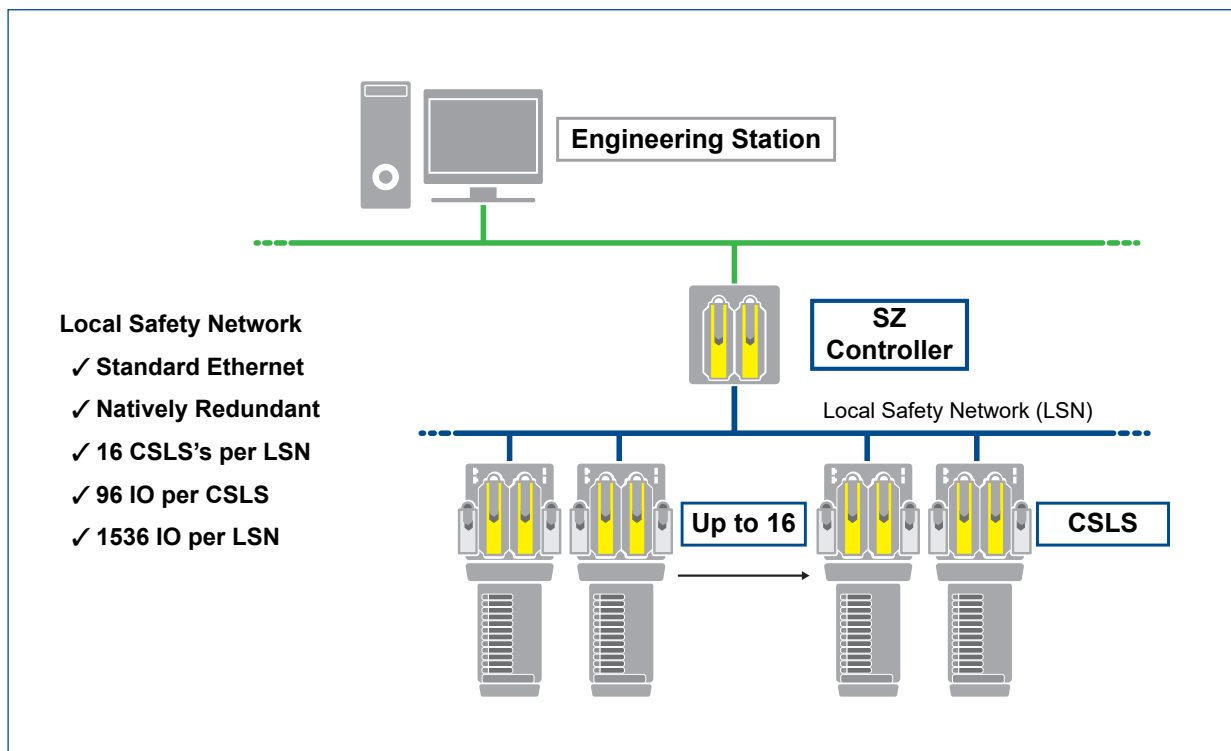

Figure 4 – Local Safety Network

Connection to an engineering station and/or HMI is through the SZ controller. The SZ Controller does not interfere on the secure communication between logic solvers, if for some reason the SZ is disconnected, the safety-rated communication between logic solvers is not affected. For larger systems, multiple Local Safety Networks (LSN) can be integrated using the Local Safety Network Bridge (LSNB) where safety communication is required across LSN's.

## Local Safety Network Bridge (LSNB)

Beginning with DeltaV SIS v13.3, the Global Safety Network (GSN) enables safety rated communication across LSNs while allowing functional segregation on different LSNs. A typical example is separation of F&G, BMS, and ESD applications over separate LSNs while allowing safe and secure communication across all three applications.

A Local Safety Network Bridge (LSNB) can be installed on two or more LSNs to communicate safety rated data over the GSN. For more information about the GSN and LSNB, see the **DeltaV SIS with Local Safety Network Components** product data sheet.

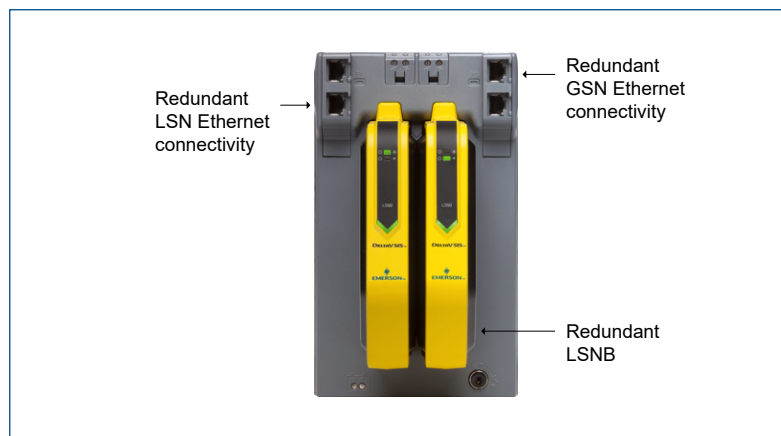

Figure 5 – Local Safety Network Bridge

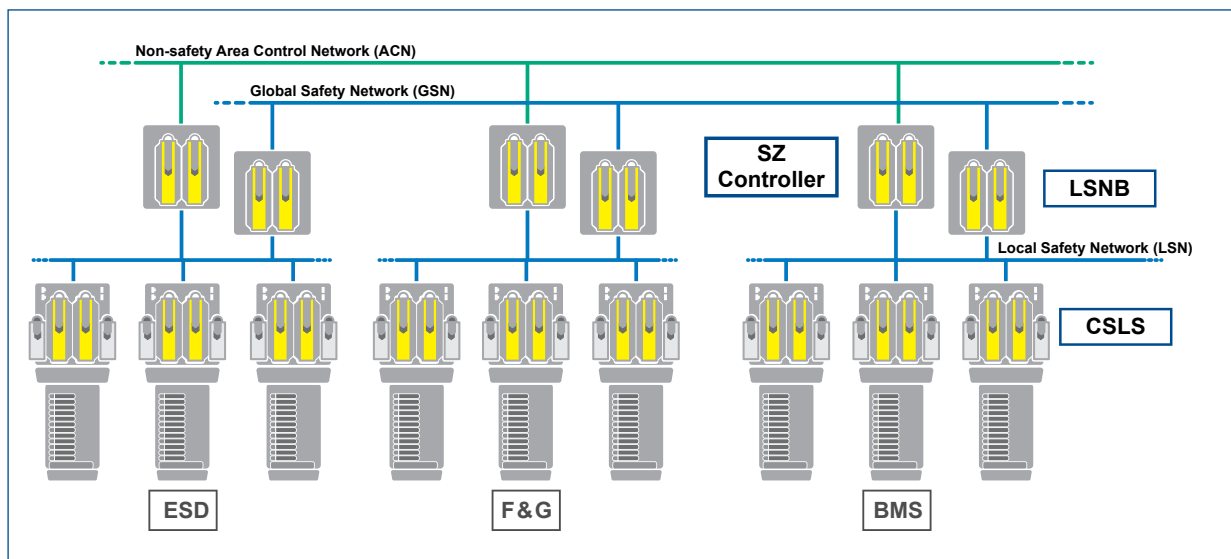

Figure 6 – Global Safety Network

## SZ Controller

The SZ controller is the proxy (or gateway) between the LSN and the BPCS, and it is certified per Achilles Level 2. The SZ controller isolates the safety-critical components (logic solvers and field devices) from non safety-critical components such as the engineering stations or BPCS nodes. The SZ controller carrier provides 4 Ethernet ports. The top two ports connect to the configuration station and BPCS while the bottom two ports connect to the LSN. It does not execute safety logic, its main function is to isolate the LSN from the BPCS and communicate configuration, parameter changes, and module data to the CSLs from the engineering station and BPCS. The SZ controller provides the interface to multiple CSLs on the same LSN. All CSLs under one SZ controller share the same LSN.

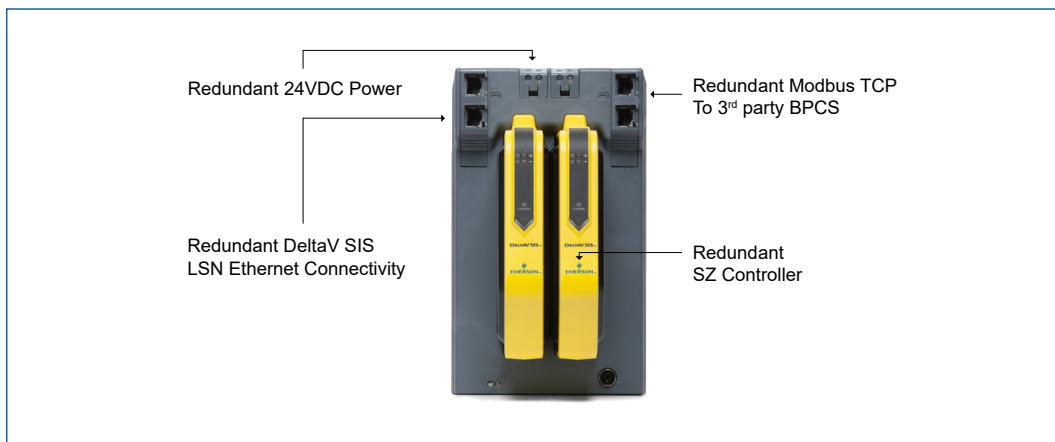

Figure 7 – SZ controller

In Standalone applications, the top Ethernet ports provide native Modbus TCP protocol communication to interface to a third party BPCS. In this case, the SZ controller is a Modbus slave device.

## Engineering Station

DeltaV SIS is configured via an engineering station that comes with a complete set of tools including user management, engineering, diagnostic, sequence of events (SOE) and process safety historian for up to 250 process variables. A comprehensive Management of Change package can also be added. From IEC 61131-3 graphical control strategy configuration to alarms and events collection, the engineering station has it all. For larger standalone applications, the SOE, Historian and Manage of Change database can reside on different workstations.

Some of the applications included on the engineering station are:

- **Control Studio Configuration software suite.** Makes it easy to create safety logic and system graphics.
- **Control Studio on-line.** Graphically monitor and troubleshoot running safety logic.
- **DeltaV Live.** HTML5 based HMI to create high performance operator graphics, hierarchical navigation, trends and alarms offered in standard operating layout.
- **Operate.** HMI to create high performance operator graphics, trends and alarms offered in standard operating layout.
- **Diagnostics.** Facilitates checking the overall health of the system.
- **Event chronicle.** Captures process, system and user alarms and events and stores them in a Microsoft SQL Server database.
- **Continuous Historian.** Captures up to 250 parameters with their status and stores them for future analysis. For larger historian needs an separate application station can be added.

- **Historical View suite.** Monitor your plants continuous and even data – historical and in real time.
- **Device Commissioner.** Simplifies the commissioning of HART field devices

To enhance your engineering station, the following options may be added:

## Version Control and Audit Trail (VCAT)

This powerful Management Of Change tool has Check-in/Check-out, Electronic Signature, both Graphical and Text configuration version comparison, and many other capabilities that helps keeping track on changes and help the compliance with the standards. Refer to the **DeltaV SIS Configuration Audit Trail** product data sheet for more information.

## AMS Device Manager

Provides the engineering interface to device calibration and configuration software for HART field devices.

AMS SNAP-ON Product Options. Choose from a variety of AMS configuration options. Refer to [www.assetweb.com](http://www.assetweb.com) for the list of SNAP-ON product options.

## Engineering Station Hardware

For the engineering station hardware, you can choose from the **DeltaV Workstation Hardware PDS**.

For standalone applications not requiring a permanent engineering station, it is common that customers require laptops. The preferred option is Dell Latitude 14' Rugged 5420 (consult the DeltaV Workstation Hardware PDS for details). As alternative Emerson has approved the Panasonic Toughbook® CF-31 for configuration management, diagnostics and retrieval of event records. The Panasonic CF-31 is a rugged full-size laptop with a 13.1" color touchscreen, QWERTY keyboard and comes optionally equipped with Wi-Fi, cellular, and Bluetooth® radios, GPS, integrated webcam, fingerprint scanner, and is available with a Class 1 Div 2 certification. Since the laptop is not intended to be connected all the time, only one network adapter is needed for communication to the primary network (non-safety ACN). The minimum requirements for the laptop are: Windows 7 64-bit, 4 GB RAM, and 452 GB hard drive.

## Alarms and Events

Within DeltaV SIS, the Event Chronicle application collects alarms and events and stores them on the engineering station or separate application station if desired, allowing for easy retrieval and analysis.

A standard set of events are automatically generated without special configuration or programming required. For example, I/O failures, trip limits, first outs, and other similar events are automatically time stamped and recorded in Event Chronicle. When a process variable exceeds a trip limit, DeltaV SIS records the event along with the analog value and the trip condition.

Run time values can be transferred via either Modbus TCP or OPC interfaces in order to create alarms at the BPCS.

## Sequence of Events Capability

Events are time stamped with a resolution of 1 ms, and they are recorded in the Event Chronicle in the sequence that they occur. In general, when there is a plant event that triggers an emergency shutdown from the SIS, one input will exceed a trip limit on one scan and this will cause outputs to trip and more inputs will then change state. Sequence of Events Recording has been used to find that first input that caused the trip by looking at all of the inputs in the plant. With the DeltaV SIS system, the operator simply filters the Event Chronicle for first out trips, and the first-out is clearly visible.

Determining the sequence of events requires tight time synchronization among the DeltaV SIS nodes. The SZ controller supports Network Time Protocol (NTP) which is a standard communication protocol that allows computers to synchronize with a timeserver across a network. DeltaV SIS supports master and backup timeservers as a standard feature. By default, the master timeserver is the engineering station. An external NTP server that receives its time directly from some standardize reference time source (GPS for example) can also be used.



All DeltaV SIS devices are synchronized with the master timeserver, by default the engineering station.

The CSLS's ability to capture events does not depend on the communication to the engineering station.

## Event Buffering Capabilities

Each CSLS has the capability of buffering 500 module events, 500 first out events, 50 device events and 100 LS-CHARM events. These buffered events will be transferred to the event chronicle once the connection to the engineering workstation is resumed.

## Non-safety critical I/O and control logic:

The SZ controller can also execute non-safety control logic allowing the integration of non-safety loops without requiring a separate BPCS. For example, in a boiler application, the SZ controller can execute the boiler control logic while DeltaV SIS executes the BMS safety logic. Non-safety I/O is connected to CHARMS I/O Cards (CIOC) which communicates I/O data to the SZ controller through the non-safety area control network. Each SZ controller can assign up to four CIOCs, as well as retrieve process variable from the CSLSs at a scan of 100ms. Wireless HART devices can be integrated via the Wireless I/O Card (WIOC). Up to four WIOC can be assigned to an SZ controller. Any combination of CIOC and WIOC is allowed not exceeding 4 I/O nodes.

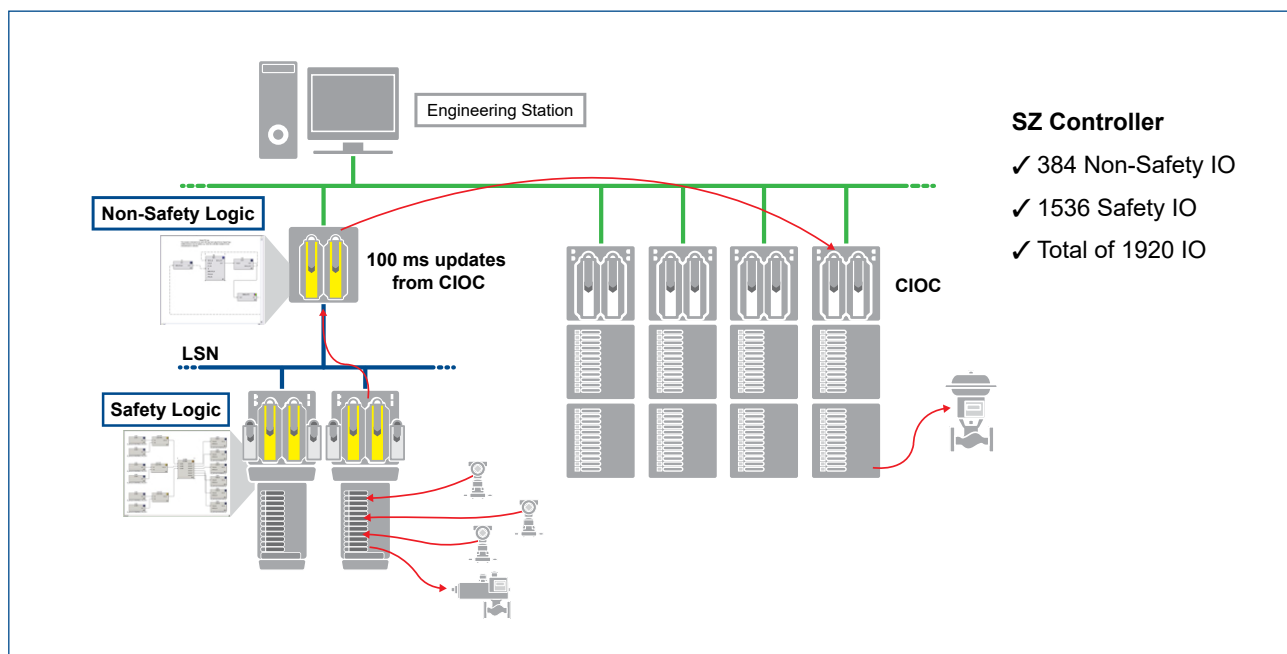

Figure 8 – Non-safety critical control

## Licensing Options

There are two main options for DeltaV SIS as standalone system. One option is using DeltaV base licenses and the other options is using PK controller standalone licenses.

## Base Licenses

Before you can download your safety logic configuration to the DeltaV SIS system, you must attach the system identifier to the engineering workstation, load your licenses on the engineering workstation from a license disk, and assign licenses to the workstations and SZ controllers. The system identifier, shipped in the License Pack, is a connector that plugs into a USB port on the engineering workstation. A DeltaV SIS configuration license is required on each system.

## PK Controller Licenses

The Emerson PK Controller provides a control and safety solution designed to operate in a standalone fashion. The PK controller and associated logic solvers are configured using the PK Controller Engineering Software but it does not require a connection to the PK Controller Engineering Software to run in a standalone fashion. The on-board SD-card in the PK controller stores and backup all configuration and HMI files, enabling a laptop to retrieve those files. A standalone PK Controller can be deployed with one operator station (Panel HMI or workstation PC) to serve local HMI needs. The PK controller integrates with DeltaV SIS with Electronic Marshalling as described in figure 9.

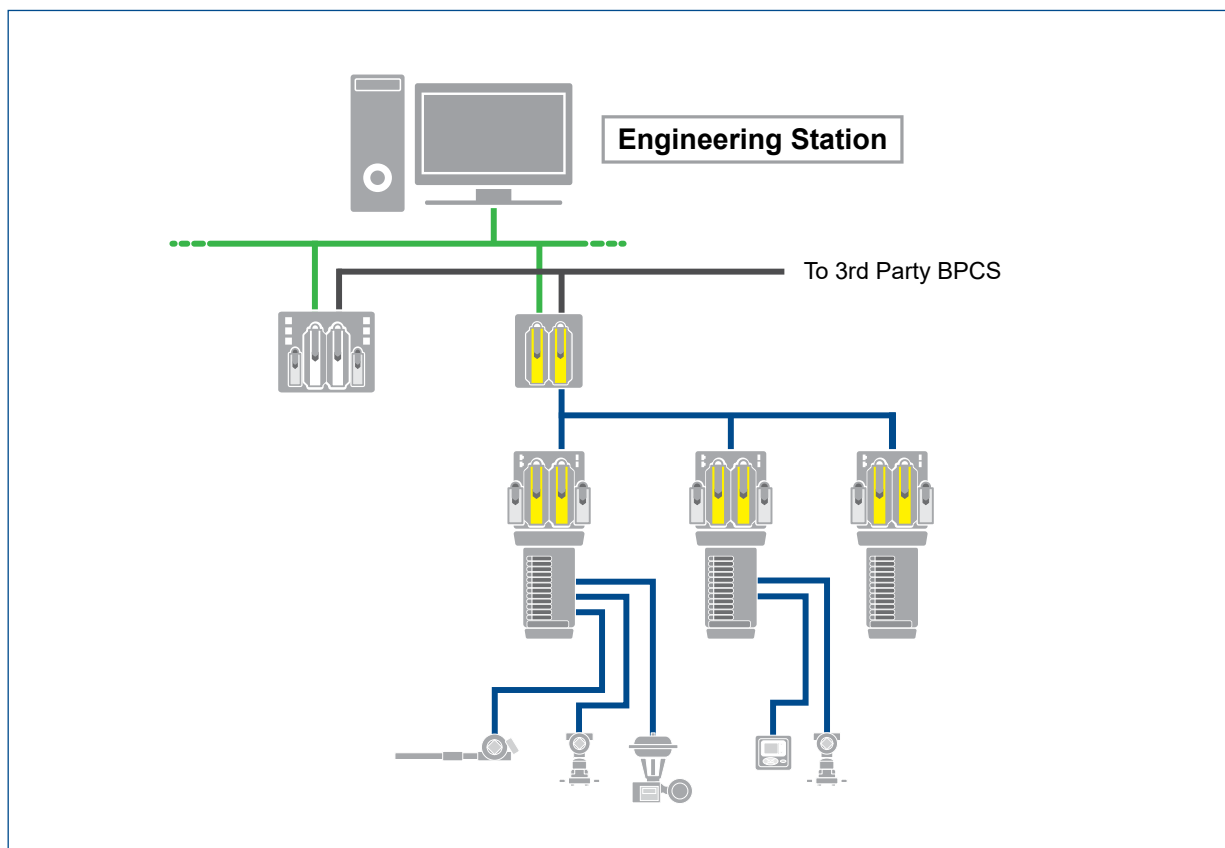

Figure 9 – DeltaV SIS with standalone PK controller

The PK controller can be used for applications in a wide variety of sizes, from 100 to 1500 DSTs. The PK size will define the overall size of the PK standalone system. For example, a PK100 will limit the DST count for this PK Standalone system to 100 DST, and this considers DSTs consumed by the PK itself and the DST associated with the SZ and LSN. The PK controller support multiple communication protocols such as OPC UA server, EtherNet/IP, and Modbus TCP master and slave. For more information about the PK controller consult the DeltaV PK controller PDS.

## Support Services

All DeltaV SIS products are fully supported under the Emerson Guardian and Foundation Support programs. DeltaV SIS is supported for both integrated and standalone architectures. Emerson can provide consulting services to help on the integration of DeltaV SIS with a 3rd party BPCS.

Emerson provides limited support for the Panasonic laptop. Emerson will provide implementation guidelines, but the customer is responsible for configuration and implementation of DeltaV SIS in the Panasonic laptop. We will provide a reasonable effort to support DeltaV SIS running in this laptop; however, should we suspect that laptop implementation is causing an incident; the customer will need to either purchase Emerson support services to help troubleshoot and resolve the incident, or contact the appropriate Panasonic support provider.

## Interfacing to a BPCS

DeltaV SIS with Electronic Marshalling can be interfaced with any BPCS in different ways using common standards such as Modbus TCP or OPC. For systems with one SZ controller, the preferred method is the Modbus TCP interface on the SZ controller. An alternative method for systems with one SZ controller is the use of PK controller. The PK controller enables more connectivity options such as OPC UA server and EtherNet/IP. For systems with multiple SZ controller, it is preferable to use the Ethernet I/O card (EIOC) or OPC interfaces on application stations. The following subsections explain the different methods to interface DeltaV SIS.

### Modbus TCP Interface (SZ Controller)

Modbus TCP is natively available on the SZ controller and functions as a Modbus slave device communicating to a Modbus master. The SZ controller supports both simplex and redundant Modbus (v13.3 is required for redundant Modbus). The IP address of the DeltaV SIS SZ controller's Modbus TCP ports are configured through the Modbus Port properties. A Modbus firewall might be required by the third-party system.

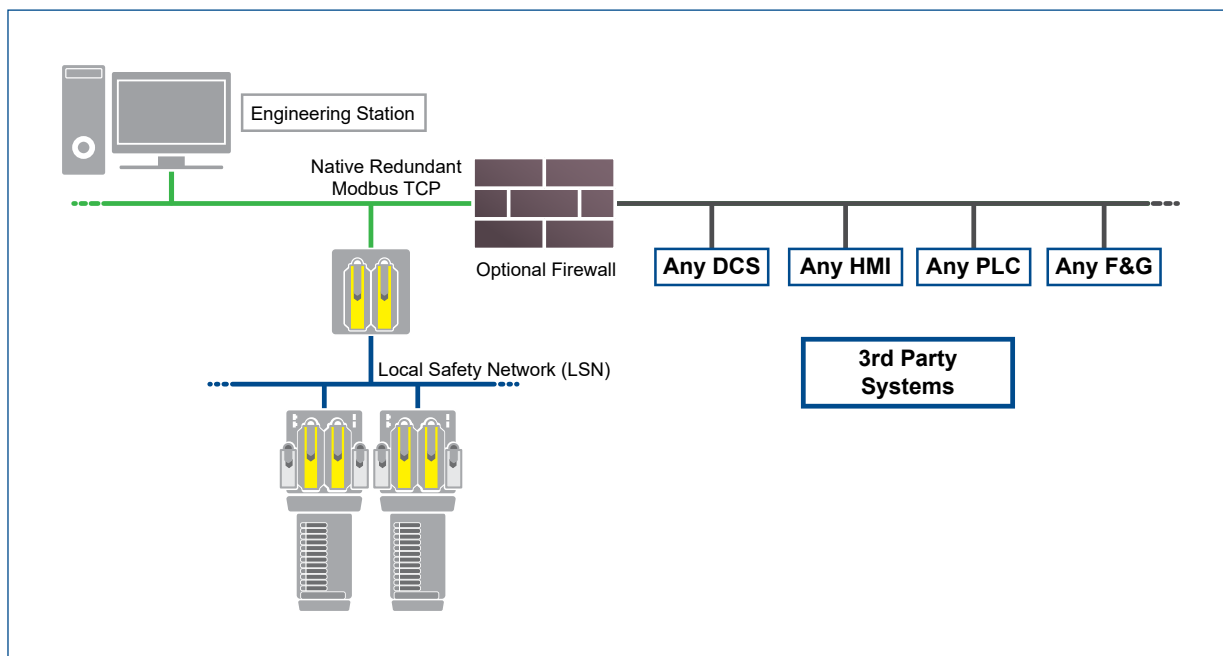

Figure 10 – Modbus TCP Interfaced Safety Instrumented System

Data from DeltaV SIS must be mapped to Modbus port registers. Only function block and module parameters can be mapped. You can map parameters to Modbus port registers from the Register mapping and Map Register dialogs. However, because of the possible large number of parameters to map, using Bulk Edit and Excel is easier for initial configuration. There is one mapping table for each SZ controller.

Mapping of SIF\_ALERTS parameters makes it very easy to send information to the BPCS about a particular SIF such as active bypasses, active startup overrides, trip consensus, pre-trip consensus, forces, and output blocks in an off state. All this information is available in a single parameter which makes connecting DeltaV SIS to a 3rd party BPCS easy. In a similar way, the SIF\_ERROR parameter allows the user to send error information such as bad status on input block, bad status on output block or last partial stroke test failed.

HART diagnostics information can be transferred by creating a non-SIS module in the SZ Controller to read the HART device information and then mapping the non-SIS module parameters to Modbus registers.

Direct writes into the CSLS are not allowed. Modbus registers are passed from the SZ Controller to the CSLS via a non-secure parameter. The main usages for writes into a safety system from a third-party BPCS are for resets and input bypasses.

The following function codes are supported from the Modbus Interface on the SZ controller.

Function commands	Description
1	Read multiple coils (1 bit per coil)
2	Read multiple input statuses (1 bit per status)
3	Read holding registers
4	Read multiple input registers (2 bytes per register)
5	Write single coil (0x0000 = OFF, 0xFF00 = ON)
15	Write multiple coils (1 bit per coil)

## Interfaces on PK Controller

The PK controller supports both Modbus master and slave interfaces as well as EtherNet/IP.

The OPC UA server in the PK controller provides native server implementation of a Data Access profile compliant with OPC UA version 1.02.

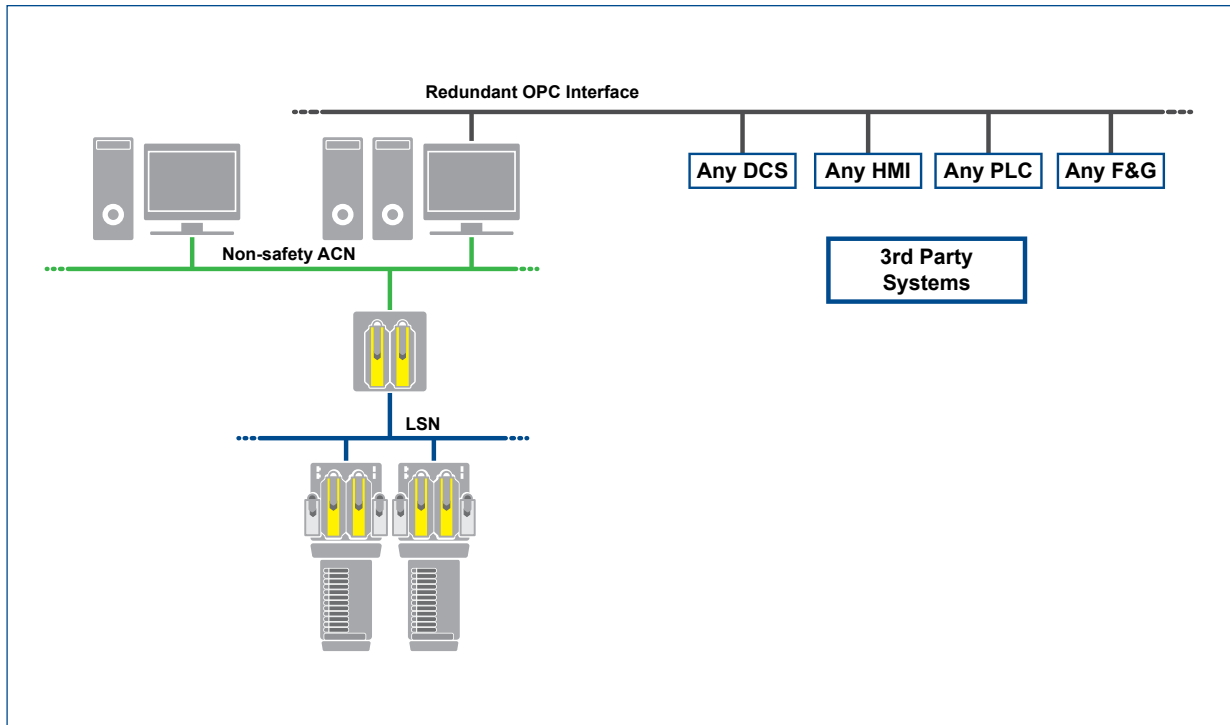

Figure 11 – OPC Interfaced Safety Instrumented System

### OPC DA Interface (Application Station)

The redundant OPC DA server enabled by the Application Station, gives you the ability to integrate DeltaV SIS with a third-party BPCS or HMI up to 30,000 values each second. Optionally, an OPC Events Server can be added to allow integration of real-time alarms and/or events from DeltaV SIS with any OPC Alarms & Events compatible client application.

The redundant OPC server prevents a single point of failure in the communications with the third-party BPCS. When the active OPC server fails, the standby OPC server automatically takes over, providing reliable data transfer without user intervention. For more information about Application Stations, see the Application Station Software Suite and OPC Data Access Server Redundancy product data sheets.

In the case of interfacing with another OPC server, OPC Mirror is an OPC Data Access compliant software application that enables two or more OPC Data Access servers to communicate with each other. The OPC standard is based on client-server architecture; OPC clients send and receive data from OPC servers. OPC Mirror enables OPC server to server communication, acting as bi-directional client to OPC servers. For increased availability of your OPC data, OPC Mirror has an option for redundant operation. Two instances of OPC mirror work together on two Application Stations in active and standby roles. Failure of the active OPC mirror or any connected OPC server causes automatic failover to the standby OPC Mirror, ensuring seamless data transfer. For more information about OPC Mirror, see the OPC Mirror and OPC Mirror Redundancy product data sheets.

### OPC UA Interface (Application Station and EIOC)

Starting version 14, DeltaV SIS can be interfaced via OPC UA. DeltaV OPC UA servers are provided in both the Application Station and the ProfessionalPLUS station. This single interface supports real-time process data (DA), real-time alarm and event data (A&E), and historical data (HDA). DeltaV OPC UA clients are provided in the Ethernet I/O card (EIOC), Application station and ProfessionalPLUS enabling connectivity to external OPC UA servers without the use of OPC Mirror. For information, see the DeltaV OPC UA Servers and Clients product data sheet.

## Configured to Order (CTO) Cabinets and Field Enclosures

The DeltaV SIS Configure-To-Order (CTO) CHARMs Smart Logic Solver (CSLS) Cabinets and Field Enclosures provide an off-the-shelf solution for faster project execution and reduced installation costs. CTO CSLS Cabinets are factory tested and ready for installation in technical rooms and the CTO field enclosure is mount out in the process area. Electronic Marshalling eliminates traditional I/O design tasks and allows field wiring to start long before safety strategies are finalized. For more information, refer to the **CTO CSLS CHARM Cabinets** and **CTO CSLS CHARM Field Enclosure** product data sheet.

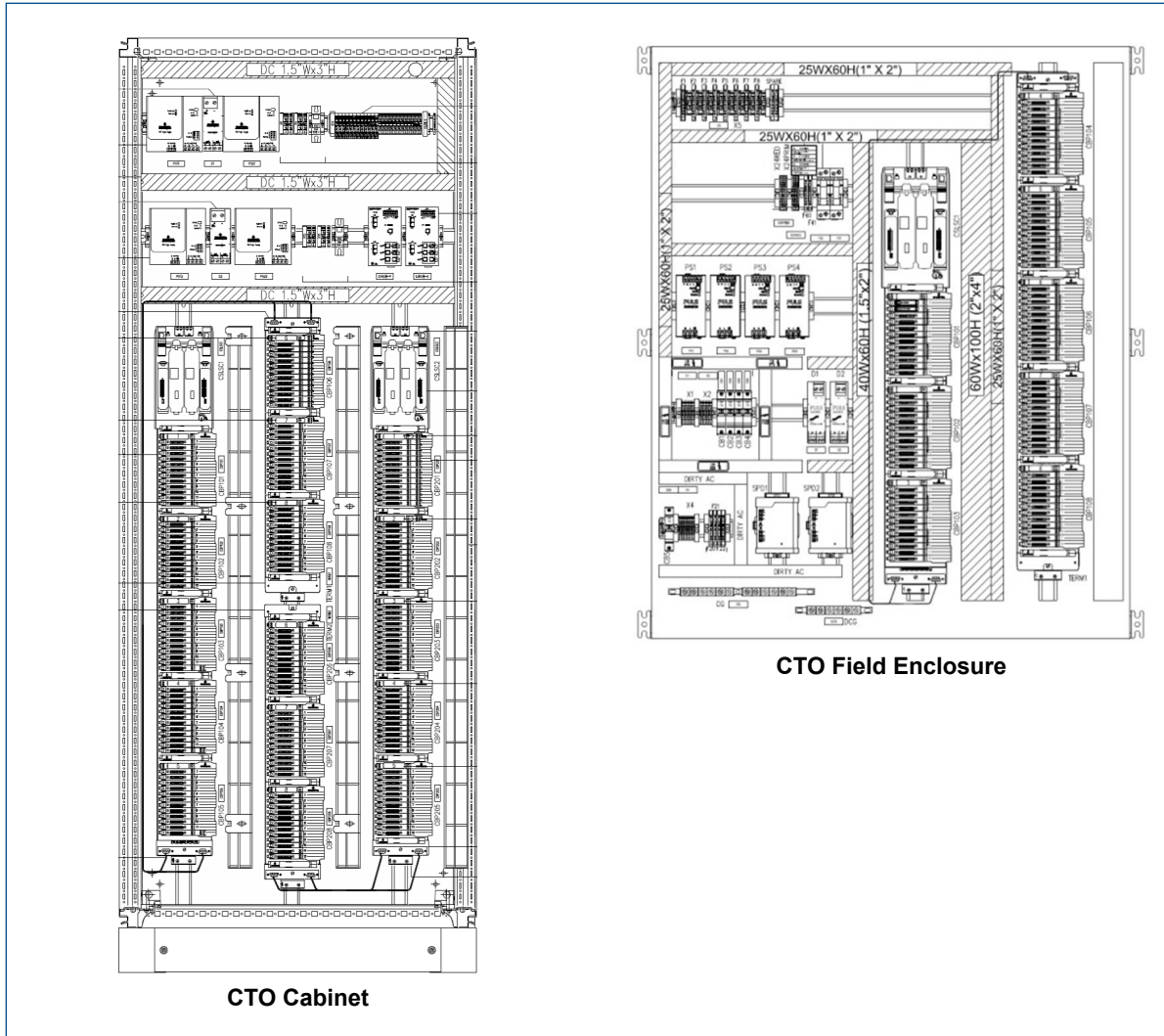

Figure 12 – CTO Options

## Cyber security Features

There are multiple built-in security features available within DeltaV SIS to protect against security threats including:

- Network segmentation to isolate safety critical components from components not required for execution of the safety function
- Multiple layers of protection against unauthorized access, including enforcing of physical presence to prevent remote attacks
- Automatic removal of maintenance bypasses to prevent both inadvertent or intentional defeat of safety logic.

For more information about the DeltaV security features, consult the **DeltaV SIS and Cybersecurity** whitepaper.

## Summary

In summary, when choosing DeltaV SIS as your Safety Instrumented System platform, you can take advantage of a modern safety system with a modular architecture, increased configuration flexibility, higher availability, extended system life, and optimal use of HART communication.

Emerson is committed to providing a safety instrumented solution which is easy to use and provides the same safety performance and reliability that our customers have come to expect.

**Emerson**  
**North America, Latin America:**  
☎ +1 800 833 8314 or  
☎ +1 512 832 3774

**Asia Pacific:**  
☎ +65 6777 8211

**Europe, Middle East:**  
☎ +41 41 768 6111

🌐 [www.emerson.com/deltavsis](http://www.emerson.com/deltavsis)

The Emerson logo is a trademark and service mark of Emerson Electric Co. The DeltaV logo is a mark of one of the Emerson family of companies. All other marks are the property of their respective owners.

The contents of this publication are presented for informational purposes only, and while diligent efforts were made to ensure their accuracy, they are not to be construed as warranties or guarantees, express or implied, regarding the products or services described herein or their use or applicability. All sales are governed by our terms and conditions, which are available on request. We reserve the right to modify or improve the designs or specifications of our products at any time without notice.

