

Rosemount™ 8712EM Transmitter with FOUNDATION™ Fieldbus

Includes support for 8750W



1 Safety

⚠ WARNING

- Failure to follow these installation guidelines could result in serious injury or death.
- Installation and servicing instructions are for use by qualified personnel only. Do not perform any servicing other than that contained in the operating instructions, unless qualified.
- Rosemount Magnetic Flowmeters ordered with non-standard paint options or non-metallic labels may be subject to electrostatic discharge. To avoid electrostatic charge build-up, do not rub the flowmeter with a dry cloth or clean with solvents.
- Verify that the operating environment of the sensor and transmitter is consistent with the appropriate Agency Approval.
- If installed in an explosive atmosphere, verify that the device certification and installation techniques are suitable for that particular environment.
- To prevent ignition of flammable or combustible atmosphere, disconnect power before servicing circuits.
- Explosion hazard—Do not disconnect equipment when a flammable or combustible atmosphere is present.
- Do not connect a Rosemount Transmitter to a non-Rosemount sensor when installed in an “Ex” environment, explosive atmosphere, hazardous area, or classified area.
- Follow national, local, and plant standards to properly earth ground the transmitter and sensor. The earth ground must be separate from the process reference ground.

⚠ CAUTION

- In cases where high voltage/high current are present near the meter installation, ensure proper protection methods are followed to prevent stray voltage/current from passing through the meter. Failure to adequately protect the meter could result in damage to the transmitter and lead to meter failure.
- Completely remove all electrical connections from both sensor and transmitter prior to welding on the pipe. For maximum protection of the sensor, consider removing it from the pipeline.

2 Introduction

This document provides basic installation guidelines for the Rosemount 8712EM wall-mount transmitter.

- For sensor installation refer to the *Rosemount™ 8700 Magnetic Flow Meter Sensor Quick Installation Guide*

All user documentation can be found at www.emerson.com. For more contact information see [Emerson Flow customer service](#).

2.1 Return policy

Emerson procedures must be followed when returning equipment. These procedures ensure legal compliance with government transportation agencies and help provide a safe working environment for Emerson employees. Failure to follow Emerson procedures will result in your equipment being refused delivery.

2.2 Emerson Flow customer service

Email:

- Worldwide: flow.support@emerson.com
- Asia-Pacific: APflow.support@emerson.com

Telephone:

North and South America		Europe and Middle East		Asia Pacific	
United States	800 522 6277	U.K.	0870 240 1978	Australia	800 158 727
Canada	+1 303 527 5200	The Netherlands	+31 (0) 704 136 666	New Zealand	099 128 804
Mexico	+41 (0) 41 7686 111	France	0800 917 901	India	800 440 1468
Argentina	+54 11 4837 7000	Germany	0800 182 5347	Pakistan	888 550 2682
Brazil	+55 15 3413 8000	Italy	8008 77334	China	+86 21 2892 9000
Venezuela	+58 26 1731 3446	Central & Eastern	+41 (0) 41 7686 111	Japan	+81 3 5769 6803
		Russia/CIS	+7 495 981 9811	South Korea	+82 2 3438 4600
		Egypt	0800 000 0015	Singapore	+65 6 777 8211
		Oman	800 70101	Thailand	001 800 441 6426
		Qatar	431 0044	Malaysia	800 814 008
		Kuwait	663 299 01		
		South Africa	800 991 390		
		Saudi Arabia	800 844 9564		
		UAE	800 0444 0684		

3 Pre-Installation

Before installing the transmitter, there are several pre-installation steps that should be completed to make the installation process easier:

- Set the hardware switches if necessary
- Consider mechanical, electrical, and environmental requirements

Note

Refer to the product reference manual for more detailed requirements.

Hardware switches

The electronics board is equipped with two user-selectable hardware switches. These switches set the Simulate Enable and Transmitter Security. The standard configuration for these switches when shipped from the factory are as follows:

Table 3-1: Hardware switch default settings

Setting	Factory configuration
Simulate enable	Off
Transmitter security	Off

In most cases, it is not necessary to change the setting of the hardware switches. If the switch settings need to be changed, refer to the product reference manual.

Be sure to identify any additional options and configurations that apply to the installation. Keep a list of these options for consideration during the installation and configuration procedures.

Mechanical considerations

The mounting site for the transmitter should provide enough room for secure mounting, easy access to conduit entries, full opening of the transmitter covers, and easy readability of the Display screen (if equipped).

Figure 3-1: Rosemount 8712EM Dimensional Drawing

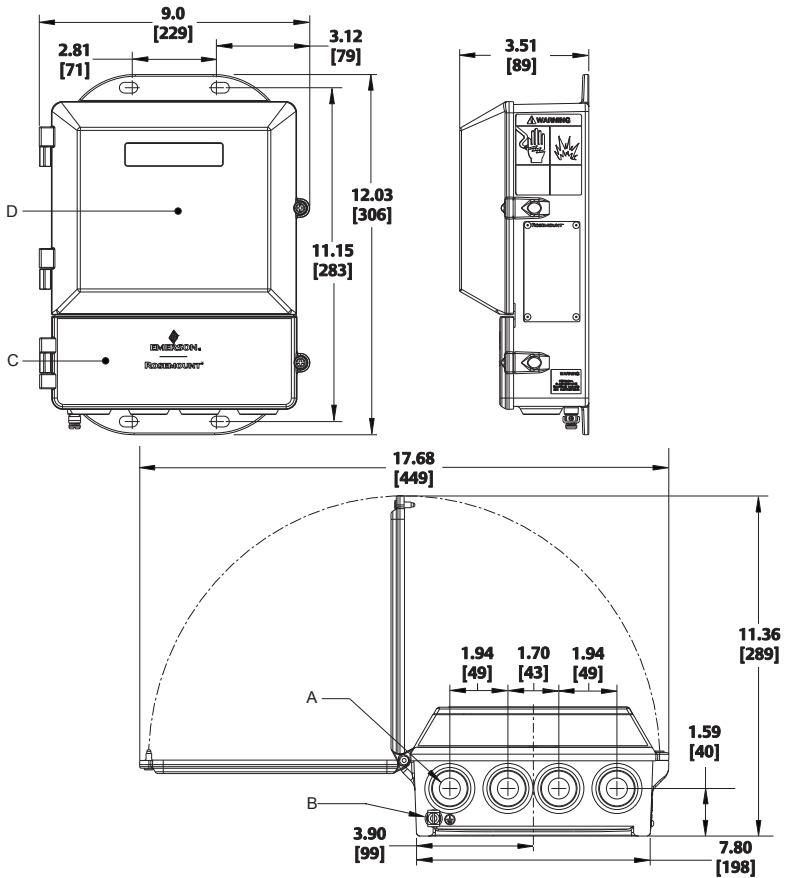

- A. Conduit entry, 1/2-14 NPT (4 places)
- B. Ground lug
- C. Lower cover opens for electrical connections
- D. Standard electronics cover

Note

Dimensions are in inches [Millimeters]

Electrical considerations

Before making any electrical connections to the transmitter, consider national, local, and plant electrical installation requirements. Be sure to have the proper power supply, conduit, and other accessories necessary to comply with these standards.

The transmitter requires external power. Ensure access to a suitable power source.

Table 3-2: Electrical data

Rosemount 8712E flow transmitter with FOUNDATION fieldbus	
Power input	AC power: 90–250VAC, 0.45A, 40VA
	Standard DC power: 12–42VDC, 1.2A, 15W
Fieldbus	Fieldbus segment requires a separate 9VDC to 32VDC power supply with a power conditioner to decouple the power supply output from the fieldbus wiring segment.

Environmental considerations

To ensure maximum transmitter life, avoid extreme temperatures and excessive vibration. Typical problem areas include the following:

- Tropical or desert installations in direct sunlight
- Outdoor installations in arctic climates

Remote mounted transmitters may be installed in the control room to protect the electronics from the harsh environment and to provide easy access for configuration or service.

4 Mounting

Wall mount transmitters are shipped with mounting hardware for use on a 2-in. pipe or flat surface.

Figure 4-1: Mounting bracket

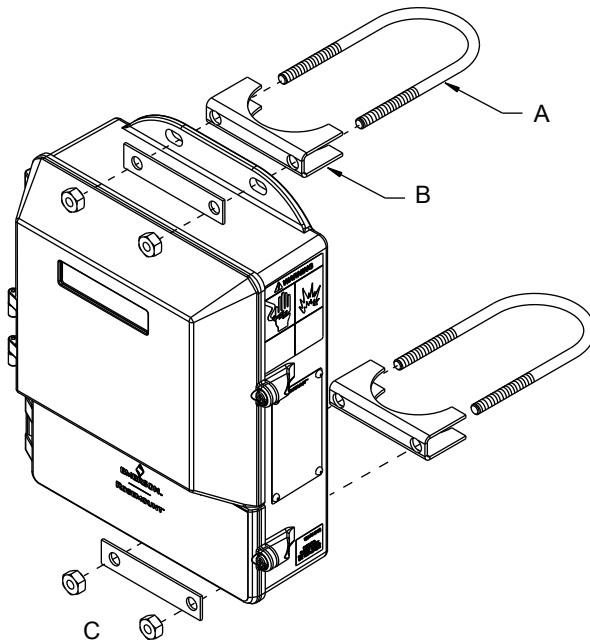

- A. U-bolt
- B. Saddle clamp
- C. Fasteners

4.1 Pipe mounting

1. Attach the saddle clamp to the pipe using the U-bolt mounting hardware.
2. Attach the transmitter to the saddle clamp assembly with appropriate fasteners.

4.2 Surface mounting

Attach the transmitter to the mounting location using customer supplied mounting screws. The installation of the transmitter shall be rated for four (4) times the weight of the transmitter or 44lbs (20kgs).

5 Wiring

5.1 Conduit entries and connections

Transmitter conduit entries ports are ½"-14NPT as standard, M20 conduit connections will use an adapter. Conduit connections should be made in accordance with national, local, and plant electrical codes. Unused conduit entries should be sealed with the appropriate certified plugs. The plastic shipping plugs do not provide ingress protection.

5.2 Conduit requirements

- For installations with an intrinsically safe electrode circuit, a separate conduit for the coil cable and the electrode cable may be required. Refer to the product reference manual.
- For installations with non-intrinsically safe electrode circuit, or when using the combination cable, a single dedicated conduit run for the coil drive and electrode cable between the sensor and the remote transmitter may be acceptable. Removal of the barriers for intrinsic safety isolation is permitted for non-intrinsically safe electrode installations.
- Bundled cables from other equipment in a single conduit are likely to create interference and noise in the system. See [Figure 5-1](#).
- Electrode cables should not be run together in the same cable tray with power cables.
- Output cables should not be run together with power cables.
- Select conduit size appropriate to feed cables through to the flowmeter.

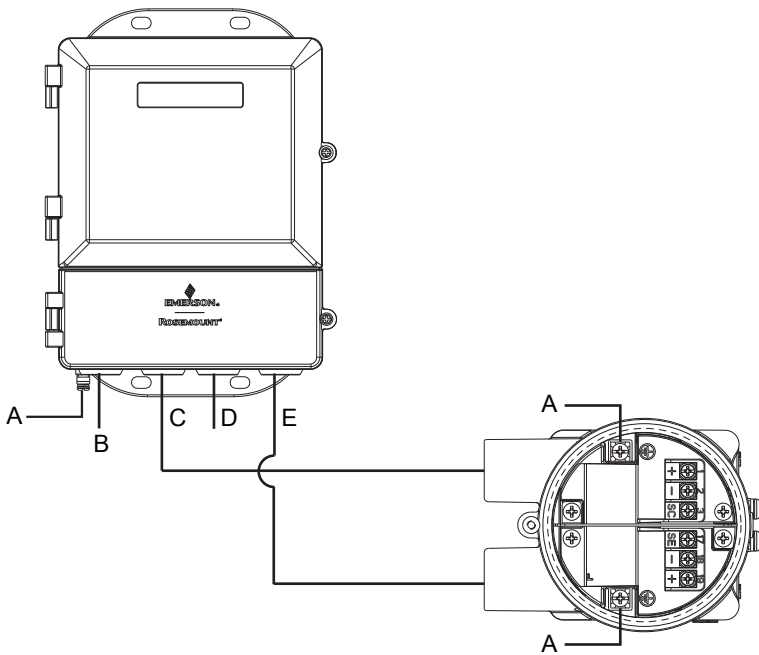
Figure 5-1: Best practice conduit preparation

- A. Safety ground
- B. Power
- C. Coil
- D. Output
- E. Electrode

5.3 Sensor to transmitter wiring

Cable kits are available as individual component cables or as a combination coil/electrode cable. Remote cables can be ordered directly using the kit numbers shown in [Table 5-1](#), [Table 5-2](#), and [Table 5-3](#). Equivalent Alpha cable part numbers are also provided as an alternative. To order cable, specify length as quantity desired. Equal length of component cables is required.

Examples:

- 25 feet = Qty (25) 08732-0065-0001
- 25 meters = Qty (25) 08732-0065-0002

Table 5-1: Component cable kits - standard temperature (-20°C to 75°C)

Cable kit #	Description	Individual cable	Alpha p/n
08732-0065-0001 (feet)	Kit, component cables, Std temp (includes Coil and Electrode)	Coil Electrode	2442C 2413C
08732-0065-0002 (meters)	Kit, component cables, Std temp (includes Coil and Electrode)	Coil Electrode	2442C 2413C
08732-0065-0003 (feet)	Kit, component cables, Std temp (includes Coil and I.S. Electrode)	Coil Intrinsically Safe Blue Electrode	2442C Not available
08732-0065-0004 (meters)	Kit, component cables, Std temp (includes Coil and I.S. Electrode)	Coil Intrinsically Safe Blue Electrode	2442C Not available

Table 5-2: Component cable kits - extended temperature (-50°C to 125°C)

Cable kit #	Description	Individual cable	Alpha p/n
08732-0065-1001 (feet)	Kit, Component Cables, Ext Temp. (includes Coil and Electrode)	Coil Electrode	Not available Not available
08732-0065-1002 (meters)	Kit, Component Cables, Ext Temp. (includes Coil and Electrode)	Coil Electrode	Not available Not available
08732-0065-1003 (feet)	Kit, Component Cables, Ext Temp. (includes Coil and I.S. Electrode)	Coil Intrinsically Safe Blue Electrode	Not available Not available
08732-0065-1004 (meters)	Kit, Component Cables, Ext Temp. (includes Coil and I.S. Electrode)	Coil Intrinsically Safe Blue Electrode	Not available Not available

Table 5-3: Combination cable kits - coil and electrode cable (-20°C to 80°C)

Cable kit #	Description
08732-0065-2001 (feet)	Kit, Combination Cable, Standard
08732-0065-2002 (meters)	

Table 5-3: Combination cable kits - coil and electrode cable (-20°C to 80°C) (continued)

Cable kit #	Description
08732-0065-3001 (feet)	Kit, Combination Cable, Submersible (80°C dry/60°C Wet) (33ft Continuous)
08732-0065-3002 (meters)	

Cable requirements

Shielded twisted pairs or triads must be used. For installations using the individual coil drive and electrode cable, see [Figure 5-2](#). Cable lengths should be limited to less than 500 feet (152 m). Consult factory for length between 500–1000 feet (152–304 m). Equal length cable is required for each. For installations using the combination coil drive/electrode cable, see [Figure 5-3](#). Combination cable lengths should be limited to less than 330 feet (100 m).

Figure 5-2: Individual component cables

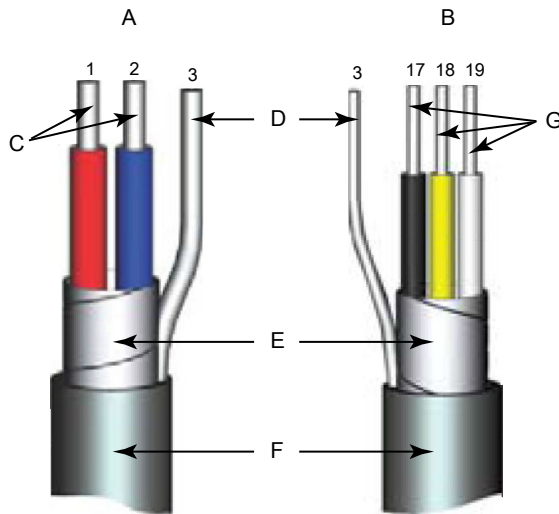

- A. Coil drive
- B. Electrode
- C. Twisted, stranded, insulated 14 AWG conductors
- D. Drain
- E. Overlapping foil shield
- F. Outer jacket
- G. Twisted, stranded, insulated 20 AWG conductors

- 1 = Red
- 2 = Blue
- 3 = Drain
- 17 = Black
- 18 = Yellow
- 19 = White

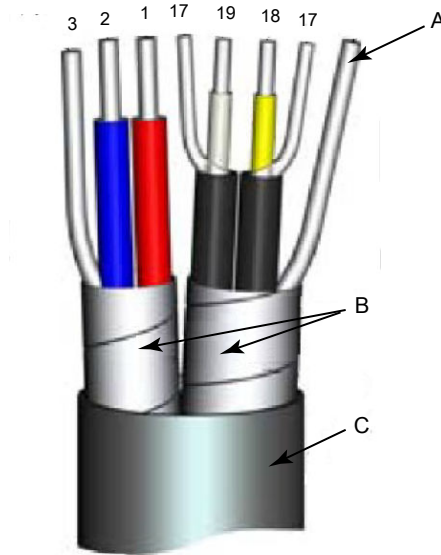
Figure 5-3: Combination coil and electrode cable

- A. *Electrode shield drain*
- B. *Overlapping foil shield*
- C. *Outer jacket*

- 1 = Red
- 2 = Blue
- 3 = Drain
- 17 = Reference
- 18 = Yellow
- 19 = White

Cable preparation

Prepare the ends of the coil drive and electrode cables as shown in [Figure 5-4](#). Remove only enough insulation so that the exposed conductor fits completely under the terminal connection. Best practice is to limit the unshielded length (D) of each conductor to less than one inch. Excessive removal of insulation may result in an unwanted electrical short to the transmitter housing or other terminal connections. Excessive unshielded length, or failure to connect cable shields properly, may also expose the unit to electrical noise, resulting in an unstable meter reading.

Figure 5-4: Cable ends

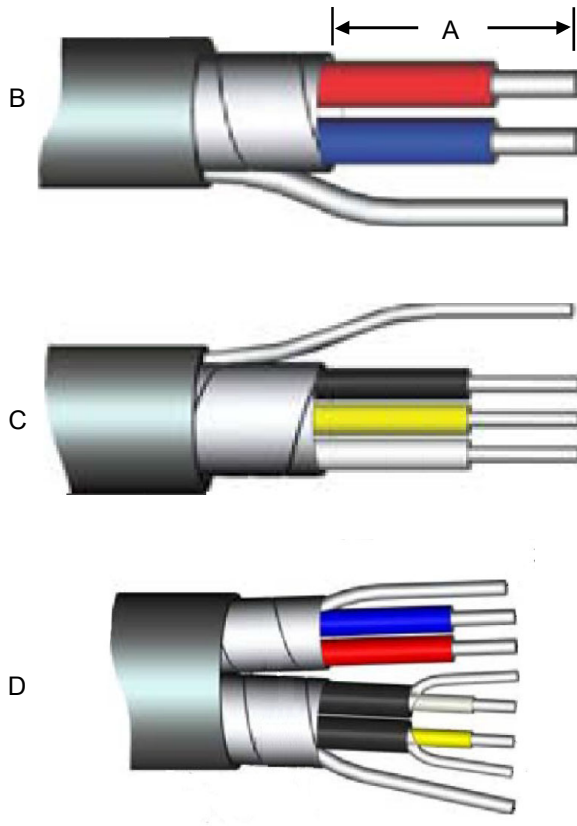

- A. Unshielded length
- B. Coil
- C. Electrode
- D. Combination

⚠ WARNING

Shock hazard! Potential shock hazard across remote junction box terminals 1 and 2 (40V).

⚠ WARNING

Explosion hazard! Electrodes exposed to process. Use only compatible transmitter and approved installation practices. For process temperatures greater than 284°F (140°C), use a wire rated for 257°F (125°C).

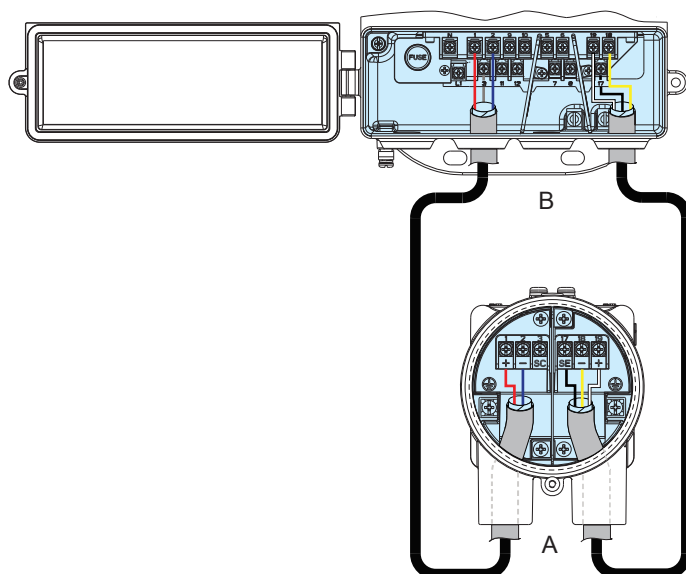

Remote junction box terminal blocks**Figure 5-5: Remote junction box views**

- A. Sensor
B. Transmitter

Table 5-4: Sensor/transmitter wiring

Wire color	Sensor terminal	Transmitter terminal
Red	1	1
Blue	2	2
Coil drain	3 or float	3
Black	17	17
Yellow	18	18
White	19	19

Table 5-4: Sensor/transmitter wiring (continued)

Wire color	Sensor terminal	Transmitter terminal
Electrode drain	 or float	

Note

For hazardous locations, refer to the product reference manual.

5.4 Wiring diagrams

Figure 5-6: Wiring using component cable

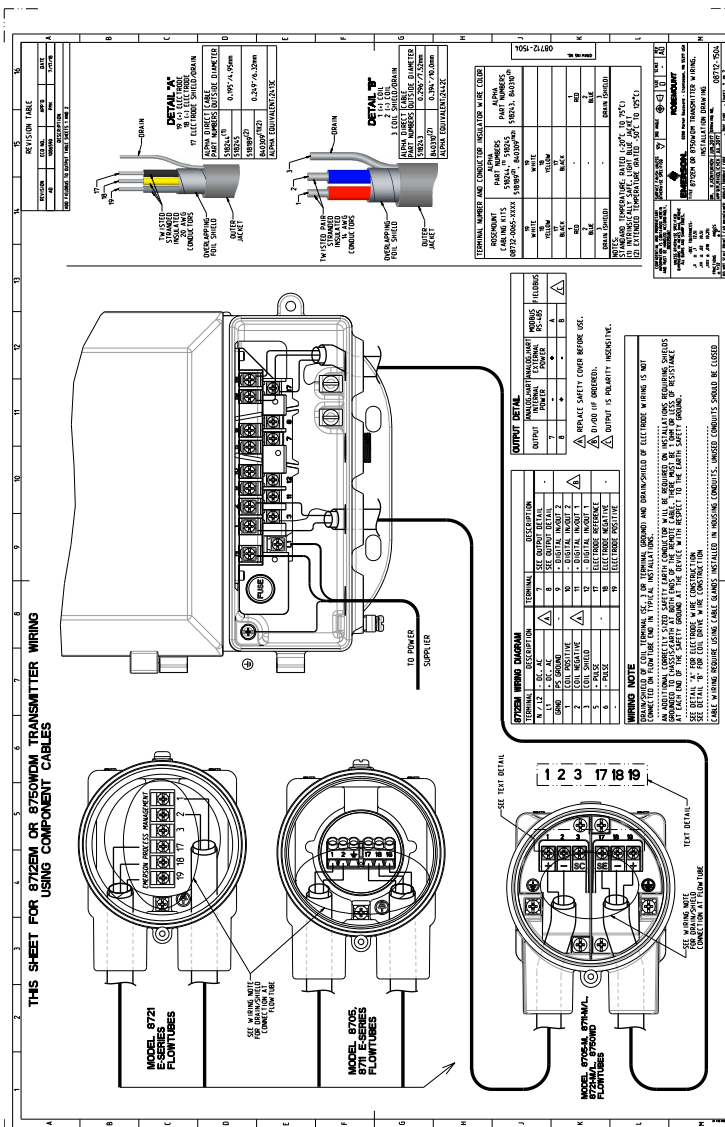
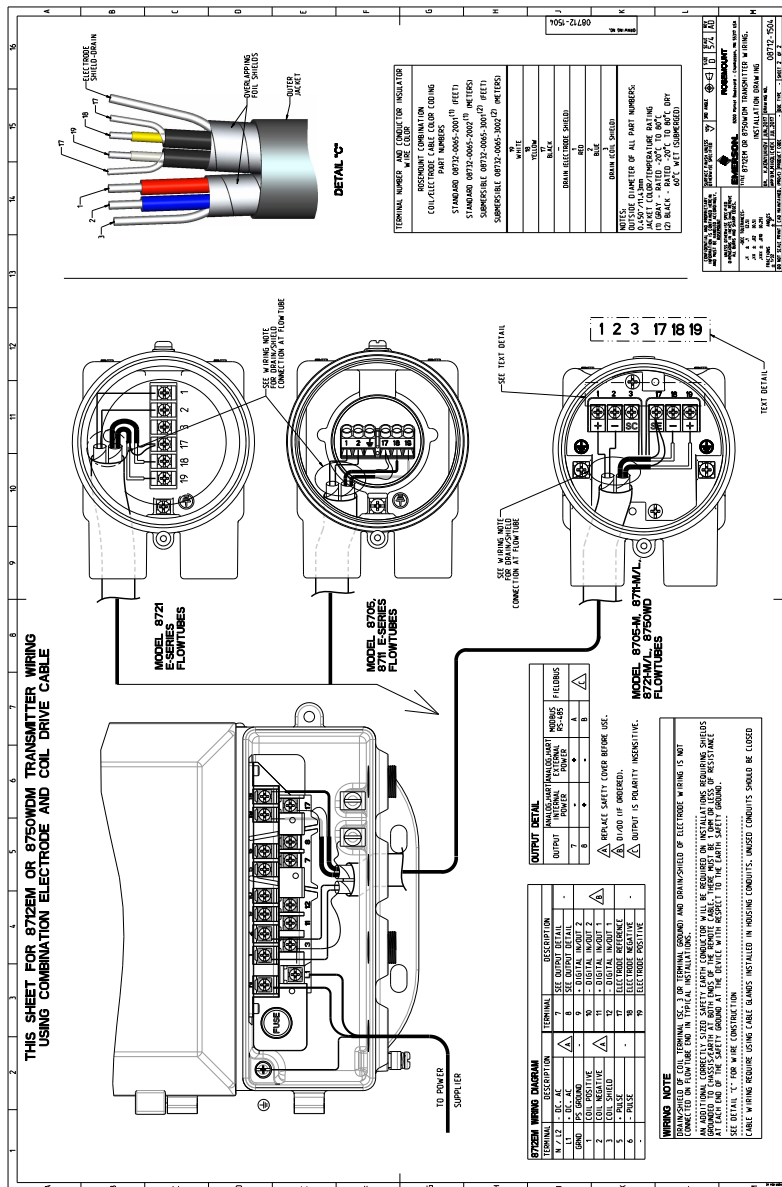

Figure 5-7: Wiring using combination cable



5.5 Power and fieldbus terminal blocks

Open the bottom cover of the transmitter to access the terminal block.

Note

To connect pulse output, refer to the product reference manual.

Figure 5-8: Terminal blocks

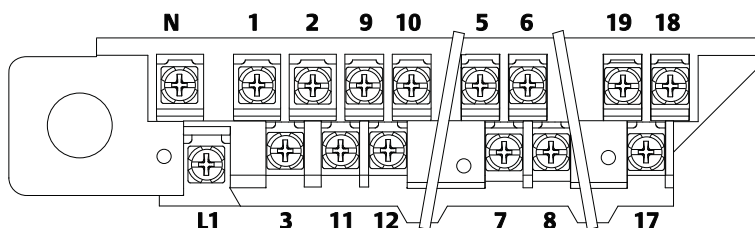

Table 5-5: Power and fieldbus terminals

Terminal number	AC version	DC version
1	Coil Positive	Coil Positive
2	Coil Negative	Coil Negative
3	Coil Shield	Coil Shield
5	Pulse (+)	Pulse (+)
6	Pulse (-)	Pulse (-)
7	D0 / A	D0 / A
8	D1 / B	D1 / B
9	Not used	Not used
10	Not used	Not used
11	Not used	Not used
12	Not used	Not used
17	Not used	Not used
18	Not used	Not used
19	Not used	Not used
N	AC (Neutral)/L2	DC (-)
L1	AC L1	DC (+)

5.6 Powering the transmitter

Before connecting power to the transmitter, be sure to have the necessary electrical supplies and required power source:

- The AC powered transmitter requires 90–250V AC (50/60Hz).
- The DC powered transmitter requires 12–42V DC.

Wire the transmitter according to national, local, and plant electrical requirements.

If installing in a hazardous location, verify that the meter has the appropriate hazardous area approval. Each meter has a hazardous area approval tag attached to the top of the transmitter housing.

AC power supply requirements

Units powered by 90 - 250VAC have the following power requirements. Peak inrush is 35.7A at 250VAC supply, lasting approximately 1ms. Inrush for other supply voltages can be estimated with: $\text{Inrush (Amps)} = \text{Supply (Volts)} / 7.0$

Figure 5-9: AC current requirements

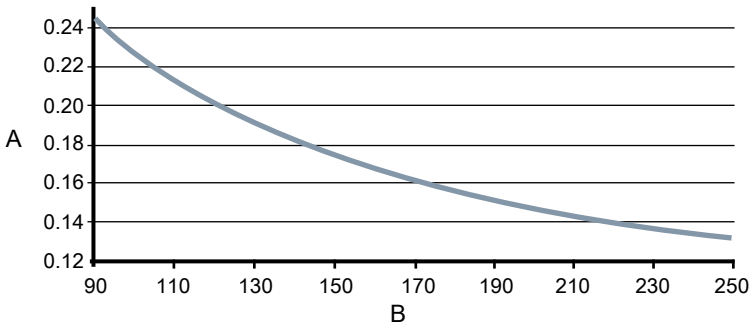

A. Supply current (amps)

B. Power supply (VAC)

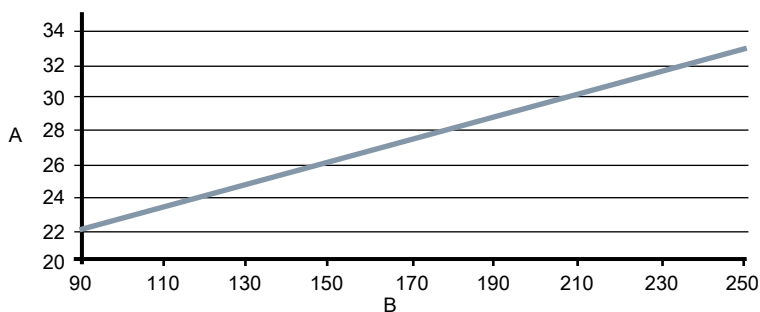
Figure 5-10: Apparent power

A. Apparent power (VA)

B. Power supply (VAC)

DC power supply requirements

Standard DC units powered by 12VDC power supply may draw up to 1.2A of current steady state. Peak inrush is 42A at 42VDC supply, lasting approximately 1ms. Inrush for other supply voltages can be estimated with:

$$\text{Inrush (Amps)} = \text{Supply (Volts)} / 1.0$$

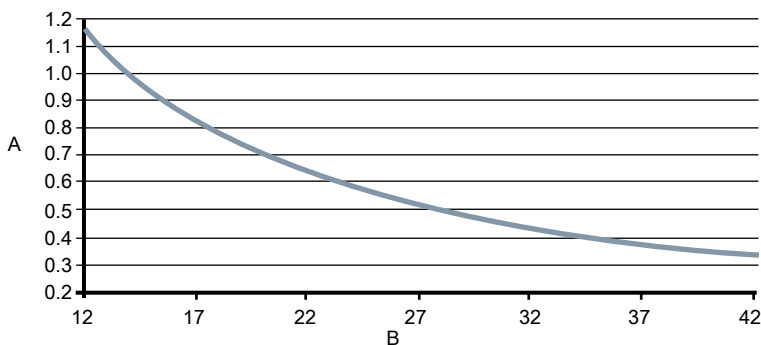
Figure 5-11: DC current requirements

A. Supply current (amps)

B. Power supply (VDC)

Supply wire requirements

Use 10–18 AWG wire rated for the proper temperature of the application. For wire 10–14 AWG use lugs or other appropriate connectors. For connections in ambient temperatures above 122 °F (50 °C), use a wire rated for 194 °F (90 °C). For DC powered transmitters with extended cable lengths,

verify that there is a minimum of 12VDC at the terminals of the transmitter with the device under load.

Electrical disconnect requirements

Connect the device through an external disconnect or circuit breaker per national and local electrical code.

Installation category

The installation category for the transmitter is OVERVOLTAGE CAT II.

Overcurrent protection

The transmitter requires overcurrent protection of the supply lines. Fuse rating and compatible fuses are shown in [Table 5-6](#).

Table 5-6: Fuse requirements

Power system	Power supply	Fuse rating	Manufacturer
AC power	90–250VAC	2 Amp quick acting	Bussman AGC2 or equivalent
DC power	12–42VDC	3 Amp quick acting	Bussman AGC3 or equivalent

Power terminals

For AC powered transmitter (90–250VAC, 50/60 Hz):

- Connect AC Neutral to Terminal N and AC Line to Terminal L1.

For DC powered transmitter:

- Connect negative to Terminal N and positive to Terminal L1.
- DC powered units may draw up to 1.2A.

Covers

Use the transmitter lower door screw to secure the terminal compartment after the instrument has been wired and powered up. Follow these steps to ensure the housing is properly sealed to meet ingress protection requirements:

1. Ensure all wiring is complete and close the lower door.
2. Tighten the lower door screw until the lower door is tight against the housing. Metal to metal contact of the screw bosses is required to ensure a proper seal.

Note

Application of excessive torque may strip the threads or break the screw.

3. Verify the lower door is secure.

5.7 Fieldbus wiring

Transmitter communication input

The FOUNDATION fieldbus communication requires a minimum of 9VDC and a maximum of 32VDC at the transmitter communication terminals. Do not exceed 32VDC at the transmitter communication terminals. Do not apply AC line voltage to the transmitter communication terminals. Improper supply voltage can damage the transmitter.

Field wiring

Power independent of the transmitter power supply must be supplied for FOUNDATION fieldbus communications. Use shielded, twisted pair for best results. In order to get maximum performance in new applications, twisted pair cable specifically designed for fieldbus communications should be used. The number of devices on a fieldbus segment is limited by the power supply voltage, the resistance of the cable, and the amount of current drawn by each device. See [Table 5-7](#) for cable specifications.

Table 5-7: Ideal cable specifications for fieldbus wiring

Characteristic	Ideal specification
Impedance	100 Ohms \pm 20% at 31.25 kHz
Wire size	18 AWG (0.8 mm ²)
Shield coverage	90%
Attenuation	3 db/km
Capacitive unbalance	2 nF/km

Power conditioning

Each fieldbus power supply requires a power conditioner to decouple the power supply output from the fieldbus wiring segment.

Figure 5-12: Power connections

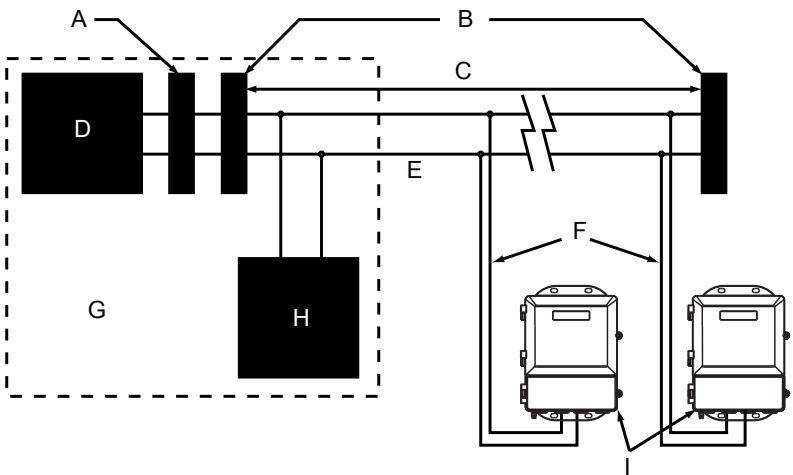

- A. Power conditioner
- B. Terminators
- C. Fieldbus segment
- D. Power supply
- E. Trunk
- F. Spurs
- G. Control room
- H. FOUNDATION fieldbus host
- I. Devices 1 through 11

Transmitter wiring connection

- Use wire terminals 7 and 8.
- The transmitter fieldbus connection is polarity insensitive.

Figure 5-13: Fieldbus wiring

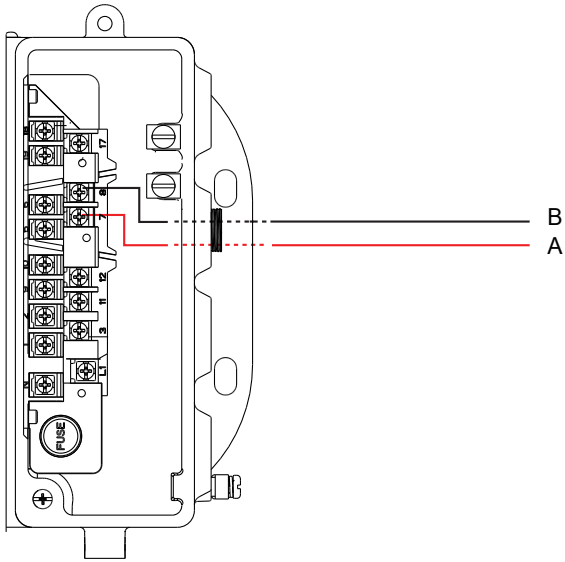

- A. Fieldbus terminal (7) D0 / A
- B. Fieldbus terminal (8) D1 / B

6 Basic Configuration

Once the magnetic flowmeter is installed and power has been supplied, the transmitter basic setup parameters must be configured with a FOUNDATION fieldbus host (See [Communication methods](#)). Configuration settings are saved in nonvolatile memory within the transmitter.

The standard transmitter configuration, without Option Code C1, Custom Configuration, is shipped with the following parameters:

- Engineering Units: ft/s
- Sensor Size: 3-in.
- Sensor Calibration Number: 100000501000000

Descriptions of more advanced functions are included in the product reference manual.

6.1 Communication methods

You will see references to the transmitter "LOI" (Local Operator Interface) in the fieldbus parameter names and on configuration screens and tools. However this type of display provides only one-way communication from the transmitter to the user for process variables, status, and diagnostics.

All configuration and other communication from the user to the transmitter requires one of two types of FOUNDATION fieldbus host:

- On an *enhanced FF host*, the transmitter parameters are displayed either in the form of a menu tree (for example, a Field Communicator) or in the form of tabbed display screens (for example, the AMS Intelligent Device Manager with DeltaV™ System). Both the menu tree and tabbed display screens are provided as part of the unique Device Description files specific to this transmitter.
- A *basic FF host* displays the transmitter parameters in the form of a list under the Resource block and transducer blocks.

This document contains information for both types of host.

Note

Fieldbus configuration tools and hosts from some vendors may interpret device information differently than others. As a result, you may notice slight differences in the paths, locations, or parameter names on your host or configuration tool.

6.2 FOUNDATION fieldbus configuration

Assigning physical device tag and node address

The transmitter is shipped with a blank physical device tag and a temporary address to allow a host to automatically assign an address and a physical device tag. If the physical device tag or address need to be changed, use the features of the configuration tool. The tools do the following:

- Change the physical device tag to a new value.
- Change the address to a new address.

When the transmitter is at a temporary address, only the physical device tag and address can be changed or written to. The resource, transducer, and function blocks are all disabled.

Flow-specific AI block configuration

The factory configuration of the four Analog Input function blocks ("AI blocks") is the following:

- One of them is configured for flow:
 - CHANNEL parameter is set to 1
 - XD_SCALE parameters are set to:
 - EU_100: -39.37
 - EU_0: -39.37
 - UNITS_INDEX: ft/sec
 - DECIMAL: 2
 - L_TYPE parameter is set to Direct
- The other three are configured as Totalizer A, Totalizer B, and Totalizer C

For more information:

- For totalizer or AI block parameter configuration, refer to the product reference manual.
- For additional AI block configuration and troubleshooting, refer to *FOUNDATION™ Fieldbus Function Blocks*, document 00809-0100-4783.

If you need to reconfigure the flow measurement AI block:

1. Set the CHANNEL parameter to 1 for flow.
2. Set the XD_SCALE parameters (EU_100, EU_0, UNITS_INDEX, and DECIMAL) to the desired measurement scale from the flow measurement transducer.
3. Set the L_TYPE parameter to the desired linearization method, and then if necessary, set the OUT_SCALE parameters:

- For direct measurement (the AI block output is the same as the XD_SCALE), set L_TYPE to Direct. This completes the channel configuration.
- For indirect measurement (the AI block output is scaled from the XD_SCALE), set L_TYPE to Indirect, and then set the OUT_SCALE parameters (EU_100, EU_0, UNITS_INDEX, and DECIMAL) to the scale required by the control/monitoring system.

General, flow-specific block configuration

In general, only the transducer block and AI blocks have configurations for flow-specific parameters. All other function blocks are configured by linking the AI blocks to other blocks to be used for control and/or monitoring applications.

6.3 Basic Setup

Descriptive tag

Enhanced FF host	Configure → Device Information → Description
Basic FF host	TB → TAG_DESC (OD Index 2)

The descriptive tag fieldbus parameter permits you to assign a 32 character identifier to a transmitter to distinguish it from others in your system. It is **not** the same as the physical device tag (see [Assigning physical device tag and node address](#)), which is used by the control scheme.

Flow units

Flow units must be configured from the AI block configured for flow measurement. See [FOUNDATION fieldbus configuration](#).

Line size

Enhanced FF host	Configure → Basic Setup
Basic FF host	TB → TUBE_SIZE (OD Index 36)

The line size (sensor size) must be set to match the actual sensor connected to the transmitter.

Calibration number

Enhanced FF host	Configure → Basic Setup
Basic FF host	TB → FLOW_TUBE_CAL_NUM (OD Index 35)

The sensor calibration number is a 16-digit number generated at the factory during flow calibration and is unique to each sensor and is located on the sensor tag.



Quick Start Guide
00825-0500-4445, Rev. AA
May 2019

Emerson Automation Solutions USA

7070 Winchester Circle
Boulder, Colorado USA 80301
T +1 303-527-5200
T +1 800-522-6277
F +1 303-530-8459
www.emerson.com

Emerson Automation Solutions Asia

1 Pandan Crescent
Singapore 128461
Republic of Singapore
T +65 6363-7766
F +65 6770-8003

Emerson Automation Solutions Europe

Neonstraat 1
6718 WX Ede
The Netherlands
T +31 (0) 70 413 6666
F +31 (0) 318 495 556
www.micromotion.nl

Emerson Automation Solutions United Kingdom

Emerson Process Management Limited
Horsfield Way
Bredbury Industrial Estate
Stockport SK6 2SU U.K.
T +44 0870 240 1978
F +44 0800 966 181

©2019 Rosemount, Inc. All rights reserved.

The Emerson logo is a trademark and service mark of Emerson Electric Co. Rosemount, 8600, 8700, 8800 marks are marks of one of the Emerson Automation Solutions family of companies. All other marks are property of their respective owners.