

Rosemount™ 8800D Vortex Flowmeter

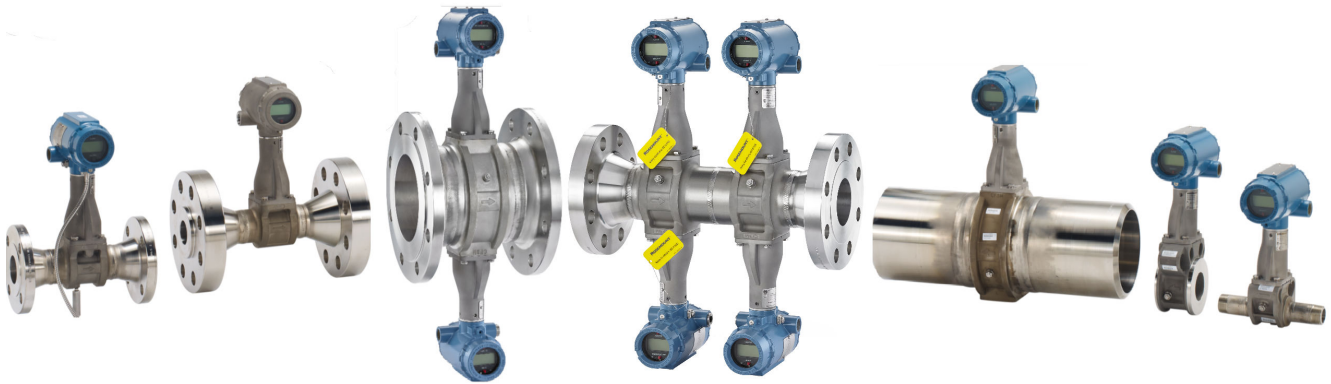

Industry Leading Vortex

- HART™, FOUNDATION™ Fieldbus, and Modbus RS-485 Protocols
- All welded, non-clog design provides maximum performance, reliability and enhanced safety by eliminating ports and gaskets.
- CriticalProcess™ increases process availability and enhances overall safety.
- SIL 2/3 Capable: IEC 61508 certified by an accredited 3rd party agency for use in safety instrumented systems up to SIL 3.
- Available with optional multivariable output. Internal temperature compensation provides cost-effective saturated steam and liquid mass flow measurement.
- Adaptive Digital Signal Processing (ADSP) provides vibration immunity and flow range optimization.
- Reducer™ Vortex extends the measurable flow range, reduces installation costs, and minimizes project risk.
- Simplified troubleshooting through device diagnostics and meter verification.
- Available in wafer, flanged, dual, quad, weld end, threaded end, reducer, and high pressure designs.

Product Overview

Rosemount 8800 selection guide

Rosemount 8800 Flanged vortex flow meter



- Wide range of flange ratings available
- Ideal for all applications from general purpose to the most demanding applications
- Available with ½ inch through 12 inch (15 mm through 300 mm) line sizes

Rosemount 8800 Reducer vortex flow meter

- Flanged vortex flow meter with reducing flanges integrated into the design
- Reduces cost by eliminating the need for field assembly of reduced piping
- Both reducer and standard vortex have a common face-to-face dimension which allows the user to change the meter without impacting the piping layout or drawing
- Available with 1 inch through 14 inch (25 mm to 350 mm) line sizes



Contents

| | |
|---|----|
| Product Overview..... | 2 |
| Flow rate sizing..... | 10 |
| Ordering Information - Single/Dual Transmitter..... | 11 |
| Ordering information – Quad transmitter..... | 19 |
| Product Specifications..... | 28 |
| Product certifications..... | 54 |
| Dimensional drawings..... | 55 |

Rosemount 8800 MultiVariable vortex flow meter



- Integral temperature sensor enables temperature compensated mass flow for saturated steam and liquids
 - Incorporates temperature sensor into the vortex meter using the shedder bar as a thermowell, which keeps the vortex and temperature sensors isolated from process for easy verification and replacement
 - Capability to capture a pressure input from a HART pressure device for pressure compensation mass flow for saturated steam
 - Pressure and Temperature compensation mass flow for Superheated Steam
 - Superheat Diagnostics allows for an alert and/or alarm to activate when degrees of superheat are close to saturated conditions.
 - Available with integrated thermowell for 1½ inch through 12 inch (40 mm through 300 mm) Flanged and 2 inch through 12 inch (50 mm through 300 mm) Reducer Vortex meter body sizes
-

Rosemount 8800 Wafer vortex flow meter

- Lightweight, cost-effective solution
- Easy installation with standard alignment rings
- Ideal for utility applications
- Available with ½ inch through 8 inch (15 mm through 200 mm) line sizes



Rosemount 8800 Weld-end vortex flow meter



- Flange gaskets are eliminated by welding the flow meter directly into your process piping
 - The only vortex flow meter available with zero potential leak points
 - Ideal for applications where reducing potential leak points is important
 - Available with ½ inch through 12 inch (15 mm through 300 mm) line sizes
-

Rosemount 8800 Threaded End vortex flow meter

- Easy installation by matching existing threaded pipe union
- Reduce cost by eliminating flanged connections
- Available for ½ inch through 2 inch (15 mm through 50 mm) and 1 inch through 2 inch (25 mm through 50 mm) Reducer meter body sizes



Rosemount 8800 Dual vortex flow meter



- Flanged vortex flow meter with redundant electronics and sensors
- Use for SIS and other applications where redundancy is critical
- Available with ½ inch through 12 inch (15 mm through 300 mm) line sizes

Rosemount 8800 Quad vortex flow meter

- Emerson delivers an integrated quadruple sensor configuration providing 2oo3 voting plus an additional independent output for process control
- Reduce installation costs with a simple drop-in solution
- Decrease operating expenses and maintenance over traditional dP orifice flow meters
- Excellent rangeability and no need for zeroing
- Couple with the CriticalProcess (CPA) option to ensure ultimate safety and reliability
- Transmitters available with independent configurations
- Available with 2 inch through 12 inch (50 mm through 300 mm) line sizes

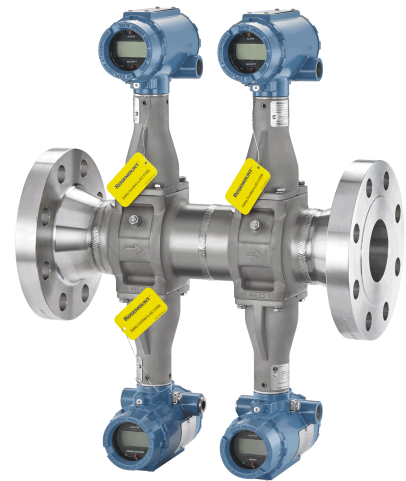

The Rosemount 8800D delivers reliability, safety, and maximum process availability



- Rosemount Reliability—The Rosemount 8800D Vortex eliminates impulse lines, ports, and gaskets to improve reliability.
- Non-clog Design—Unique all welded, gasket-free construction which has no ports or crevices that can clog.
- SIL 2/3 Capable - The Rosemount 8800D Vortex is certified by an accredited 3rd party agency for use in safety instrumented systems up to SIL 3 (minimum requirement of single use [1oo1] for SIL 2 and redundant use [1oo2] for SIL 3).
- Vibration Immunity—Mass balancing of the sensor system, and Adaptive Digital Signal Processing (ADSP) provide vibration immunity.
- Replaceable Sensor—The sensor is isolated from the process and can be replaced without breaking the process seal. All line sizes use the same sensor design allowing a single spare to serve every meter.
- Simplified Troubleshooting—Device Diagnostics enable field verification of meter electronics and sensor without process shutdown.

The Rosemount 8800D Critical Process Vortex increases process availability and enhances overall safety



Eliminate bypass piping for critical process installations

Traditional vortex installations in critical applications include a bypass line to allow process fluid to be re-directed around the vortex flow meter during routine sensor maintenance. Rosemount's unique non-wetted sensor can be installed without bypass piping, even in the most difficult process environments.

Improve process availability

Eliminate the need to shut down the process during routine maintenance and meter verification.

Enhances safety in hazardous process fluid applications

A Critical Process Valve (CPA option) enables access to the sensor cavity to verify that no process fluid is present.

Boost reliability, confidence, and control while reducing safety risks, maintenance costs, and down time in liquid and steam flow applications with the Rosemount 8800D MultiVariable™ flowmeter



Gain confidence in your mass flow measurement accuracy

Emerson MultiVariable Vortex provides the highest level of accurate steam mass flow over the widest range using an external pressure and/or internal temperature measurement to capture your dynamic operating conditions. This delivers the confidence required for your billing statements and also achieves better control in steam applications.

Reduce safety risks and maintenance burdens associated with many-component measurement solutions

By selecting Emerson MultiVariable Vortex, the safety risk to operators is reducing while at the same time, the maintenance required is reduced and simplified. The plant area shutdown requirements are reduced while performing maintenance or verification tasks, which also reduces the cost implications of being offline.

Overcome challenges of steam mass-flow measurement with a more durable solution

Emerson MultiVariable Vortex delivers the performance confidence and system reliability required in steam applications. Cost implications related to poor quality steam, complex system architecture and process shutdowns are eliminated by reducing vulnerability to leakage, clogging, plugging and freezing.

Reduced installation complexity with the Remote Transmitter



For installations where the transmitter must be located remotely from the sensor, two remote cable styles are available:

- Standard cable can be used for applications where environmental or physical damage is unlikely, or if the cable will be enclosed in conduit.
- Armored cable should be used when maximum reliability or resistance to environmental and physical damage are a concern. Cable glands of appropriate metal type are provided.

Both cable types are offered in standard lengths (10, 20, 33, 50, and 75 ft [3, 6, 10, 15, and 23 meters]). Standard cable can also be ordered in custom lengths.

Detect process fluid change from liquid to gas with SMART Fluid Diagnostics

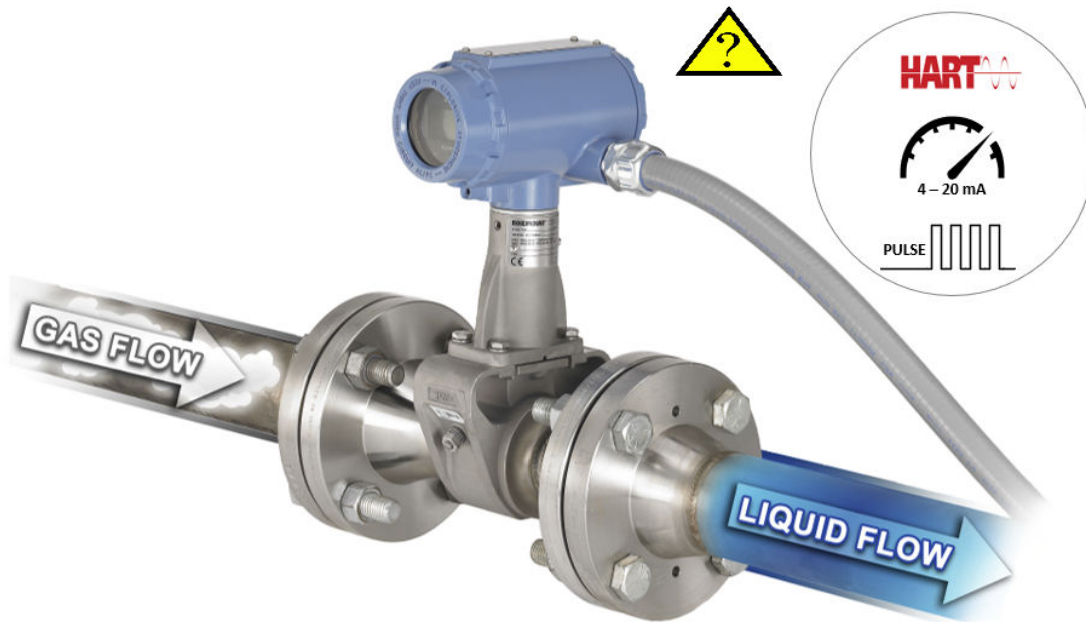

Oil and gas separators

- Remotely detect when your separator dump valve allows gas to pass through your water dump leg.
- Selectable alert modes (digital, analog or pulse) signal when gas flow is detected.

Steam, nitrogen, or air blow down

- Control your clean in place (CIP) or blow down cycles with a single meter that measures the flow rate of your primary process fluid as well as the change from liquid to gas flow.
- Set your control system to control down cycle based on alert from in-line vortex meter.
- Selectable alert modes (digital, analog or pulse) signal when gas flow is detected.

Provide comparison to external time reference with Elapsed Time Meter

- Running totalizer of hours of operation
- Accuracy 1 hour per year maximum deviation



Access process variables and diagnostics locally with the optional LCD Display



The optional 11 digit, two-line integral LCD display can be configured to alternate between selected display options, such as flow, totalizer, mA output, temperature (MTA/MCA) and pressure (MPA/MCA). Diagnostics and fault conditions, when present, will also appear on the display for local troubleshooting.

Access information when you need it with asset tags

Newly shipped devices include a unique QR code asset tag that enables you to access serialized information directly from the device. With this capability, you can:

- Access device drawings, diagrams, technical documentation, and troubleshooting information in your MyEmerson account
- Improve mean time to repair and maintain efficiency
- Ensure confidence that you have located the correct device
- Eliminate the time-consuming process of locating and transcribing nameplates to view asset information.

Flow rate sizing

Sizing calculations are required to select the proper flow meter size. These calculations provide pressure loss, accuracy, minimum and maximum flow rate data to guide in proper selection. Vortex sizing software can be found using the Selection and Sizing tool. The Selection and Sizing tool can be accessed online or downloaded for offline use using this link:

www.Emerson.com/FlowSizing

For reference for typical flow rates for common applications, please see [Typical flow rates](#) or refer to product reference manual 00809-0100-4004 or 00809-1100-4004.

Ordering Information - Single/Dual Transmitter

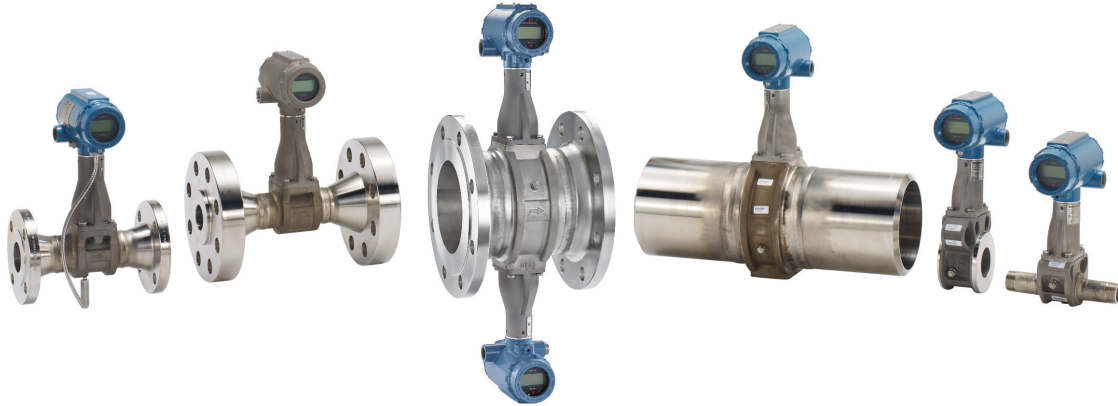

Model code structure

In conjunction with a complete model code string, we strongly recommend every meter be configured at the factory for your application. Use the Rosemount 8800D Configuration Data Sheet ([00806-0100-4004](#)) to convey your configuration information to the factory.

Figure 1: Guide to model code structure

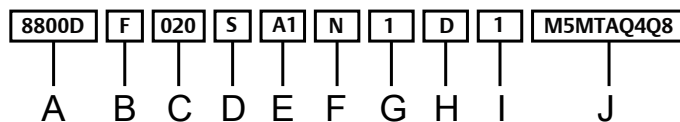

- A. Model
- B. Meter style
- C. Line size
- D. Wetted material
- E. Process connection & pressure rating
- F. Sensor process temperature range
- G. Housing material & conduit entries
- H. Output options
- I. Calibration
- J. Options

Example model code with one selection out of each required category:

8800D F 020 S A1 N 1 D 1 M5 MTA Q4 Q8

The starred (★) offerings represent the best delivery options.

Requirements

Table 1: Requirements - select one from each available choice

| Code | Description | |
|---|--|---|
| Base model | | |
| 8800D | Vortex Flow Meter | ★ |
| Meter style | | |
| F | Standard body style for use with flanged, welded, and threaded process connections | ★ |
| W | Wafer body style for use with wafer-style process connections | ★ |
| R | Reducer – Meter body is one nominal size smaller than line size selection for use with flanged or threaded process connections | ★ |
| D ⁽¹⁾ | Dual-sensor for use with flanged, welded, and threaded process connections | |
| Line size | | |
| 005 ⁽²⁾ | ½ inch (15 mm) | ★ |
| 010 | 1 inch (25 mm) | ★ |
| 015 | 1½ inch (40 mm) | ★ |
| 020 | 2 inch (50 mm) | ★ |
| 030 | 3 inch (80 mm) | ★ |
| 040 | 4 inch (100 mm) | ★ |
| 060 | 6 inch (150 mm) | ★ |
| 080 | 8 inch (200 mm) | ★ |
| 100 | 10 inch (250 mm) | |
| 120 | 12 inch (300 mm) | |
| 140 ⁽³⁾ | 14 inch (350 mm) | |
| Wetted materials | | |
| S | 316 wrought stainless and CF-3M cast stainless; Material of construction is 316/316L. | ★ |
| H ⁽⁴⁾ | UNS N06022 wrought nickel alloy; CW2M cast nickel alloy. | |
| C | A105 forged carbon steel and WCB cast carbon steel | |
| L | LF2 forged carbon steel and LCC cast carbon steel | |
| D ⁽⁵⁾ | UNS S32760 wrought duplex stainless steel and 6A cast duplex stainless steel | |
| Process connection style and pressure rating | | |
| A1 | ASME B16.5 RF Class 150 | ★ |
| A3 | ASME B16.5 RF Class 300 | ★ |
| A6 | ASME B16.5 RF Class 600 | |
| A7 ⁽⁶⁾ | ASME B16.5 RF Class 900 | |
| A8 ⁽⁷⁾ | ASME B16.5 RF Class 1500 | |
| K0 | EN 1092-1 PN 10 Type B1 | |
| K1 | EN 1092-1 PN 16 (PN 10/16 for wafer style) Type B1 | ★ |
| K2 | EN 1092-1 PN 25 Type B1 | |

Table 1: Requirements - select one from each available choice (continued)

| Code | Description | |
|-------------------|--|---|
| K3 | EN 1092-1 PN 40 (PN 25/40 for wafer style) Type B1 | ★ |
| K4 | EN 1092-1 PN 63 Type B1 | |
| K6 | EN 1092-1 PN 100 Type B1 | |
| K7 ⁽⁶⁾ | EN 1092-1 PN 160 Type B1 | |
| K8 ⁽⁷⁾ | EN 1092-1 PN 250 Type B1 | |
| B1 ⁽⁸⁾ | ASME B16.5 RTJ Class 150 for flange-style only | |
| B3 | ASME B16.5 RTJ Class 300 for flange-style only | |
| B6 | ASME B16.5 RTJ Class 600 for flange-style only | |
| B7 ⁽⁶⁾ | ASME B16.5 RTJ Class 900 for flange-style only | |
| B8 ⁽⁷⁾ | ASME B16.5 RTJ Class 1500 for flange-style only | |
| C1 | ASME B16.5 RF Class 150, smooth finish | |
| C3 | ASME B16.5 RF Class 300, smooth finish | |
| C6 | ASME B16.5 RF Class 600, smooth finish | |
| C7 ⁽⁶⁾ | ASME B16.5 RF Class 900, smooth finish | |
| C8 ⁽⁷⁾ | ASME B16.5 RF Class 1500, smooth finish | |
| J1 | JIS 10K | |
| J2 | JIS 20K | |
| J4 | JIS 40K | |
| L0 | EN 1092-1 PN 10 Type B2 | |
| L1 | EN 1092-1 PN 16 (PN 10/16 for wafer style) Type B2 | |
| L2 | EN 1092-1 PN 25 Type B2 | |
| L3 | EN 1092-1 PN 40 (PN 25/40 for wafer style) Type B2 | |
| L4 | EN 1092-1 PN 63 Type B2 | |
| L6 | EN 1092-1 PN 100 Type B2 | |
| L7 ⁽⁶⁾ | EN 1092-1 PN 160 Type B2 | |
| M0 | EN 1092-1 PN 10 Type D for flange style only | |
| M1 | EN 1092-1 PN 16 Type D for flange style only | |
| M2 | EN 1092-1 PN 25 Type D for flange style only | |
| M3 | EN 1092-1 PN 40 Type D for flange style only | |
| M4 | EN 1092-1 PN 63 Type D for flange style only | |
| M6 | EN 1092-1 PN 100 Type D for flange style only | |
| M7 ⁽⁶⁾ | EN 1092-1 PN 160 Type D for flange style only | |
| N0 | EN 1092-1 PN 10 Type F | |
| N1 | EN 1092-1 PN 16 Type F | |
| N2 | EN 1092-1 PN 25 Type F | |

Table 1: Requirements - select one from each available choice (continued)

| Code | Description | |
|---|--|---|
| N3 | EN 1092-1 PN 40 Type F | |
| N4 | EN 1092-1 PN 63 Type F | |
| N6 | EN 1092-1 PN 100 Type F | |
| N7 ⁽⁶⁾ | EN 1092-1 PN 160 Type F | |
| T8 ⁽⁹⁾ | Threaded End process connections, NPT, Schedule 80S | |
| T9 ⁽¹⁰⁾ | Threaded End process connections, NPT, Schedule 160S | |
| W1 ⁽¹¹⁾ | Weld-end, Schedule 10S | |
| W4 ⁽¹¹⁾ | Weld-end, Schedule 40S | |
| W8 ⁽⁸⁾⁽¹¹⁾ | Weld-end, Schedule 80S | |
| W9 ⁽¹¹⁾ | Weld-end, Schedule 160S | |
| Sensor process temperature range | | |
| N ⁽¹²⁾ | Standard: -40 to +450 °F (-40 to +232 °C) | ★ |
| E ⁽¹²⁾ | Extended: -330 to +800 °F (-200 to +427 °C) | ★ |
| S ⁽¹²⁾ | Severe service: -330 to +842 °F (-200 to +450 °C) and nickel alloy construction for increased corrosion resistance | ★ |
| Housing material and conduit entries | | |
| 1 | Aluminum housing, two ½-14 NPT conduit entries | ★ |
| 2 ⁽¹³⁾ | Aluminum housing, two M20 x 1.5 conduit entries | ★ |
| 3 ⁽¹³⁾ | Aluminum housing, two PG 13.5 conduit adapters | ★ |
| 4 | Aluminum housing, one G1/2 conduit adapter (one conduit entry) | ★ |
| 5 | Aluminum housing, two G1/2 conduit adapters (two conduit entries) | ★ |
| 6 | Stainless steel housing, two ½-14 NPT conduit entries | |
| 7 ⁽¹³⁾ | Stainless steel housing, two M20 x 1.5 conduit entries | |
| Outputs | | |
| D | 4-20 mA digital electronics (HART protocol) | ★ |
| P | 4-20 mA digital electronics (HART protocol) with scaled pulse | ★ |
| F ⁽¹⁴⁾⁽¹⁵⁾ | FOUNDATION Fieldbus digital signal | ★ |
| M ⁽¹⁴⁾⁽¹⁵⁾ | Modbus RS-485 (device status and 4 dynamic variables) | ★ |
| Calibration | | |
| 1 | Flow calibration | ★ |

(1) Duals from ½ inch through 4 inch (15 mm through 100 mm) have dual bar meter body design. Duals from 6 inch through 12 inch (150 mm through 350 mm) have single bar meter body design. Please contact an Emerson Flow representative (see back page) for more information on 2 inch through 4 inch (50 mm to 100 mm) on single bar dual meter body design.

(2) Not available for Rosemount 8800DR.

(3) Code 140 (14 inch [350 mm]) size is only available with reducer.

(4) See Table 15 for collared vs. weld neck flange configuration.

(5) Available in Flanged and Dual from 6 inch through 12 inch and Reducer from 8 inch through 12 inch Class 1500 in 6 inch and 8 inch meter body sizes and Class 900 in 10 inch through 12 inch meter body sizes.

- (6) Available on flanged and dual style meters from ½ inch through 8 inch (15–200 mm) and reducer style meters from 1 inch through 8 inch (25–200 mm). Also available in 10 inch through 12 inch (250-300 mm) flanged and dual meters along with 12 inch (300 mm) reducers when using Super Duplex material of construction.
- (7) Only available for flange and dual style meters from 1 inch through 8 inch (25–200 mm).
- (8) Not available with ½ inch line size.
- (9) Available with Meter style code F and D from ½ inch through 2 inch (15 mm through 50 mm) line sizes and Meter style code R (reducer) in 1 inch (25 mm) line sizes with Wetted materials codes S and D.
- (10) Available in Meter style code F and D from ½ inch through 2 inch (15 mm through 50 mm) line sizes and Meter style code R (reducer) in 1½ inch and 2 inch (40 mm and 50 mm) line sizes with Wetted materials codes S and D.
- (11) Only available with Meter Style F or D.
- (12) See [Table 10](#) and [Table 14](#) for the specific sensor process temperature range. Meters that include the PD option code are compliant with the EU Pressure Equipment Directive, PED, 2014/68/EU and the UK Pressure Equipment (Safety) Regulation, PER, Statutory Instrument, SI No. 1105.
- (13) No Japan (E4) approval.
- (14) The Safety Certifications SI option code is not available with this option.
- (15) MultiVariable option codes MPA and MCA not available with this option.

Options

Select only as needed.

Table 2: Options

| Code | Description | |
|---------------------------------|--|---|
| Hazardous area approvals | | |
| E5 | US Approvals Explosion-proof and Dust Ignition-proof | ★ |
| I5 | US Approvals Intrinsically Safe and Non-Incendive | ★ |
| IE ⁽¹⁾ | US Approvals FISCO Intrinsically Safe and Non-Incendive | ★ |
| K5 | US Approvals Explosion-proof, Dust Ignition-proof, Intrinsically Safe, and Non-Incendive | ★ |
| E6 | US/Canadian Approvals Explosion-proof and Dust Ignition-proof | ★ |
| I6 | US/Canadian Approvals Intrinsically Safe and Division 2 | ★ |
| IF ⁽¹⁾ | US/Canadian Approvals FISCO Intrinsically Safe and Division 2 | ★ |
| K6 | US/Canadian Approvals Explosion-proof, Dust Ignition-proof, Intrinsically Safe, and Division 2 | ★ |
| KB | US/Canadian Approvals Explosion-proof, Dust Ignition-proof, Intrinsically Safe, and Division 2 | ★ |
| E1 | ATEX Flameproof | ★ |
| I1 | ATEX Intrinsic Safety ia; Intrinsic Safety ic | ★ |
| IA ⁽¹⁾ | ATEX FISCO Intrinsic Safety | ★ |
| N1 | ATEX Type n | ★ |
| ND | ATEX Dust | ★ |
| K1 | ATEX Flameproof; Intrinsic Safety; Type n; Dust | ★ |
| E7 | IECEX Flameproof | ★ |
| I7 | IECEX Intrinsic Safety | ★ |
| IG ⁽¹⁾ | IECEX FISCO Intrinsic Safety | ★ |
| N7 | IECEX Type n | ★ |
| NF | IECEX Dust | ★ |
| K7 | IECEX Flameproof; Intrinsic Safety; Type n; Dust | ★ |
| E2 | INMETRO Flameproof | ★ |
| I2 | INMETRO Intrinsic Safety | ★ |

Table 2: Options (continued)

| Code | Description | |
|-----------------------------|---|---|
| IB ⁽¹⁾ | INMETRO FISCO Intrinsic Safety | ★ |
| K2 | INMETRO Flameproof; Intrinsic Safety | ★ |
| E3 | China Flameproof | ★ |
| I3 | China Intrinsic Safety | ★ |
| N3 | China Type n | ★ |
| IH ⁽¹⁾ | China FISCO/FNICO Intrinsic Safety | ★ |
| K3 | China Flameproof; Dust; Intrinsic Safety; Type n | ★ |
| E4 | Japan Flameproof | ★ |
| E8 | Technical Regulations Customs Union (EAC) Flameproof | ★ |
| I8 | Technical Regulations Customs Union (EAC) Intrinsic Safety | ★ |
| N8 | Technical Regulations Customs Union (EAC) Type n | ★ |
| K8 | Technical Regulations Customs Union (EAC) Flameproof; Intrinsic Safety; Type n | ★ |
| G8 | Technical Regulations Customs Union (EAC) FISCO Intrinsic Safety | ★ |
| MultiVariable | | |
| MTA ⁽²⁾⁽³⁾ | MultiVariable output with temperature compensation and integral temperature sensor | ★ |
| MPA ⁽²⁾⁽⁴⁾⁽⁵⁾ | MultiVariable output with pressure compensation | ★ |
| MCA ⁽²⁾⁽³⁾⁽⁴⁾⁽⁵⁾ | MultiVariable output with pressure and temperature compensation and integral temperature sensor | ★ |
| Display type | | |
| M5 | LCD indicator | ★ |
| Remote electronics | | |
| R10 | Remote electronics with 10 ft (3,0 m) cable | ★ |
| R20 | Remote electronics with 20 ft (6,1 m) cable | ★ |
| R30 | Remote electronics with 30 ft (9,1 m) cable | ★ |
| R33 | Remote electronics with 33 ft (10,1m) cable | ★ |
| R50 | Remote electronics with 50 ft (15,2 m) cable | ★ |
| R75 | Remote electronics with 75 ft (22,9 m) cable | ★ |
| Rxx | Remote Electronics with customer-specified cable length (xx ft., 1 ft to 75 ft cable in 1 ft increments) Example: R15 = 15 ft, R34 = 34 ft | |
| A10 | Armored remote electronics with 10 ft (3,0 m) cable | |
| A20 | Armored remote electronics with 20 ft (6,1 m) cable | |
| A33 | Armored remote electronics with 33 ft (10,1 m) cable | |
| A50 | Armored remote electronics with 50 ft (15,2 m) cable | |
| A75 | Armored remote electronics with 75 ft (22,9 m) cable | |

Table 2: Options (continued)

| Code | Description | |
|---|--|---|
| Transient protection | | |
| T1 | Transient Protection terminal block | ★ |
| Alarm mode | | |
| C4 ⁽⁶⁾ | NAMUR alarm and saturation values, high alarm | ★ |
| CN ⁽⁶⁾ | NAMUR alarm and saturation values, low alarm | ★ |
| Special cleaning | | |
| P2 | Cleaning for special services | ★ |
| Ground screw assembly | | |
| V5 ⁽⁷⁾ | External ground screw assembly | ★ |
| Plantweb™ control functionality | | |
| A01 ⁽⁸⁾ | Basic Control: One Proportional/Integral/Derivative (PID) Function Block | ★ |
| ASME B31.1 code compliance⁽⁹⁾ | | |
| J2 | ASME B31.1 General compliance | |
| J7 | ASME B31.1 Boiler External Piping (BEP) code stamp | |
| Conduit electrical connectors | | |
| GE ⁽¹⁰⁾⁽⁵⁾ | M12, 4-pin, Male Connector (eurofast™) | |
| GM ⁽¹⁰⁾⁽⁵⁾ | A size Mini, 4-pin, Male Connector (minifast™) | |
| GN ⁽⁵⁾ | ATEX Flameproof A size, Mini 4-pin male connector (minifast) | |
| HART revision configuration | | |
| HR7 ⁽⁴⁾⁽⁵⁾ | HART Revision 7 | ★ |
| Process diagnostics | | |
| DS3 ⁽²⁾⁽⁴⁾⁽⁵⁾ | Smart Fluid Diagnostics | ★ |
| Safety certifications | | |
| SJ ⁽⁴⁾⁽⁵⁾ | Safety Certification of 4–20 mA Output per IEC 61508 | ★ |
| Quality certificate | | |
| Q4 | Calibration Certificate per ISO 10474 3.1/EN 10204 3.1 | ★ |
| Q5 | Hydrostatic Test Certificate | ★ |
| Q8 | Material Traceability per ISO 10474 3.1/EN 10204 3.1 | ★ |
| QP | Calibration Certificate per ISO 10474 3.1/EN 10204 3.1 and Tamper Evident Seal | ★ |
| Q25 | Certificate of Compliance to NACE MR0175 and MR0103 | ★ |
| Q66 | Weld procedure package (weld map, weld procedure specification, weld procedure qualification record, welder performance qualification) | ★ |
| Q70 ⁽¹¹⁾ | NDE Weld Examination Inspection Certificate, ISO 10474 3.1; see Table 28 | |
| Q71 ⁽¹¹⁾ | NDE Weld Examination Inspection Certificate, ISO 10474 3.1 with images; see Table 28 | |
| Q76 | Positive Material Identification (PMI) on Flanges and Pipe (XRF), per ASTM E1476-97; see Table 29 . | ★ |

Table 2: Options (continued)

| Code | Description | |
|--|--|---|
| Q77 | Positive Material Identification (PMI) with Carbon Content on Flange and Pipe (OES) per ASTM E1476-97; see Table 30 . | ★ |
| Q80 ⁽¹²⁾ | Ferrite Content Testing (FN 3 to 10) | ★ |
| Sensor completion | | |
| WG | Witness General | |
| Pressure Equipment Directive (PED) | | |
| PD | Pressure Equipment Directive (PED) | ★ |
| Shipboard approvals | | |
| SBS ⁽¹³⁾ | American Bureau of Shipping (ABS) type approval | ★ |
| SBV ⁽¹³⁾ | Bureau Veritas (BV) type approval | ★ |
| SDN ⁽¹³⁾ | Det Norske Veritas (DNV) type approval | ★ |
| Critical process vortex | | |
| CPA | Critical Process Online Sensor Replacement Not available on: <ul style="list-style-type: none"> ■ Any wafer-style meter (Meter style code W) ■ Any ½ inch (15 mm) flange (Meter style code F) or 1 inch (25 mm) reducer (Meter style code R) ■ 1 inch (25 mm) flange (Meter style code F) or 1½ inch (40 mm) reducer (Meter style code R) with JIS 10K, EN PN40, or PN16 flange rating ■ Meters with Wetted Material option code D ■ 6 inch (150 mm) or larger meters with Wetted Material option code H | |
| Elapsed time meter | | |
| ETM ⁽⁴⁾⁽⁵⁾ | Elapsed time meter | ★ |
| Quick Start Guide language (default is English) | | |
| YF | French | ★ |
| YG | German | ★ |
| YI | Italian | ★ |
| YJ | Japanese | ★ |
| YK | Korean | ★ |
| YM | Chinese (Mandarin) | ★ |
| YP | Portuguese | ★ |
| YR | Russian | ★ |
| YS | Spanish | ★ |

(1) *Fieldbus Intrinsic Safe Concept (FISCO) available with output code F (Foundation Fieldbus digital signal) only.*

(2) *The Safety Certifications SI option code is not available with this option.*

(3) *Available with Rosemount 8800DF from 1½ inch through 12 inch (40 mm through 300 mm). Available with 8800DR from 2 inch through 12 inch (50 mm through 300 mm). Consult an Emerson Flow representative (see back page) for line sizes smaller than 1½ inch (40 mm). Not available with 8800DW or 8800DD.*

(4) *Output option code F not available with this option.*

(5) *Output option code M not available with this option.*

- (6) NAMUR compliant operation and the alarm latch options are preset at the factory and can be changed to standard operation in the field.
- (7) Only available for ordinary location. The ground screw is included by default for all hazardous area approvals.
- (8) Requires output code F.
- (9) Requires Quality Certificate Q4, Q5, Q8, and NDE Welding Certificate Q70 or Q71.
- (10) Not available with certain hazardous location certifications. Contact an Emerson Flow representative for details (see back page).
- (11) Available with material option codes S, C, L and H; not available with Meter Style option code W in 1 inch through 4 inch (25 mm through 100 mm) line sizes.
- (12) Only available with Material option code S.
- (13) Not available with Output option code M.

Ordering information – Quad transmitter

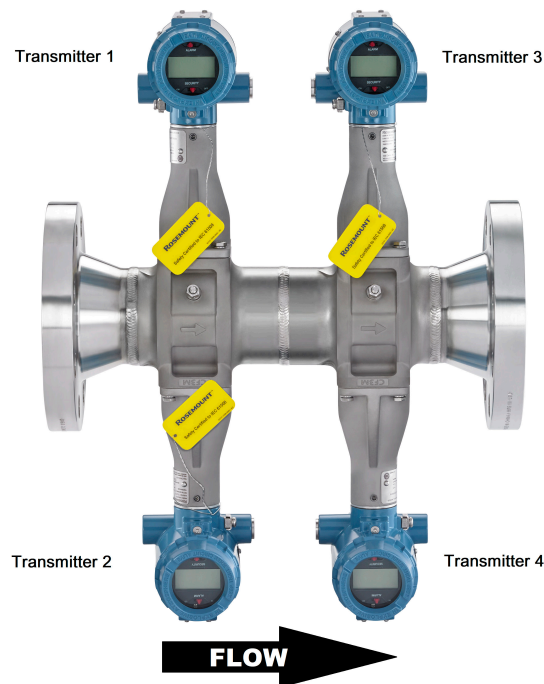

Model code structure

The outputs and hazardous approvals must be specified for each of the four transmitters on a quad transmitter vortex flow meter. As a result, the model code string in those two sections has an entry for each transmitter. The model code string for all other requirements and options has only a single entry applicable to the entire meter. We strongly recommend that every meter, and each transmitter, be configured at the factory for your application. Use the Rosemount 8800D Quad Configuration Data Sheet (00806-1100-4004) to convey your configuration information to the factory. Example model code with one selection out of each required category:

Figure 2: Guide to model code structure

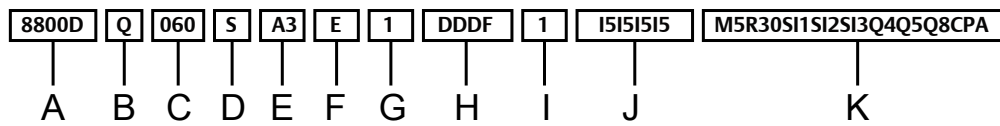

- A. Model
- B. Meter style
- C. Line size
- D. Wetted material
- E. Process connection & pressure rating
- F. Sensor process temperature range
- G. Housing material & conduit entries
- H. Output options (each transmitter)
- I. Calibration
- J. Hazardous area approvals (each transmitter)
- K. Options

Example model string: 8800DQ 060 S A3 E 1 DDDF 1 15I5I5IE M5 R30 S11 S12 S13 Q4 Q5 Q8 CPA

The starred (★) offerings represent the best delivery options.

Requirements

Table 3: Requirements - select one from each available choice

| Code | Description | |
|-------------------------|---|---|
| Base model | | |
| 8800D | Vortex Flow Meter | ★ |
| Style | | |
| Q | Quad transmitter (two shedder bars and four transmitters), flanged | ★ |
| Line size | | |
| 020 ⁽¹⁾ | 2 inch (50 mm) | ★ |
| 030 ⁽¹⁾ | 3 inch (80 mm) | ★ |
| 040 ⁽¹⁾ | 4 inch (100 mm) | ★ |
| 060 | 6 inch (150 mm) | ★ |
| 080 | 8 inch (200 mm) | |
| 100 | 10 inch (250 mm) | |
| 120 | 12 inch (300 mm) | |
| Wetted materials | | |
| S | 316 wrought stainless and CF-3M cast stainless; Material of construction is 316/316L. | ★ |
| H | UNS N06022 wrought nickel alloy; CW2M cast nickel alloy; weld neck flange | |
| C | A105 forged carbon steel and WCB cast carbon steel | |
| L | LF2 forged carbon steel and LCC cast carbon steel | |
| D ⁽²⁾ | UNS S32760 wrought duplex stainless steel and 6A cast duplex stainless steel | |

Table 3: Requirements - select one from each available choice (continued)

| Code | Description | |
|---|---|---|
| Process connection style and pressure rating | | |
| A1 | ASME B16.5 RF Class 150 | ★ |
| A3 | ASME B16.5 RF Class 300 | ★ |
| A6 | ASME B16.5 RF Class 600 | |
| A7 ⁽³⁾ | ASME B16.5 RF Class 900 | |
| A8 ⁽⁴⁾ | ASME B16.5 RF Class 1500 | |
| K0 | EN 1092-1 PN 10 Type B1 | |
| K1 | EN 1092-1 PN 16 Type B1 | ★ |
| K2 | EN 1092-1 PN 25 Type B1 | |
| K3 | EN 1092-1 PN 40 Type B1 | ★ |
| K4 | EN 1092-1 PN 63 Type B1 | |
| K6 | EN 1092-1 PN 100 Type B1 | |
| K7 ⁽³⁾ | EN 1092-1 PN 160 Type B1 | |
| B1 | ASME B16.5 RTJ Class 150 | |
| B3 | ASME B16.5 RTJ Class 300 | |
| B6 | ASME B16.5 RTJ Class 600 | |
| B7 ⁽³⁾ | ASME B16.5 RTJ Class 900 | |
| B8 ⁽⁴⁾ | ASME B16.5 RTJ Class 1500 | |
| C1 | ASME B16.5 RF Class 150, smooth finish | |
| C3 | ASME B16.5 RF Class 300, smooth finish | |
| C6 | ASME B16.5 RF Class 600, smooth finish | |
| C7 ⁽³⁾ | ASME B16.5 RF Class 900, smooth finish | |
| C8 ⁽⁴⁾ | ASME B16.5 RF Class 1500, smooth finish | |
| J1 | JIS 10K | |
| J2 | JIS 20K | |
| J4 | JIS 40K | |
| L0 | EN 1092-1 PN 10 Type B2 | |
| L1 | EN 1092-1 PN 16 Type B2 | |
| L2 | EN 1092-1 PN 25 Type B2 | |
| L3 | EN 1092-1 PN 40 Type B2 | |
| L4 | EN 1092-1 PN 63 Type B2 | |
| L6 | EN 1092-1 PN 100 Type B2 | |
| L7 ⁽³⁾ | EN 1092-1 PN 160 Type B2 | |

Table 3: Requirements - select one from each available choice (continued)

| Code | Description | |
|---|--|---|
| M0 | EN 1092-1 PN 10 Type D | |
| M1 | EN 1092-1 PN 16 Type D | |
| M2 | EN 1092-1 PN 25 Type D | |
| M3 | EN 1092-1 PN 40 Type D | |
| M4 | EN 1092-1 PN 63 Type D | |
| M6 | EN 1092-1 PN 100 Type D | |
| M7 ⁽³⁾ | EN 1092-1 PN 160 Type D | |
| N0 | EN 1092-1 PN 10 Type F | |
| N1 | EN 1092-1 PN 16 Type F | |
| N2 | EN 1092-1 PN 25 Type F | |
| N3 | EN 1092-1 PN 40 Type F | |
| N4 | EN 1092-1 PN 63 Type F | |
| N6 | EN 1092-1 PN 100 Type F | |
| N7 ⁽³⁾ | EN 1092-1 PN 160 Type F | |
| W1 | Weld-end, Schedule 10S | |
| W4 | Weld-end, Schedule 40S | |
| W8 | Weld-end, Schedule 80S | |
| W9 | Weld-end, Schedule 160S | |
| Sensor process temperature range | | |
| N ⁽⁵⁾ | Standard: -40 to +450 °F (-40 to +232 °C) | ★ |
| E ⁽⁵⁾ | Extended: -330 to +800 °F (-200 to +427 °C) | ★ |
| S ⁽⁵⁾ | Severe service: -330 to +842 °F (-200 to +450 °C) and nickel alloy construction for increased corrosion resistance | ★ |
| Housing material and conduit entries | | |
| 1 | Aluminum housing, two ½-14 NPT conduit entries | ★ |
| 2 ⁽⁶⁾ | Aluminum housing, two M20 x 1.5 conduit entries | ★ |
| 3 ⁽⁶⁾ | Aluminum housing, two PG 13.5 conduit adapters | ★ |
| 4 | Aluminum housing, one G1/2 conduit adapter (one conduit entry) | ★ |
| 5 | Aluminum housing, two G1/2 conduit adapters (two conduit entries) | ★ |
| 6 | Stainless steel housing, two ½-14 NPT conduit entries | |
| 7 ⁽⁶⁾ | Stainless steel housing, two M20 x 1.5 conduit entries | |
| Transmitter 1, 2, 3, 4 output (Make a selection for each transmitter in order) | | |
| D | 4-20 mA digital electronics (HART protocol) | ★ |
| P | 4-20 mA digital electronics (HART protocol) with scaled pulse | ★ |
| F ⁽⁷⁾ | FOUNDATION Fieldbus digital signal | ★ |

Table 3: Requirements - select one from each available choice (continued)

| Code | Description | |
|---|--|---|
| M ⁽⁷⁾ | Modbus RS-485 (device status and 4 dynamic variables) | ★ |
| Calibration | | |
| 1 | Flow calibration | ★ |
| Hazardous area approvals for transmitter 1, 2, 3, 4 (Make a selection for each transmitter in order, all approvals must be from one group) | | |
| Hazardous area approvals Group A | | |
| NH | Ordinary location (non-hazardous) | ★ |
| Hazardous area approvals Group B | | |
| E5 | US Approvals Explosion-proof and Dust Ignition-proof | ★ |
| I5 | US Approvals Intrinsically Safe and Non-Incendive | ★ |
| IE ⁽⁸⁾ | US Approvals FISCO Intrinsically Safe and Non-Incendive | ★ |
| K5 | US Approvals Explosion-proof, Dust Ignition-proof, Intrinsically Safe, and Non-Incendive | ★ |
| Hazardous area approvals Group C | | |
| E6 | US/Canadian Approvals Explosion-proof and Dust Ignition-proof | ★ |
| I6 | US/Canadian Approvals Intrinsically Safe and Division 2 | ★ |
| IF ⁽⁸⁾ | US/Canadian Approvals FISCO Intrinsically Safe and Division 2 | ★ |
| K6 | US/Canadian Approvals Explosion-proof, Dust Ignition-proof, Intrinsically Safe, and Division 2 | ★ |
| KB | US/Canadian Approvals Explosion-proof, Dust Ignition-proof, Intrinsically Safe, and Division 2 | ★ |
| Hazardous area approvals Group D | | |
| E1 | ATEX Flameproof | ★ |
| I1 | ATEX Intrinsic Safety ia; Intrinsic Safety ic | ★ |
| IA ⁽⁸⁾ | ATEX FISCO Intrinsic Safety | ★ |
| N1 | ATEX Type n | ★ |
| ND | ATEX Dust | ★ |
| K1 | ATEX Flameproof; Intrinsic Safety; Type n; Dust | ★ |
| Hazardous area approvals Group E | | |
| E7 | IECEx Flameproof | ★ |
| I7 | IECEx Intrinsic Safety | ★ |
| IG ⁽⁸⁾ | IECEx FISCO Intrinsic Safety | ★ |
| N7 | IECEx Type n | ★ |
| NF | IECEx Dust | ★ |
| K7 | IECEx Flameproof; Intrinsic Safety; Type n; Dust | ★ |

Table 3: Requirements - select one from each available choice (continued)

| Code | Description | |
|---|--|---|
| Hazardous area approvals Group F | | |
| E2 | INMETRO Flameproof | ★ |
| I2 | INMETRO Intrinsic Safety | ★ |
| IB ⁽⁸⁾ | INMETRO FISCO Intrinsic Safety | ★ |
| K2 | INMETRO Flameproof; Intrinsic Safety | ★ |
| Hazardous area approvals Group G | | |
| E3 | China Flameproof | ★ |
| I3 | China Intrinsic Safety | ★ |
| N3 | China Type n | ★ |
| IH ⁽⁸⁾ | China FISCO/FNICO Intrinsic Safety | ★ |
| K3 | China Flameproof; Dust; Intrinsic Safety; Type n | ★ |
| Hazardous area approvals Group H | | |
| E4 | Japan Flameproof | ★ |
| Hazardous area approvals Group I | | |
| E8 | Technical Regulations Customs Union (EAC) Flameproof | ★ |
| I8 | Technical Regulations Customs Union (EAC) Intrinsic Safety | ★ |
| N8 | Technical Regulations Customs Union (EAC) Type n | ★ |
| K8 | Technical Regulations Customs Union (EAC) Flameproof; Intrinsic Safety; Type n | ★ |
| G8 | Technical Regulations Customs Union (EAC) FISCO Intrinsic Safety | ★ |

(1) Only available with remote electronics.

(2) Available in Class 1500 in 6 inch and 8 inch meter body sizes and Class 900 in 10 inch through 12 inch meter body sizes.

(3) Available on meters from 2 inch through 8 inch (50–200 mm). Also available in 10 inch through 12 inch (250–300 mm) meters when using Super Duplex material of construction.

(4) Only available for meters from 2 inch through 8 inch (50–200 mm).

(5) See Table 10 and Table 14 for the specific sensor process temperature range. Meters that include the PD option code are compliant with the EU Pressure Equipment Directive, PED, 2014/68/EU and the UK Pressure Equipment (Safety) Regulation, PER, Statutory Instrument, SI No. 1105.

(6) No Japan (E4) approval.

(7) The Safety Certifications SI1, SI2, SI3, or SI4 option codes are not available with this option.

(8) Fieldbus Intrinsic Safe Concept (FISCO) available with output code F (Foundation Fieldbus digital signal) only.

Options

Select only as needed.

Table 4: Options

| Code | Description | |
|---|---|---|
| Display type⁽¹⁾ | | |
| M5 | LCD indicator | ★ |
| Remote electronics⁽¹⁾ | | |
| R10 | Remote electronics with 10 ft (3,0 m) cable | ★ |
| R20 | Remote electronics with 20 ft (6,1 m) cable | ★ |
| R30 | Remote electronics with 30 ft (9,1 m) cable | ★ |

Table 4: Options (continued)

| Code | Description | |
|---|---|---|
| R33 | Remote electronics with 33 ft (10,1m) cable | ★ |
| R50 | Remote electronics with 50 ft (15,2 m) cable | ★ |
| R75 | Remote electronics with 75 ft (22,9 m) cable | ★ |
| Rxx | Remote Electronics with customer-specified cable length (xx ft., 1 ft to 75 ft cable in 1 ft increments) Example: R15 = 15 ft, R34 = 34 ft | |
| A10 | Armored remote electronics with 10 ft (3,0 m) cable | |
| A20 | Armored remote electronics with 20 ft (6,1 m) cable | |
| A33 | Armored remote electronics with 33 ft (10,1 m) cable | |
| A50 | Armored remote electronics with 50 ft (15,2 m) cable | |
| A75 | Armored remote electronics with 75 ft (22,9 m) cable | |
| Transient protection⁽¹⁾ | | |
| T1 | Transient Protection terminal block | |
| Alarm mode⁽¹⁾ | | |
| C4 ⁽²⁾ | NAMUR alarm and saturation values, high alarm | ★ |
| CN ⁽²⁾ | NAMUR alarm and saturation values, low alarm | ★ |
| Special cleaning | | |
| P2 | Cleaning for special services | ★ |
| Ground screw assembly⁽¹⁾ | | |
| V5 ⁽³⁾ | External ground screw assembly | ★ |
| Plantweb™ control functionality | | |
| A01 ⁽⁴⁾ | Basic Control: One Proportional/Integral/Derivative (PID) Function Block | ★ |
| ASME B31.1 code compliance⁽⁵⁾ | | |
| J2 | ASME B31.1 General compliance | |
| J7 | ASME B31.1 Boiler External Piping (BEP) code stamp | |
| HART communication⁽¹⁾ | | |
| HR7 ⁽⁷⁾ | HART Revision 7 | ★ |
| Process diagnostics⁽¹⁾ | | |
| DS3 ⁽⁶⁾⁽⁷⁾ | SMART Fluid Diagnostics | ★ |
| Safety certifications for Transmitter 1 | | |
| SI1 ⁽⁶⁾ | Safety Certification of 4–20 mA Output per IEC 61508 | ★ |
| Safety certifications for Transmitter 2 | | |
| SI2 ⁽⁶⁾ | Safety Certification of 4–20 mA Output per IEC 61508 | ★ |
| Safety certifications for Transmitter 3 | | |
| SI3 ⁽⁶⁾ | Safety Certification of 4–20 mA Output per IEC 61508 | ★ |

Table 4: Options (continued)

| Code | Description | |
|--|--|---|
| Safety certifications for Transmitter 4 | | |
| SI4 ⁽⁶⁾ | Safety Certification of 4–20 mA Output per IEC 61508 | ★ |
| Quality certificate | | |
| Q4 | Calibration Certificate per ISO 10474 3.1/EN 10204 3.1 | ★ |
| Q5 | Hydrostatic Test Certificate | ★ |
| Q8 | Material Traceability per ISO 10474 3.1/EN 10204 3.1 | ★ |
| QP | Calibration Certificate per ISO 10474 3.1/EN 10204 3.1 and Tamper Evident Seal | ★ |
| Q25 | Certificate of Compliance to NACE MR0175 and MR0103 | ★ |
| Q66 | Weld Procedure Package (weld map, weld procedure specification, weld procedure qualification record, welder performance qualification) | ★ |
| Q70 | NDE Weld Examination Inspection Certificate, ISO 10474 3.1; see Table 28 | |
| Q71 | NDE Weld Examination Inspection Certificate, ISO 10474 3.1 with images; see Table 28 | |
| Q76 | Positive Material Identification (PMI) on Flanges and Pipe (XRF), per ASTM E1476-97; see Table 29 . | ★ |
| Q77 | Positive Material Identification (PMI) with Carbon Content on Flange and Pipe (OES) per ASTM E1476-97; see Table 30 . | ★ |
| Q80 ⁽⁸⁾ | Ferrite Content Testing (FN 3 to 10) | ★ |
| Sensor completion | | |
| WG | Witness General | |
| Pressure Equipment Directive (PED) | | |
| PD | Pressure Equipment Directive (PED) | ★ |
| Shipboard approvals⁽¹⁾ | | |
| SBS ⁽⁹⁾ | American Bureau of Shipping (ABS) type approval | ★ |
| SBV ⁽⁹⁾ | Bureau Veritas (BV) type approval | ★ |
| SDN ⁽⁹⁾ | Det Norske Veritas (DNV) type approval | ★ |
| Critical process vortex⁽¹⁾ | | |
| CPA | Critical Process Online Sensor Replacement Not available on: <ul style="list-style-type: none"> ■ Meters with Wetted Material option code D ■ 6 inch (150 mm) or larger meters with Wetted Material option code H | ★ |
| Quick Start Guide language (default is English) | | |
| YF | French | ★ |
| YG | German | ★ |
| YI | Italian | ★ |
| YJ | Japanese | ★ |
| YK | Korean | ★ |
| YM | Chinese (Mandarin) | ★ |

Table 4: Options (continued)

| Code | Description | |
|------|-------------|---|
| YP | Portuguese | ★ |
| YR | Russian | ★ |
| YS | Spanish | ★ |

- (1) Option code will apply to all applicable transmitters.
- (2) NAMUR compliant operation and the alarm latch options are preset at the factory and can be changed to standard operation in the field.
- (3) Only available for ordinary location. The ground screw is included by default for all hazardous area approvals.
- (4) Only applies to transmitters ordered with output code F.
- (5) Requires Quality Certificate Q4, Q5, Q8, and NDE Welding Certificate Q70 or Q71.
- (6) Not available with Outputs option codes F and M.
- (7) The Safety Certifications S11, S12, S13, or S14 option codes are not available with this option.
- (8) Only available with Material code S.
- (9) Not available with Output option code M.

Product Specifications

Physical specifications

Rosemount vortex flow meters are designed to the standards defined in ASME B31.3. This standard is used as the basis for all of our other pressure vessel certifications such as CRN and PED.

Process fluids

Liquid, Gas, and Steam applications. Fluids must be homogeneous and single-phase.

Flow calibration

Every Emerson Vortex flowmeter is water calibrated and given a unique calibration number called a reference K-factor. Emerson flow labs use traceable calibrations that reference internationally recognized standards such as NIST in the United States and Mexico, National Institute of Standards in China, and ISO 10725 in Europe.

Theoretical and experimental data have shown that the K-factor is independent of fluid density and viscosity, proving the K-factor is applicable in all types of fluid—liquid, gas and steam. The K-factor is a function of the shedder bar and meter geometry.

Line sizes and pipe schedules

Table 5: Line sizes by process connection type

| Line size | | Process connection type (✓ indicates availability) | | | | | | | |
|-----------|-----|--|------|---------|------|-------|----------|----------|---------|
| Inch | DIN | Flanged | | | | Wafer | Weld-end | Threaded | |
| | | Standard | Dual | Reducer | Quad | | | Standard | Reducer |
| 0.5 | 15 | ✓ | ✓ | | | ✓ | ✓ | ✓ | |
| 1 | 25 | ✓ | ✓ | ✓ | | ✓ | ✓ | ✓ | ✓ |
| 1.5 | 40 | ✓ | ✓ | ✓ | | ✓ | ✓ | ✓ | ✓ |
| 2 | 50 | ✓ | ✓ | ✓ | ✓ | ✓ | ✓ | ✓ | ✓ |
| 3 | 80 | ✓ | ✓ | ✓ | ✓ | ✓ | ✓ | | |
| 4 | 100 | ✓ | ✓ | ✓ | ✓ | ✓ | ✓ | | |
| 6 | 150 | ✓ | ✓ | ✓ | ✓ | ✓ | ✓ | | |
| 8 | 200 | ✓ | ✓ | ✓ | ✓ | ✓ | ✓ | | |
| 10 | 250 | ✓ | ✓ | ✓ | ✓ | | ✓ | | |
| 12 | 300 | ✓ | ✓ | ✓ | ✓ | | ✓ | | |
| 14 | 350 | | | ✓ | | | | | |

Process pipe schedules

Meters will be shipped from the factory at the Schedule 40 default value unless otherwise specified. The value can be changed in the field if necessary.

For a weld-end style meter, see [Table 9](#).

Pressure limits

Table 6: Flanged/Dual/Quad style meter

| ASME 16.5 | EN1092-1 | JIS |
|-----------|----------|-----|
| Class 150 | PN 10 | 10K |
| Class 300 | PN 16 | 20K |

Table 6: Flanged/Dual/Quad style meter (continued)

| ASME 16.5 | EN1092-1 | JIS |
|------------|----------|-----|
| Class 600 | PN 25 | 40K |
| Class 900 | PN 40 | |
| Class 1500 | PN 63 | |
| | PN 100 | |
| | PN 160 | |

Table 7: Reducer style meter

| ASME 16.5 | EN1092-1 |
|------------|----------|
| Class 150 | PN 10 |
| Class 300 | PN 16 |
| Class 600 | PN 25 |
| Class 900 | PN 40 |
| Class 1500 | PN 63 |
| | PN 100 |
| | PN 160 |

Table 8: Wafer style meter

| ASME 16.5 | EN1092-1 | JIS |
|-----------|----------|-----|
| Class 150 | PN 10 | 10K |
| Class 300 | PN 16 | 20K |
| Class 600 | PN 25 | 40K |
| | PN 40 | |
| | PN 63 | |
| | PN 100 | |

Table 9: Weld-end/Threaded-end style meter

| | W1 | W4 | W8/T8 | W9/T9 |
|--|-----------------------|-------------------------|-------------------------|-------------------------|
| Mating pipe schedule: | Schedule 10 | Schedule 40 | Schedule 80 | Schedule 160 |
| Pressure rating for 1 inch to 4 inch sizes: | 720 psig (4.96 MPa-g) | 1,440 psig (9.93 MPa-g) | 2,160 psig (14.9 MPa-g) | 3,600 psig (24.8 MPa-g) |
| Pressure rating for 6 inch to 12 inch sizes: | N/A | 720 psig (4.96 MPa-g) | 1,440 psig (9.93 MPa-g) | 2,160 psig (14.9 MPa-g) |

Temperature limits

Table 10: Vortex Sensor process temperature range⁽¹⁾

| Standard Process Temperature: Option Code N | | |
|---|---|---|
| Wetted material | PED/PER ⁽²⁾ | NOT PED/PER |
| S | -40 °F to +450 °F (-40 °C to +232 °C) | |
| H | -40 °F to +450 °F (-40 °C to +232 °C) | |
| C | +32 °F to +450 °F (0 °C to +232 °C) | -20 °F to +450 °F (-29 °C to +232 °C) |
| L | -40 °F to +450 °F (-40 °C to +232 °C) | |
| D | -40 °F to +450 °F (-40 °C to +232 °C) | |
| Extended Process Temperature: Option Code E | | |
| Wetted material | PED/PER ⁽²⁾ | NOT PED/PER |
| S | -320 °F to +800 °F (-196 °C to +427 °C) | |
| H | -157 °F to +800 °F (-105 °C to +427 °C) | -325 °F to +800 °F (-198 °C to +427 °C) |
| C | +32 °F to +800 °F (0 °C to +427 °C) | -20 °F to +800 °F (-29 °C to +427 °C) |
| L | -50 °F to +800 °F (-46 °C to +427 °C) | |
| D | -58 °F to +600 °F (-50 °C to +315 °C) | -60 °F to +600 °F (-51 °C to +315 °C) |
| Severe Service: Option Code S | | |
| Wetted material | PED/PER ⁽²⁾ | NOT PED/PER |
| S | -320 °F to +842 °F (-196 °C to +450 °C) | |
| H | -157 °F to +800 °F (-105 °C to +427 °C) | -330 °F to +800 °F (-201 °C to +427 °C) |
| C | +32 °F to +800 °F (0 °C to +427 °C) | -20 °F to +800 °F (-29 °C to +427 °C) |
| L | -50 °F to +800 °F (-46 °C to +427 °C) | |
| D | -58 °F to +600 °F (-50 °C to +315 °C) | -60 °F to +600 °F (-51 °C to +315 °C) |

(1) Ambient and process temperature limits maybe be modified by the hazardous area rating. Please refer to [Table 14](#) and to [Rosemount 8800D Approval Document \(00825-VA00-0001\)](#).

(2) Meters that include the PD option code are compliant with the EU Pressure Equipment Directive, PED, 2014/68/EU and the UK Pressure Equipment (Safety) Regulation, PER, 2016 Statutory Instrument, SI No. 1105.

Table 11: Temperature sensor temperature limits

| Temperature sensor | Temperature limit |
|---------------------|--|
| Type N thermocouple | -40 °F to +842 °F (-40 °C to +450 °C) ⁽¹⁾ |

(1) Meets ASTM E230/E230M-17 Special Tolerance Standard.

Table 12: Electronics temperature limits (remotely-mounted transmitter)

| | |
|--|---------------------------------------|
| Ambient operating temperature range ⁽¹⁾ | -58 °F to +185 °F (-50 °C to +85 °C) |
| Ambient operating temperature range with LCD—Local Indicator ⁽¹⁾⁽²⁾ | -40 °F to +185 °F (-40 °C to +85 °C) |
| Storage temperature range | -58 °F to +250 °F (-50 °C to +121 °C) |
| Storage temperature range with LCD | -50 °F to +185 °F (-46 °C to +85 °C) |

(1) Ambient operating temperature limits maybe be modified by the hazardous area rating. Please refer to [Rosemount 8800D Approval Document \(00825-VA00-0001\)](#).

(2) LCD contrast may be affected below -4°F (-20°C).

Table 13: Electronics temperature limits (integrally-mounted transmitter)

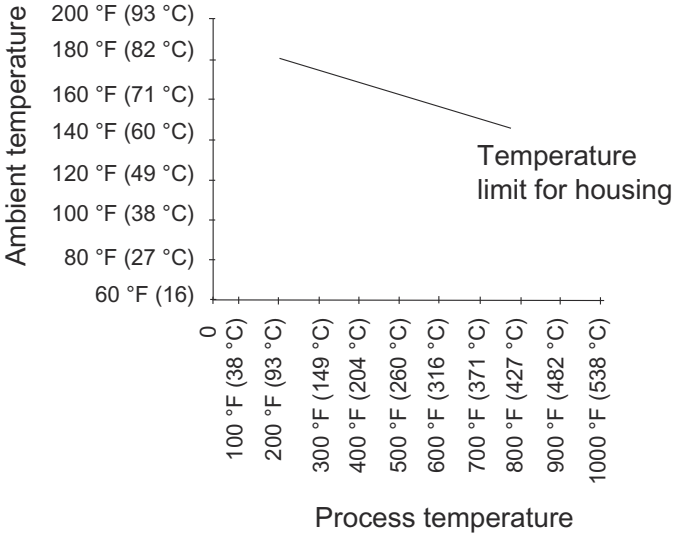
| Operating and storage temperature range, with and without LCD | Same as remotely-mounted transmitter. See Table 12 . However, high process temperature lowers the maximum allowable ambient temperature. See Figure 3 . | | | | | | | | | | | | | | | | | | | | | | | | |
|---|--|-------------------------------|-------------------------------|-------|----------|----------|----------|----------|----------|-----------|----------|-----------|----------|-----------|----------|-----------|----------|-----------|----------|-----------|----------|-----------|---------|------------|---------|
| Maximum process temperature ⁽¹⁾ | <p>Interdependent with ambient temperature. Figure 3 indicates the combined ambient and process temperature limits under which the electronics temperature can be maintained below the maximum $+185^{\circ}\text{F}$ ($+85^{\circ}\text{C}$).</p> <p>Note The indicated limit is with the integral transmitter directly above a horizontal pipe, and the pipe insulated with three inches of ceramic fiber. Other configurations may affect the actual electronics temperature.</p> <p>Figure 3: Maximum ambient/process temperature limit</p>  <table border="1"> <caption>Data points for Figure 3: Maximum ambient/process temperature limit</caption> <thead> <tr> <th>Process temperature (°F / °C)</th> <th>Ambient temperature (°F / °C)</th> </tr> </thead> <tbody> <tr> <td>0 (0)</td> <td>185 (85)</td> </tr> <tr> <td>100 (38)</td> <td>175 (79)</td> </tr> <tr> <td>200 (93)</td> <td>165 (74)</td> </tr> <tr> <td>300 (149)</td> <td>155 (69)</td> </tr> <tr> <td>400 (204)</td> <td>145 (64)</td> </tr> <tr> <td>500 (260)</td> <td>135 (58)</td> </tr> <tr> <td>600 (316)</td> <td>125 (52)</td> </tr> <tr> <td>700 (371)</td> <td>115 (47)</td> </tr> <tr> <td>800 (427)</td> <td>105 (41)</td> </tr> <tr> <td>900 (482)</td> <td>95 (35)</td> </tr> <tr> <td>1000 (538)</td> <td>85 (29)</td> </tr> </tbody> </table> | Process temperature (°F / °C) | Ambient temperature (°F / °C) | 0 (0) | 185 (85) | 100 (38) | 175 (79) | 200 (93) | 165 (74) | 300 (149) | 155 (69) | 400 (204) | 145 (64) | 500 (260) | 135 (58) | 600 (316) | 125 (52) | 700 (371) | 115 (47) | 800 (427) | 105 (41) | 900 (482) | 95 (35) | 1000 (538) | 85 (29) |
| Process temperature (°F / °C) | Ambient temperature (°F / °C) | | | | | | | | | | | | | | | | | | | | | | | | |
| 0 (0) | 185 (85) | | | | | | | | | | | | | | | | | | | | | | | | |
| 100 (38) | 175 (79) | | | | | | | | | | | | | | | | | | | | | | | | |
| 200 (93) | 165 (74) | | | | | | | | | | | | | | | | | | | | | | | | |
| 300 (149) | 155 (69) | | | | | | | | | | | | | | | | | | | | | | | | |
| 400 (204) | 145 (64) | | | | | | | | | | | | | | | | | | | | | | | | |
| 500 (260) | 135 (58) | | | | | | | | | | | | | | | | | | | | | | | | |
| 600 (316) | 125 (52) | | | | | | | | | | | | | | | | | | | | | | | | |
| 700 (371) | 115 (47) | | | | | | | | | | | | | | | | | | | | | | | | |
| 800 (427) | 105 (41) | | | | | | | | | | | | | | | | | | | | | | | | |
| 900 (482) | 95 (35) | | | | | | | | | | | | | | | | | | | | | | | | |
| 1000 (538) | 85 (29) | | | | | | | | | | | | | | | | | | | | | | | | |

(1) Ambient operating temperature limits maybe be modified by the hazardous area rating. Please refer to [Rosemount 8800D Approval Document \(00825-VA00-0001\)](#).

EMI/RFI effect

- Meets EMC requirements to Directive 2014/30/EU.
- Output error less than $\pm 0.025\%$ of span with twisted pair from 80–1000 MHz for radiated field strength of 10 V/m.
- 1.4–2.0 GHz for radiated field strength of 3 V/m.
- 2.0–2.7 GHz for radiated field strength of 1 V/m.
- No affect on the values that are being given if using HART digital signal.
- Tested per EN61326.

Humidity limits

Operates in 0–95% relative humidity under noncondensing conditions (tested to IEC 60770, Section 6.2.11).

Remote transmitter mounting hardware and cables

- Mounting hardware is provided.
- The transmitter and meter body are interconnected by a standard or armored signal cable assembly.
 - Cable length is specified when ordered (see [Ordering Information - Single/Dual Transmitter](#) or [Ordering information – Quad transmitter](#)), and it cannot be altered in the field.

- Standard cable is non-armored and is intended to be run through rigid metal conduit.
- Armored cable includes glands/adapters to connect the cable to the meter body and transmitter.
- Both types of cable are flame resistant in accordance with IEC 60322-3.

Tagging

- Standard tags are stainless steel.
- The standard tag is permanently attached to the flowmeter.
- Character height is 1/16 inch (1,6 mm).
- A wired-on tag is available on request.
- Character height on the wire-on tag is 0.236 inch (6 mm).
- Wire on tags can contain five lines with an average of 19 characters per line at standard character height.

Materials of construction

Wetted components

Table 14: Sensor hazardous location process temperature limits (°C)⁽¹⁾

| Ambient temperature (°C) | Process temperature (°C) | T-Class Sensor |
|---------------------------------|-----------------------------------|----------------|
| -50 °C to +70 °C ⁽¹⁾ | -200 °C to +75 °C | T6 |
| -50 °C to +70 °C ⁽¹⁾ | -200 °C to +95 °C | T5 |
| -50 °C to +70 °C ⁽¹⁾ | -200 °C to +130 °C | T4 |
| -50 °C to +70 °C ⁽¹⁾ | -200 °C to +195 °C | T3 |
| -50 °C to +70 °C ⁽¹⁾ | -200 °C to +290 °C | T2 |
| -50 °C to +70 °C ⁽¹⁾ | -200 °C to +450 °C ⁽²⁾ | T1 |

(1) Temperatures noted only apply to Flameproof, Ex d, models. Please refer to [Rosemount 8800D Approval Document \(00825-VA00-0001\)](#) for the specific temperature limits for each hazardous area approval code.

(2) The user is responsible for ensuring the surface temperature does not exceed 450 °C in their specific installation.

Table 15: Material of construction details for wetted material code H (for single/dual transmitters only)

| Line size in. (mm) | Flange rating code | | | | | | | | |
|-----------------------|--------------------|----|----|----|----|----|----|----|----|
| | A1 | A3 | A6 | A7 | K1 | K3 | K4 | K6 | K7 |
| ½ (15) | C | C | C | W | W | W | NA | W | W |
| 1 (25) | C | C | C | W | W | W | NA | W | W |
| 1½ (40) | C | C | C | W | W | W | NA | W | W |
| 2 (50) | C | C | C | W | C | C | W | W | W |
| 3 (80) | C | C | C | W | C | C | W | W | W |
| 4 (100) | C | C | C | W | C | C | W | W | W |
| 6 (150) | C | C | C | W | W | W | W | W | W |
| 8 (200) | C | C | C | W | W | W | W | W | W |
| 10 (250) | W | W | W | NA | W | W | W | W | NA |
| 12 (300) | W | W | W | NA | W | W | W | W | NA |
| 14 (350) Reducer only | W | W | W | W | W | W | W | W | W |

C Nickel alloy collar and 316 SST lap flange (Table 16). If weld neck flange is required, contact an Emerson Flow representative (see back page).

W Nickel alloy weld neck flange (Table 16).

NA Not Available.

All reducer models with nickel alloy materials of construction, all quad transmitter models, and all other listed flange rating codes use weld neck flanges.

Table 16: Flange illustrations

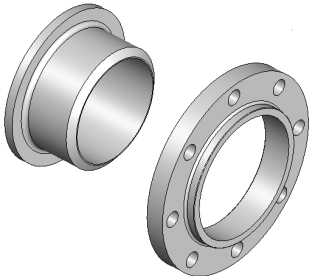
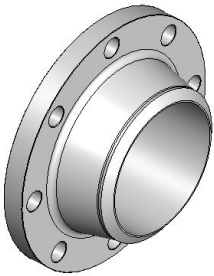
| Nickel alloy collar and 316 SST lap flange | Nickel alloy weld neck flange |
|---|---|
|  |  |

Non-wetted components

Table 17: Non-wetted materials by component

| Non-wetted Materials | |
|--------------------------|---------------------------|
| Sensor | 316 SST or Monel / Iconel |
| Lap Flange | 316 / 316 L SST |
| Type N Thermocouple | 304 Stainless Steel |
| Transmitter support tube | 316 Stainless Steel |

Table 17: Non-wetted materials by component (continued)

| Non-wetted Materials | |
|----------------------|---------------------------------|
| Transmitter housing | Aluminum or 316 Stainless Steel |

Surface finish

- Standard surface facing finish meets the requirements of the applicable flange standard.
- Optional smooth facing finish (flange option codes Cx) is 63 to 125 μ inches (1.6 to 3.1 μ meters) Ra roughness.

NACE compliance

- Materials of Construction meet NACE material recommendations per MR0175 / ISO15156 for use in H₂S containing environments in oil field production.
- Materials of Construction also meet NACE recommendations per MR0103-2003 for corrosive petroleum refining environments.
- MR0175/MR0103 compliance requires Q25 option in model code.

Armored cable glands

The cable gland material will match the material of construction of the mating parts at both the meter body end and transmitter end. The cable gland that connects to the meter body will utilize a stainless steel gland and the cable gland material at the electronics end will be either aluminum or stainless steel depending on the material of the electronics housing that is ordered.

Performance specifications

The following performance specifications are for all Rosemount models except where noted. Digital performance specifications applicable to both Digital HART and FOUNDATION Fieldbus output. Unless stated otherwise, all accuracy specifications include linearity, hysteresis, and repeatability.

Volume flow accuracy**Table 18: Volume flow accuracy**

| Process fluid | Digital and pulse output |
|---|---|
| Liquids with Reynolds number over 20,000 | $\pm 0.65\%$ of rate ⁽¹⁾⁽²⁾ |
| Gas and steam with Reynolds number over 15,000 | $\pm 1.0\%$ of rate ⁽³⁾⁽²⁾ |
| For all process fluids from stated limit to a Reynolds number of 10,000 | From process limit specification to $\pm 2\%$ linear increase |
| For Reynolds numbers less than 10,000 to 5,000 | $\pm 2\%$ to $\pm 6\%$, linear |

(1) 6 inch to 12 inch reducer (150 mm to 300 mm) $\pm 1.0\%$ of rate.

(2) Analog $\pm 0.025\%$ of span

(3) 6 inch to 12 inch reducer (150 mm to 300 mm): $\pm 1.35\%$ of rate.

Accuracy limitations for gas and steam:

- For ½ inch and 1 inch (DN 15 and DN 25); max velocity of 220 ft/s (67.06 m/s)
- For all dual shedder bar design meters: max velocity of 100 ft/s (30.5 m/s)
- For dual shedder bar design meters above 100 ft/s (30.5 m/s) contact an Emerson Flow representative (see back page).

Volume flow repeatability

± 0.1 percent of actual flow rate.

Stability

$\pm 0.1\%$ of rate over one year

Process temperature accuracy

Table 19: Process temperature accuracy by installation type

| Installation type | Process temperature accuracy |
|-------------------|---|
| Integral mount | 2.2 °F (1.2 °C) or 0.4% of reading, whichever is greater |
| Remote mount | Add ±0.018 °F/ft (±0.03 °C/m) of uncertainty to measurement |

Temperature sensor accuracy meets ASTM E230/E230M-17 Special Tolerance Standard.

Mass flow accuracy

Table 20: Mass flow accuracy by process fluid type

| Process fluid type | MV option code | Compensation type | Accuracy 8800DF 8800DR < 6" | Accuracy 8800DR 6" ≥ |
|-----------------------|----------------|--|--|--|
| Steam | MTA or MCA | Temperature compensation ⁽¹⁾ | ±2.0% of rate (typical) | ±2.20% of rate (typical) |
| | MPA and MCA | Pressure compensation ⁽¹⁾⁽²⁾⁽³⁾ | ±1.3% of rate at 30 psia through 2,000 psia | ±1.59% of rate at 30 psia through 2,000 psia |
| | MCA | Pressure and Temperature Compensation ⁽¹⁾⁽²⁾⁽³⁾ | ±1.2% of rate at 150 psia ±1.3% of rate at 300 psia ±1.6% of rate at 800 psia ±2.5% of rate at 2,000 psia | ±1.50% of rate at 150 psia ±1.59% of rate at 300 psia ±1.84% of rate at 800 psia ±2.66% of rate at 2,000 psia |
| Liquid (water) | MTA and MCA | Temperature Compensation | ±0.70% of rate up to 500 °F (260 °C) ⁽⁴⁾ | ±1.03% of rate up to 500 °F (260 °C) ⁽⁵⁾ |
| Liquid (user-defined) | MTA and MCA | Temperature Compensation | Dependent on user input | Dependent on user input |

- (1) Temperature range +176 °F to +842 °F (+80 °C to +450 °C)
- (2) Pressure measurement accuracy is ±0.1% of span.
- (3) Consult factory accuracy for < 30 psia and > 2,000 psia.
- (4) ±0.85% of rate between +500 °F to +600 °F (+260 °C to +316 °C)
- (5) ±1.14% of rate between +500 °F to +600 °F (+260 °C to +316 °C)

Process temperature effect on K-factor

The compensated K-factor is based on the reference K-factor as compensated for the given fixed process temperature and wetted materials. Compensated K-factor is calculated by the electronics.

The percentage change in K-factor for all materials is no greater than ±0.3 per 100 °F (56 °C).

Table 21: Ambient temperature effect

| Output type | Ambient temperature effect |
|--------------------------|--|
| Digital and pulse output | No effect |
| Analog output | ±0.1% of span from -58 °F to 185 °F (-50 to 85 °C) |

Measurable flow rates

Capable of processing signals from flow applications which meet the Reynolds number and velocity limitations listed in [Table 22](#), [Table 23](#), and [Table 24](#).

Table 22: Minimum Measurable Meter Reynolds Numbers

| Meter sizes | Reynolds number limitations |
|-----------------------------|-----------------------------|
| ½ – 4 inch (DN 15 – DN100) | 5000 minimum |
| 6 – 12 inch (DN150 – DN300) | |

Table 23: Minimum measurable meter velocities

| Process | Feet per second ⁽¹⁾ | Meters per second ⁽¹⁾ |
|------------------------|--------------------------------|----------------------------------|
| Liquids ⁽²⁾ | $\sqrt{36/\rho}$ | $\sqrt{54/\rho}$ |
| Gases ⁽²⁾ | $\sqrt{36/\rho}$ | $\sqrt{54/\rho}$ |

ρ is the process fluid density at flowing conditions in lb/ft³ for ft/s and kg/m³ for m/s.

(1) Referenced to schedule 40 pipe.

(2) This minimum measurable meter velocity is based on default filter settings.

Table 24: Maximum Measurable Meter Velocities (use the smaller of the two values)

| Process | Feet per second ⁽¹⁾ | | Meters per second ⁽¹⁾ | |
|----------------------|--------------------------------|--------|----------------------------------|---------|
| Liquids | $\sqrt{90,000/\rho}$ | or 30 | $\sqrt{134,000/\rho}$ | or 9.14 |
| Gases ⁽²⁾ | $\sqrt{90,000/\rho}$ | or 300 | $\sqrt{134,000/\rho}$ | or 91.4 |

ρ is the process fluid density at flowing conditions in lb/ft³ for ft/s and kg/m³ for m/s.

(1) Referenced to schedule 40 pipe.

(2) Accuracy limitations for gas and steam for dual-style meters (½ to 4 inch): max velocity of 100 ft/s (30.5 m/s).

Note

Sizing calculations are required to select the proper flow meter size. These calculations provide pressure loss, accuracy, minimum and maximum flow rate data to guide in proper selection. Vortex sizing software can be found using the Selection and Sizing tool. The Selection and Sizing tool can be accessed online or downloaded for offline use using this link:

www.Emerson.com/FlowSizing

Permanent pressure loss

The approximate permanent pressure loss (PPL) from the flowmeter is calculated for each application in the Vortex sizing software. Go to the [Rosemount 8800D Product Page](#), and select **Size** for detailed sizing on most applications, or complete a [Configuration Data Sheet](#) and contact an Emerson Flow representative (see back page).

The PPL is determined using the equation:

| $PPL = \frac{A \times \rho_f \times Q^2}{D^4}$ | <p>PPL Permanent pressure loss (psi or kPa)</p> <p>ρ_f Density at operating conditions (lb/ft³ or kg/m³)</p> <p>Q Actual volumetric flow rate (Gas = ft³/min or m³/hr; Liquid = gal/min or l/min)</p> <p>D Flowmeter bore diameter (in. or mm)</p> <p>A Constant depending on meter style, fluid type, and flow units. Determined per:</p> <table border="1" style="margin-left: 20px;"> <thead> <tr> <th rowspan="2">Meter style</th> <th colspan="2">English units</th> <th colspan="2">SI units</th> </tr> <tr> <th>A_{liquid}</th> <th>A_{gas}</th> <th>A_{liquid}</th> <th>A_{gas}</th> </tr> </thead> <tbody> <tr> <td>8800DF/W</td> <td>3.4 × 10⁻⁵</td> <td>1.9 × 10⁻³</td> <td>0.425</td> <td>118</td> </tr> <tr> <td>8800DR</td> <td>3.91 × 10⁻⁵</td> <td>2.19 × 10⁻³</td> <td>0.489</td> <td>136</td> </tr> <tr> <td>8800DD</td> <td>6.12 × 10⁻⁵</td> <td>3.42 × 10⁻³</td> <td>0.765</td> <td>212</td> </tr> <tr> <td>8800DQ</td> <td>6.12 × 10⁻⁵</td> <td>3.42 × 10⁻³</td> <td>0.765</td> <td>212</td> </tr> </tbody> </table> | Meter style | English units | | SI units | | A _{liquid} | A _{gas} | A _{liquid} | A _{gas} | 8800DF/W | 3.4 × 10 ⁻⁵ | 1.9 × 10 ⁻³ | 0.425 | 118 | 8800DR | 3.91 × 10 ⁻⁵ | 2.19 × 10 ⁻³ | 0.489 | 136 | 8800DD | 6.12 × 10 ⁻⁵ | 3.42 × 10 ⁻³ | 0.765 | 212 | 8800DQ | 6.12 × 10 ⁻⁵ | 3.42 × 10 ⁻³ | 0.765 | 212 |
|--|--|-------------------------|---------------------|------------------|----------|--|---------------------|------------------|---------------------|------------------|----------|------------------------|------------------------|-------|-----|--------|-------------------------|-------------------------|-------|-----|--------|-------------------------|-------------------------|-------|-----|--------|-------------------------|-------------------------|-------|-----|
| Meter style | English units | | SI units | | | | | | | | | | | | | | | | | | | | | | | | | | | |
| | A _{liquid} | A _{gas} | A _{liquid} | A _{gas} | | | | | | | | | | | | | | | | | | | | | | | | | | |
| 8800DF/W | 3.4 × 10 ⁻⁵ | 1.9 × 10 ⁻³ | 0.425 | 118 | | | | | | | | | | | | | | | | | | | | | | | | | | |
| 8800DR | 3.91 × 10 ⁻⁵ | 2.19 × 10 ⁻³ | 0.489 | 136 | | | | | | | | | | | | | | | | | | | | | | | | | | |
| 8800DD | 6.12 × 10 ⁻⁵ | 3.42 × 10 ⁻³ | 0.765 | 212 | | | | | | | | | | | | | | | | | | | | | | | | | | |
| 8800DQ | 6.12 × 10 ⁻⁵ | 3.42 × 10 ⁻³ | 0.765 | 212 | | | | | | | | | | | | | | | | | | | | | | | | | | |

Minimum upstream pressure (liquids)

Flow metering conditions that would allow cavitation, the release of vapor from a liquid, should be avoided. This flow condition can be avoided by remaining within the proper flow range of the meter and by following appropriate system design.

For some liquid applications, incorporation of a back pressure valve should be considered. To prevent cavitation, the minimum upstream pressure should be the smaller result of these two equations:

- $2.9 \times \Delta P + 1.3 \times p_v$
- $2.9 \times \Delta P + p_v + 0.5 \text{ psia (3.45 kPa)}$

Where:

- P** Line pressure five pipe diameters downstream of the meter (psia or kPa abs)
- ΔP** Pressure loss across the meter (psi or kPa)
- p_v** Liquid vapor pressure at operating conditions (psia or kPa abs)

Vibration effect

High vibration may cause a false flow measurement when there is no flow. The meter design will minimize this effect, and the factory settings for signal processing are selected to eliminate these errors for most applications. If an output error at zero flow is still detected, it can be eliminated by adjusting the low flow cutoff, trigger level, or low-pass filter. As the process begins to flow through the meter, most vibration effects are quickly overcome by the flow signal.

Vibration specifications

- Integral aluminum housings, remote aluminum housings, and remote SST housings: At or near the minimum liquid flow rate in a normal pipe mounted installation, the maximum vibration should be 0.087 inch (2,21 mm) double amplitude displacement or 1 g acceleration, whichever is smaller. At or near the minimum gas flow rate in a normal pipe mounted installation, the maximum vibration should be 0.043 inch (1,09 mm) double amplitude displacement or ½ g acceleration, whichever is smaller.
- Integral SST housing: At or near the minimum liquid flow rate in a normal pipe mounted installation, the maximum vibration should be 0.044 inch (1,11 mm) double amplitude displacement or ⅓ g acceleration, whichever is smaller. At or near the minimum gas flow rate in a normal pipe mounted installation, the maximum vibration should be 0.022 inch (0,55 mm) double amplitude displacement or ⅙ g acceleration, whichever is smaller.

Mounting position effect

Meter will meet accuracy specifications when mounted in horizontal, vertical, or inclined pipelines. Best practice for mounting in a horizontal pipe is to orient the shedder bar in the horizontal plane. This will prevent solids in liquid applications and liquid in gas/steam applications from disrupting the shedding frequency.

Pipe length requirements

Rated accuracy is based on the number of pipe diameters from an upstream disturbance. No K-factor correction is required if the meter is installed with 35D upstream and 5D downstream. The value of the K-factor may shift up to 0.5% when the upstream straight pipe length is reduced down to the minimum recommended 10D. Refer to the Rosemount 8800 Vortex Installation Effects Technical Data Sheet for detailed information on K-factor correction.

Flow calibration information

Flowmeter calibration and configuration information is provided with every flowmeter. For a certified copy of flow calibration data, the Q4 option code must be ordered in the model number.

Transient protection

The optional transient terminal block prevents damage to the flowmeter from transients induced by lightning, welding, heavy electrical equipment, or switch gears. The transient protection electronics are located in the terminal block.

The transient terminal block meets the following specifications:

- IEEE C62.41 - 2002 Category B
- 3 kA crest (8 × 20 ms)
- 6 kV crest (1.2 × 50 ms)
- 6 kV/0.5 kA (0.5 ms, 100 kHz, ring wave)

HART specifications

Output signals

| | |
|---------------------------------------|---|
| Digital HART signal | Bell 202 superimposed on 4–20 mA signal |
| Optional scalable pulse output | 0 to 10000 Hz; transistor switch closure with adjustable scaling via HART communications; capable of switching from 5 to 30 Vdc, 120 mA maximum |

Analog output adjustment

Engineering units and lower and upper range values are user-selected. Output is automatically scaled to provide 4 mA at the selected lower range value, 20 mA at the selected upper range value. No frequency input is required to adjust the range values.

Scalable frequency adjustment

The scalable pulse output can be set to a specific velocity, volume, or mass (i.e. 1 pulse = 1 lb). The scalable pulse output can also be scaled to a specific rate of volume, mass, or velocity (i.e. 100 Hz = 500 lb/hr).

Analog 4–20 mA Power supply

External power supply required. Each transmitter operates on 10.8 VDC to 42 VDC terminal voltage. See [Figure 4](#).

Power consumption

One watt maximum per transmitter.

HART communication

Figure 4: HART communication voltage/resistance requirement

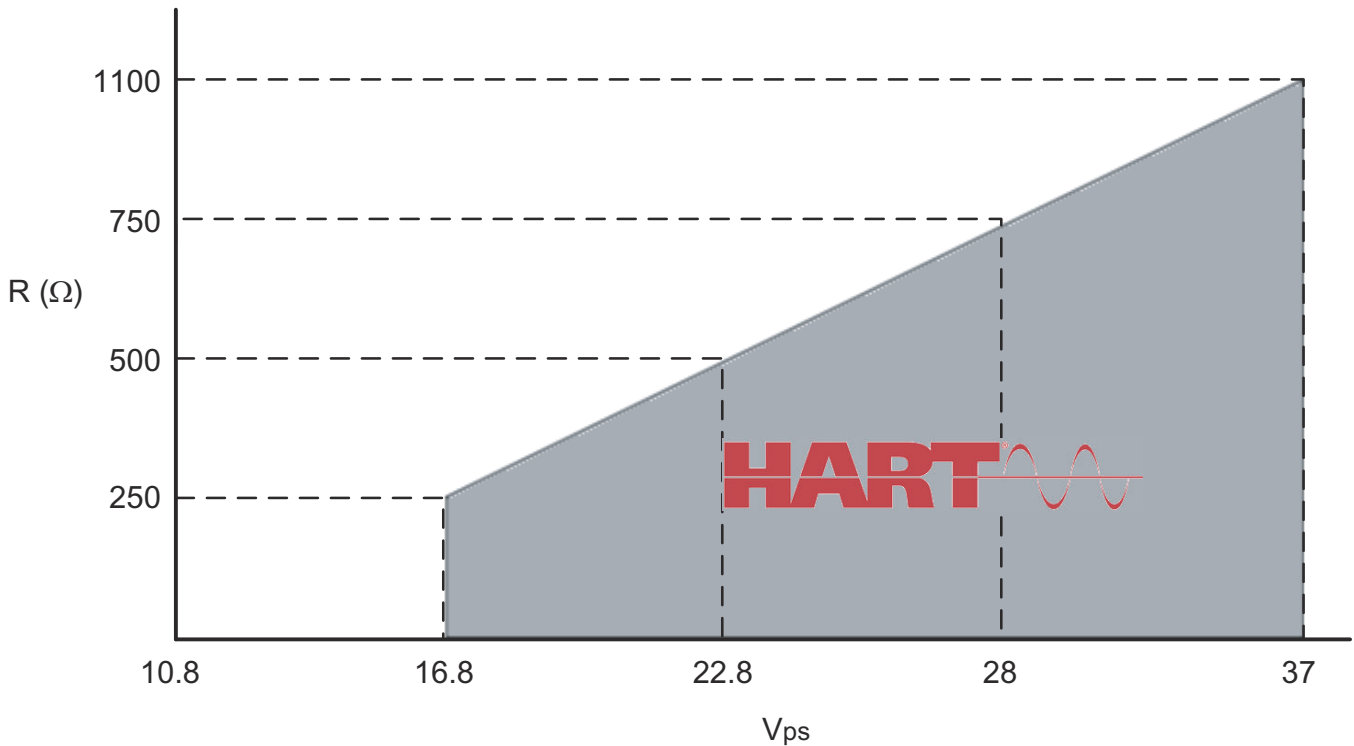

Maximum loop resistance is determined by the voltage level of the external power supply, as described in the graph. Note that HART Communication requires a minimum loop resistance of 250 ohms up to a maximum of 1100 ohms.

- R(Ω)** Load resistor value.
- V_{ps}** Minimum power supply voltage required

$$R(\Omega)_{\max} = 41.7 (V_{ps} - 10.8 \text{ V}).$$

Failure mode alarm levels

If transmitter self-diagnostics detect a fault condition, the analog signal will be driven to the values in [Table 25](#).

Table 25: mA outputs for low and high alarm

| Alarm jumper position | mA output by Alarm Type setting ⁽¹⁾ | |
|-----------------------|--|-----------------|
| | Rosemount standard | NAMUR-compliant |
| Low | 3.75 | 3.60 |
| Hi | 21.75 | 22.6 |

⁽¹⁾ The Alarm and Saturation Type settings can be pre-configured at the factory (Options C4 and CN for NAMUR-compliance) or user-configured.

Saturation output values

When the operating flow is outside the range points, the analog output continues to track the operating flow until reaching the saturation values in [Table 26](#). The output does not exceed the listed saturation value regardless of the operating flow.

Table 26: mA output saturation values

| | mA output saturation value by type ⁽¹⁾ | |
|-----|---|-----------------|
| | Rosemount standard | NAMUR-Compliant |
| Low | 3.9 | 3.8 |
| Hi | 20.8 | 20.5 |

(1) The Alarm and Saturation Type settings can be pre-configured at the factory (Options C4 and CN for NAMUR-compliance) or user-specified.

Damping

Flow Damping adjustable between 0.2 and 255 seconds.

Process temperature damping adjustable between 0.4 and 32.0 seconds (MTA/MCA Option only).

Response time

Three vortex shedding cycles or 300 ms, whichever is greater, maximum required to reach 63.2% of actual input with the minimum damping (0.2 seconds).

Turn-on time

Less than six seconds plus the response time to rated accuracy from power up (less than eight seconds with the MTA/MCA Option).

Security lockout

When the security lockout jumper is enabled, the electronics will not allow you to modify parameters that affect flowmeter output.

Output testing

Analog output Flow meter may be commanded to set the analog output to a specified value between 3.6 mA and 22.6 mA.

Pulse output Flow meter may be commanded to set the pulse output frequency to a specified value between 0 Hz and 10000 Hz.

Low flow cutoff

Optimized at the factory per the user's process conditions per Rosemount 8800D Configuration Data Sheet (00806-0100-4004) and typically required no adjustment. In certain cases, if required, it can be further adjusted after installation. Below selected value, output is driven to 4 mA and zero pulse output frequency.

Overrange capability

Analog signal output continues to 105 percent of span for Standard limits (or 103.1% for NAMUR), then remains constant with increasing flow. The digital and pulse outputs will continue to indicate flow up to the upper sensor limit of the flowmeter and a maximum pulse output frequency of 10400 Hz.

Magnetic-field interference

- Output error less than $\pm 0.025\%$ of span at 30 A/m (rms).
- Tested per EN 61326.

Note

During a surge event, devices with 4–20 mA (Outputs option codes D and P) or Modbus output (Output option code M) may exceed maximum EMC deviation limit or reset; however, device will self-recover and return to normal operation within specified start-up time.

Series mode noise rejection

Output error less than $\pm 0.025\%$ of span at 1 V rms, 60 Hz.

Common mode noise rejection

Output error less than $\pm 0.025\%$ of span at 30 V rms, 60 Hz.

Power supply effect

Less than 0.005% of span per volt

Transmitter electrical connections

| Model | Terminal type |
|-----------------------------|---|
| Analog 4–20 mA/HART | Compression screw terminal permanently fixed to the terminal block. |
| Analog 4–20 mA/HART + Pulse | |

Field Communicator connections

| Communication and test terminals | |
|----------------------------------|---|
| All models | Clip connections permanently fixed to the terminal block. |

The transmitter test function permits testing the loop output current without disconnecting the loop power.

FOUNDATION™ Fieldbus specifications

Transducer block

The transducer block calculates flow from sensor frequency. The calculation includes information about damping, shedding frequency, K-factor, process fluid, pipe ID, and diagnostics.

Resource block

The resource block contains physical transmitter information, including available memory, manufacturer identification, device type, software tag, and unique identification.

Backup Link Active Scheduler (LAS)

The transmitter is classified as a device link master. A device link master can function as an LAS if the current link master device fails or is removed from the segment.

The host or other configuration tool is used to download the schedule for the application to the link master device. In the absence of a primary link master, the transmitter will claim the LAS and provide permanent control for the H1 segment.

Diagnostics

The transmitter automatically performs continuous self-diagnostics. The user can perform on-line testing of the transmitter digital signal. Advanced simulation diagnostics are available. This enables remote verification of the electronics via a flow signal generator built into the electronics. The sensor strength value can be used to view the process flow signal and provide information regarding filter settings.

FOUNDATION Fieldbus function blocks

- Analog input** The AI function block processes the measurement and makes it available to other function blocks. The AI function block also allows filtering, alarming, and engineering unit changes.

The Rosemount 8800D Flowmeter with Foundation Fieldbus comes with five AI function blocks. Two of the AI function blocks, flow and signal strength, come as standard. Three additional AI function blocks are available when the MTA option is selected: electronics temperature, process temperature, and process density. Note that process density is only available when the process fluid is configured as temperature compensated saturated steam, shown as TComp Sat Steam in the device.
- Proportional/Integral/Derivative** The optional PID function block provides a sophisticated implementation of the universal PID algorithm. The PID function block features input for feed forward control, alarms on the process variable, and control deviation. The PID type (series or Instrument Society of America [ISA]) is user-selectable on the derivative filter.
- Integrator** The standard integrator block is available for totalization of flow.

Arithmetic The standard arithmetic block is available for various computations.

Output signal

Completely digital output with Foundation Fieldbus communication (ITK 6.0 compliant).

Power supply

External power supply required. Flowmeter operates on 9 to 32 Vdc, 18 mA maximum.

Power consumption

600 mW maximum

Failure mode alarm

The AI block allows the user to configure the alarm to HI-HI, HI, LO, or LO-LO with a variety of priority levels.

Damping

Flow Damping adjustable between 0.2 and 255 seconds.

Process temperature damping adjustable between 0.4 and 32.0 seconds (MTA Option only).

Response time

Three vortex shedding cycles or 300 ms, whichever is greater, maximum required to reach 63.2% of actual input with the minimum damping (0.2 seconds).

Turn-on time

Performance within specifications no greater than 10.0 seconds after power is applied.

Overrange capability

- For liquid process fluid type, the transducer block digital output will continue to a nominal value of 25 ft/s. After that, the status associated with the transducer block output will go to UNCERTAIN. Above a nominal value of 30 ft/s, the status will go to BAD.
- For gas/steam service, the transducer block digital output will continue to a nominal value of 220 ft/s for 0.5 and 1.0-in. line sizes and a nominal value of 250 ft/s for 1.5–12-in. line sizes. After that, the status associated with the transducer block output will go to UNCERTAIN. Above a nominal value of 300 ft/s for all line sizes, the status will go to BAD.

Status

If self-diagnostics detect a transmitter failure, the status of the measurement will inform the control system. Status may also set the PID output to a safe value.

Schedule entries

Six (6)

Links

Twelve (12)

Virtual communications relationships (VCRs)

- Maximum VCRs: 20
- Number of Permanent Entries: 1

Table 27: Block Information

| Block | Base index | Execution time (milliseconds) |
|-----------------------|------------|-------------------------------|
| Resource (RB) | 1000 | N/A |
| Transducer (TB) | 1200 | N/A |
| Analog Input 1 (AI 1) | 1400 | 15 |
| Analog Input 2 (AI 2) | 1600 | 15 |

Table 27: Block Information (continued)

| Block | Base index | Execution time (milliseconds) |
|--|------------|-------------------------------|
| Proportional/ Integral/ Derivative (PID) | 1800 | 20 |
| Integrator (INTEG) | 2000 | 25 |
| Arithmetic (ARITH) | 2200 | 20 |
| Analog Input 3 (AI 3) | 2400 | 15 |
| Analog Input 4 (AI 4) | 2600 | 15 |
| Analog Input 5 (AI 5) | 2800 | 15 |

Magnetic-field interference

- No effect on digital output accuracy at 30 A/m (rms).
- Tested per EN 61326.

Series mode noise rejection

No effect on digital output accuracy at 1 V rms, 60 Hz.

Common mode noise rejection

No effect on digital output accuracy at 250 V rms, 60 Hz.

Power supply effect

No effect on accuracy.

Electrical connections

| Model | Power terminals |
|---------------------|---|
| FOUNDATION fieldbus | Compression screw terminal permanently fixed to the terminal block. |

Modbus RS-485 specifications

Modbus output is provided by a HART to Modbus output conversion.

Output signals

The Rosemount 8800 communicates via Modbus (RS-485) providing device status and 4 dynamic variables. Communication uses 1 start bit and 8 data bits. Baud rates supported are 1200, 2400, 4800, 9600, 19200, and 38400. One or two stop bits, and either none, odd, or even parity are available. All byte orders are supported.

Configuration

Configuration is only available through the HART communication port. No configuration is performed through Modbus.

Alarm handling

The output from the Modbus transmitter in case of an error (such as a field device malfunction) can be configured. The values for Modbus registers corresponding to PV, SV, TV, and QV will be changed accordingly (applicable registers in area 1300, 2000, 2100, and 2200).

Power supply

External power supply required. Each transmitter operates on 10 VDC to 30 VDC terminal voltage.

Scalable pulse output (for temporary testing only)

0 to 10000 Hz; transistor switch closure with adjustable scaling via HART communications; capable of switching from 5 to 30 Vdc, 120 mA maximum. The scalable pulse output can be set to a specific velocity, volume, or mass (i.e. 1 pulse = 1 lb). The scalable pulse output can also be scaled to a specific rate of volume, mass, or velocity (i.e. 100 Hz = 500 lb/hr).

LCD indicator functional specifications

Optional LCD indicator

The optional 11 digit, two-decimal, two-line integral LCD display can be configured to alternate between selected display options, which differ depending upon the output type selected.

Figure 5: Examples

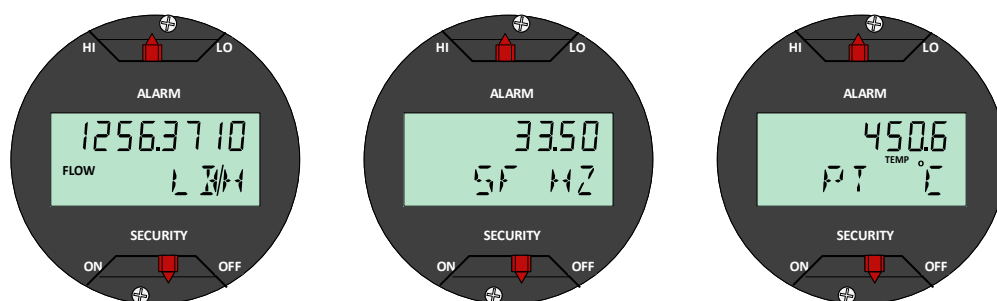

When more than one item is selected, the display will scroll through all items selected. In the event of a fault, the display shows the applicable fault code.

Indicator options for models with HART or Modbus protocol

- Primary Variable
- Velocity Flow
- Volumetric Flow
- Corrected Volumetric Flow
- Mass Flow
- Signal Strength
- Percent of Range
- Analog Output
- Totalizer
- Shedding Frequency
- Pulse Output Frequency
- Electronics Temperature
- Process Temperature (MTA/MCA only)
- Process Pressure (MPA/MCA only)
- Calculated Process Density (MTA/MCA/MPA only)
- Elapsed Time Meter (ETM)

Indicator options for models with FOUNDATION™ fieldbus protocol

- Primary Variable

- Percent of Range
- Shedding Frequency
- Electronics Temperature (MTA only)
- Process Temperature (MTA only)
- Calculated Process Density (MTA only)
- Totalizer (via Integrator block)

Quality certificate details

Table 28: Weld examination certifications for Q70, Q71

| | | | Helium report | Dye pen report | Radio-graphic report | CD of images |
|--|------------|------------|---------------|----------------|----------------------|--------------|
| 8800DF/8800DD/8800DQ Form Q70, Inspection Certificate Weld Examination, ISO 10747.3.1 | | | | | | |
| | 0.5 inch | 15 mm | ✓ | | ✓ | |
| | 1–4 inch | 25–100 mm | | | ✓ | |
| | 6–12 inch | 150–300 mm | | ✓ | ✓ | |
| 8800DF/8800DD/8800DQ Form Q71, Inspection Certificate Weld Examination, ISO 10747.3.1 | | | | | | |
| | 0.5 inch | 15 mm | ✓ | | ✓ | ✓ |
| | 1–4 inch | 25–100 mm | | | ✓ | ✓ |
| | 6–12 inch | 150–300 mm | | ✓ | ✓ | ✓ |
| 8800DR Form Q70, Inspection Certificate Weld Examination, ISO 10747.3.1 | | | | | | |
| | 1 inch | 25 mm | ✓ | | ✓ | |
| | 1.5–6 inch | 40–150 mm | | | ✓ | |
| | 8–12 inch | 200–300 mm | | ✓ | ✓ | |
| 8800DR Form Q71, Inspection Certificate Weld Examination, ISO 10747.3.1 | | | | | | |
| | 1 inch | 25 mm | ✓ | | ✓ | ✓ |
| | 1.5–6 inch | 40–150 mm | | | ✓ | ✓ |
| | 8–12 inch | 200–300 mm | | ✓ | ✓ | ✓ |
| 8800DW Form Q70, Inspection Certificate Weld Examination, ISO 10747.3.1 | | | | | | |
| | 0.5 inch | 15 mm | ✓ | | | |
| | 6–8 inch | 150–200 mm | | ✓ | | |
| 8800DW Form Q71, Inspection Certificate Weld Examination, ISO 10747.3.1 | | | | | | |
| | 0.5 inch | 15 mm | ✓ | | | |
| | 6–8 inch | 150–200 mm | | ✓ | | |

Table 29: PMI Code Q76 for X-Ray Fluorescent Spectrometry (XFR)

| Alloy | Elements to be identified |
|---------------------------|---|
| 316L Stainless Steel | Cr (Chromium), Ni (Nickel), Mo (Molybdenum) |
| NiB (Nickel based) Alloys | Cr (Chromium), Ni (Nickel), Mo (Molybdenum) |
| 25Cr Super Duplex | Cr (Chromium), Ni (Nickel), Mo (Molybdenum) |

Table 30: PMI Code Q77 for Optical Emission Spark Spectrometry (OES)

| Alloy | Elements to be identified |
|----------------------|---|
| 316L Stainless Steel | Cr (Chromium), Ni (Nickel), Mo (Molybdenum), C (Carbon) |
| Carbon Steel | Cr (Chromium), Ni (Nickel), Mo (Molybdenum), C (Carbon) |

Typical flow rates

This section provides typical flow ranges for some common process fluids with default filter settings. Consult an Emerson representative (see back page) to obtain a computer sizing program that describes in greater detail the flow range for an application.

Table 31 is a reference of pipe velocities that can be measured for the standard Rosemount 8800D and the reducer Rosemount 8800DR Vortex Meters. It does not consider density limitations, as described in Table 22 and Table 23. Velocities are referenced in schedule 40 pipe.

Table 31: Typical pipe velocity ranges for Rosemount 8800D and 8800DR

| Process line size (inches/ DN) | Vortex meter ⁽¹⁾ | Liquid velocity ranges | | Gas velocity ranges | |
|-----------------------------------|-----------------------------|------------------------|-------------|---------------------|--------------|
| | | (ft/s) | (m/s) | (ft/s) | (m/s) |
| 0.5/ 15 | 8800DF005 | 0.70 to 25.0 | 0.21 to 7.6 | 6.50 to 250.0 | 1.98 to 76.2 |
| 1/ 25 | 8800DF010 | 0.70 to 25.0 | 0.21 to 7.6 | 6.50 to 250.0 | 1.98 to 76.2 |
| | 8800DR010 | 0.25 to 8.8 | 0.08 to 2.7 | 2.29 to 87.9 | 0.70 to 26.8 |
| 1.5/ 40 | 8800DF015 | 0.70 to 25.0 | 0.21 to 7.6 | 6.50 to 250.0 | 1.98 to 76.2 |
| | 8800DR015 | 0.30 to 10.6 | 0.09 to 3.2 | 2.76 to 106.1 | 0.84 to 32.3 |
| 2/ 50 | 8800DF020 | 0.70 to 25.0 | 0.21 to 7.6 | 6.50 to 250.0 | 1.98 to 76.2 |
| | 8800DR020 | 0.42 to 15.2 | 0.13 to 4.6 | 3.94 to 151.7 | 1.20 to 46.2 |
| 3/ 80 | 8800DF030 | 0.70 to 25.0 | 0.21 to 7.6 | 6.50 to 250.0 | 1.98 to 76.2 |
| | 8800DR030 | 0.32 to 11.3 | 0.10 to 3.5 | 2.95 to 113.5 | 0.90 to 34.6 |
| 4/ 100 | 8800DF040 | 0.70 to 25.0 | 0.21 to 7.6 | 6.50 to 250.0 | 1.98 to 76.2 |
| | 8800DR040 | 0.41 to 14.5 | 0.12 to 4.4 | 3.77 to 145.2 | 1.15 to 44.3 |
| 6/ 150 | 8800DF060 | 0.70 to 25.0 | 0.21 to 7.6 | 6.50 to 250.0 | 1.98 to 76.2 |
| | 8800DR060 | 0.31 to 11.0 | 0.09 to 3.4 | 2.86 to 110.2 | 0.87 to 33.6 |
| 8/ 200 | 8800DF080 | 0.70 to 25.0 | 0.21 to 7.6 | 6.50 to 250.0 | 1.98 to 76.2 |
| | 8800DR080 | 0.40 to 14.4 | 0.12 to 4.4 | 3.75 to 144.4 | 1.14 to 44.0 |
| 10/ 250 | 8800DF100 | 0.90 to 25.0 | 0.27 to 7.6 | 6.50 to 250.0 | 1.98 to 76.2 |
| | 8800DR100 | 0.44 to 15.9 | 0.13 to 4.8 | 4.12 to 158.6 | 1.26 to 48.3 |

Table 31: Typical pipe velocity ranges for Rosemount 8800D and 8800DR (continued)

| Process line size (inches/ DN) | Vortex meter ⁽¹⁾ | Liquid velocity ranges | | Gas velocity ranges | |
|-----------------------------------|-----------------------------|------------------------|-------------|---------------------|--------------|
| | | (ft/s) | (m/s) | (ft/s) | (m/s) |
| 12/ 300 | 8800DF120 | 1.10 to 25.0 | 0.34 to 7.6 | 6.50 to 250.0 | 1.98 to 76.2 |
| | 8800DR120 | 0.63 to 17.6 | 0.19 to 5.4 | 4.58 to 176.1 | 1.40 to 53.7 |

(1) Velocity range of the Rosemount 8800DW is the same as Rosemount 8800DF.

Note

Table 32 is a reference of flow rates that can be measured for the standard Rosemount 8800D and the reducer 8800DR Vortex Meters. It does not consider density limitations, as described in Table 22 and Table 23.

Table 32: Water flow rate limits for the Rosemount 8800D and 8800DR

| Process line size (inches/ DN) | Vortex meter ⁽¹⁾ | Minimum and maximum measurable water flow rates ⁽²⁾ | |
|-----------------------------------|-----------------------------|--|-------------------|
| | | Gallons/minute | Cubic meters/hour |
| 0.5/ 15 | 8800DF005 | 1.76 to 23.7 | 0.40 to 5.4 |
| 1/ 25 | 8800DF010 | 2.96 to 67.3 | 0.67 to 15.3 |
| | 8800DR010 | 1.76 to 23.7 | 0.40 to 5.4 |
| 1.5/ 40 | 8800DF015 | 4.83 to 158 | 1.10 to 35.9 |
| | 8800DR015 | 2.96 to 67.3 | 0.67 to 15.3 |
| 2/ 50 | 8800DF020 | 7.96 to 261 | 1.81 to 59.4 |
| | 8800DR020 | 4.83 to 158.0 | 1.10 to 35.9 |
| 3/ 80 | 8800DF030 | 17.5 to 576 | 4.00 to 130 |
| | 8800DR030 | 7.96 to 261.0 | 1.81 to 59.3 |
| 4/ 100 | 8800DF040 | 30.2 to 992 | 6.86 to 225 |
| | 8800DR040 | 17.5 to 576 | 4.00 to 130 |
| 6/ 150 | 8800DF060 | 68.5 to 2251 | 15.6 to 511 |
| | 8800DR060 | 30.2 to 992 | 6.86 to 225 |
| 8/ 200 | 8800DF080 | 119 to 3898 | 27.0 to 885 |
| | 8800DR080 | 68.5 to 2251 | 15.6 to 511 |
| 10/ 250 | 8800DF100 | 231 to 6144 | 52.2 to 1395 |
| | 8800DR100 | 119 to 3898 | 27.0 to 885 |
| 12/ 300 | 8800DF120 | 391 to 8813 | 88.8 to 2002 |
| | 8800DR120 | 231 to 6144 | 52.2 to 1395 |

(1) Velocity range of the 8800DW is the same as 8800DF.

(2) Conditions: 77 °F (25 °C) and 14.7 psia (1.01 bar absolute)

Table 33: Air flow rate limits at 59 °F (15 °C)

| Process pressure | Flow rate limits | Minimum and maximum air flow rates for line sizes 1/2-in./DN 15 through 1-in./DN 25 | | | | | | | |
|--------------------------|------------------|---|------|------------------|---------------|-----------------|------|------------------|------|
| | | 1/2-in./DN 15 | | | | 1-in./DN 25 | | | |
| | | Rosemount 8800D | | Rosemount 8800DR | | Rosemount 8800D | | Rosemount 8800DR | |
| | | ACFM | ACMH | ACFM | ACMH | ACFM | ACMH | ACFM | ACMH |
| 0 psig (0 bar G) | max | 27.9 | 47.3 | Not Available | Not Available | 79.2 | 134 | 27.9 | 47.3 |
| | min | 4.62 | 7.84 | | | 9.71 | 16.5 | 4.62 | 7.84 |
| 50 psig (3,45 bar G) | max | 27.9 | 47.3 | Not Available | Not Available | 79.2 | 134 | 27.9 | 47.3 |
| | min | 1.31 | 2.22 | | | 3.72 | 6.32 | 1.31 | 2.22 |
| 100 psig (6,89 bar G) | max | 27.9 | 47.3 | Not Available | Not Available | 79.2 | 134 | 27.9 | 47.3 |
| | min | 0.98 | 1.66 | | | 2.80 | 4.75 | 0.98 | 1.66 |
| 150 psig (10,3 bar G) | max | 27.9 | 47.3 | Not Available | Not Available | 79.2 | 134 | 27.9 | 47.3 |
| | min | 0.82 | 1.41 | | | 2.34 | 3.98 | 0.82 | 1.41 |
| 200 psig (13,8 bar G) | max | 27.9 | 47.3 | Not Available | Not Available | 79.2 | 134 | 27.9 | 47.3 |
| | min | 0.82 | 1.41 | | | 2.34 | 3.98 | 0.82 | 1.41 |
| 300 psig (20,7 bar G) | max | 27.9 | 47.3 | Not Available | Not Available | 79.2 | 134 | 27.9 | 47.3 |
| | min | 0.82 | 1.41 | | | 2.34 | 3.98 | 0.82 | 1.41 |
| 400 psig (27,6 bar G) | max | 25.7 | 43.9 | Not Available | Not Available | 73.0 | 124 | 25.7 | 43.9 |
| | min | 0.82 | 1.41 | | | 2.34 | 3.98 | 0.82 | 1.41 |
| 500 psig (34,5 bar G) | max | 23.0 | 39.4 | Not Available | Not Available | 66.0 | 112 | 23.0 | 39.4 |
| | min | 0.82 | 1.41 | | | 2.34 | 3.98 | 0.82 | 1.41 |

Table 34: Air flow rate limits at 59 °F (15 °C)

| Process pressure | Flow rate limits | Minimum and maximum air Flow rates for line sizes 1 1/2-in./DN 40 through 2-in./DN 50 | | | | | | | |
|--------------------------|------------------|---|------|------------------|------|-----------------|------|------------------|------|
| | | 1 1/2-in./DN 40 | | | | 2-in./DN 50 | | | |
| | | Rosemount 8800D | | Rosemount 8800DR | | Rosemount 8800D | | Rosemount 8800DR | |
| | | ACFM | ACMH | ACFM | ACMH | ACFM | ACMH | ACFM | ACMH |
| 0 psig (0 bar G) | max | 212 | 360 | 79.2 | 134 | 349 | 593 | 212 | 360 |
| | min | 18.4 | 31.2 | 9.71 | 16.5 | 30.3 | 51.5 | 18.4 | 31.2 |
| 50 psig (3,45 bar G) | max | 212 | 360 | 79.2 | 134 | 349 | 593 | 212 | 360 |
| | min | 8.76 | 14.9 | 3.72 | 6.32 | 14.5 | 24.6 | 8.76 | 14.9 |
| 100 psig (6,89 bar G) | max | 212 | 360 | 79.2 | 134 | 349 | 593 | 212 | 360 |
| | min | 6.58 | 11.2 | 2.80 | 4.75 | 10.8 | 18.3 | 6.58 | 11.2 |
| 150 psig (10,3 bar G) | max | 212 | 360 | 79.2 | 134 | 349 | 593 | 212 | 360 |
| | min | 5.51 | 9.36 | 2.34 | 3.98 | 9.09 | 15.4 | 5.51 | 9.36 |
| 200 psig (13,8 bar G) | max | 212 | 360 | 79.2 | 134 | 349 | 593 | 212 | 360 |
| | min | 5.51 | 9.36 | 2.34 | 3.98 | 9.09 | 15.4 | 5.51 | 9.36 |
| 300 psig (20,7 bar G) | max | 198 | 337 | 79.2 | 134 | 326 | 554 | 198 | 337 |
| | min | 5.51 | 9.36 | 2.34 | 3.98 | 9.09 | 15.4 | 5.51 | 9.36 |
| 400 psig (27,6 bar G) | max | 172 | 293 | 73.0 | 124 | 284 | 483 | 172 | 293 |
| | min | 5.51 | 9.36 | 2.34 | 3.98 | 9.09 | 15.4 | 5.51 | 9.36 |

Table 34: Air flow rate limits at 59 °F (15 °C) (continued)

| Process pressure | Flow rate limits | Minimum and maximum air Flow rates for line sizes 1 1/2-in./DN 40 through 2-in./DN 50 | | | | | | | |
|--------------------------|------------------|---|------|------------------|------|-----------------|------|------------------|------|
| | | 1 1/2-in./DN 40 | | | | 2-in./DN 50 | | | |
| | | Rosemount 8800D | | Rosemount 8800DR | | Rosemount 8800D | | Rosemount 8800DR | |
| | | ACFM | ACMH | ACFM | ACMH | ACFM | ACMH | ACFM | ACMH |
| 500 psig (34,5 bar G) | max | 154 | 262 | 66.0 | 112 | 254 | 432 | 154 | 262 |
| | min | 5.51 | 9.36 | 2.34 | 3.98 | 9.09 | 15.4 | 5.51 | 9.36 |

Table 35: Air flow rate limits at 59 °F (15 °C)

| Process pressure | Flow rate limits | Minimum and maximum air flow rates for line sizes 3-in./DN 80 through 4-in./DN 100 | | | | | | | |
|--------------------------|------------------|--|------|------------------|------|-----------------|------|------------------|------|
| | | 3-in./DN 80 | | | | 4-in./DN 100 | | | |
| | | Rosemount 8800D | | Rosemount 8800DR | | Rosemount 8800D | | Rosemount 8800DR | |
| | | ACFM | ACMH | ACFM | ACMH | ACFM | ACMH | ACFM | ACMH |
| 0 psig (0 bar G) | max | 770 | 1308 | 349 | 593 | 1326 | 2253 | 770 | 1308 |
| | min | 66.8 | 114 | 30.3 | 51.5 | 115 | 195 | 66.8 | 114 |
| 50 psig (3,45 bar G) | max | 770 | 1308 | 349 | 593 | 1326 | 2253 | 770 | 1308 |
| | min | 31.8 | 54.1 | 14.5 | 24.6 | 54.8 | 93.2 | 31.8 | 54.1 |
| 100 psig (6,89 bar G) | max | 770 | 1308 | 349 | 593 | 1326 | 2253 | 770 | 1308 |
| | min | 23.9 | 40.6 | 10.8 | 18.3 | 41.1 | 69.8 | 23.9 | 40.6 |
| 150 psig (10,3 bar G) | max | 770 | 1308 | 349 | 593 | 1326 | 2253 | 770 | 1308 |
| | min | 20.0 | 34.0 | 9.09 | 15.4 | 34.5 | 58.6 | 20.0 | 34.0 |
| 200 psig (13,8 bar G) | max | 770 | 1308 | 349 | 593 | 1326 | 2253 | 770 | 1308 |
| | min | 20.0 | 34.0 | 9.09 | 15.4 | 34.5 | 58.6 | 20.0 | 34.0 |
| 300 psig (20,7 bar G) | max | 718 | 1220 | 326 | 554 | 1237 | 2102 | 718 | 1220 |
| | min | 20.0 | 34.0 | 9.09 | 15.4 | 34.5 | 58.6 | 20.0 | 34.0 |
| 400 psig (27,6 bar G) | max | 625 | 1062 | 284 | 483 | 1076 | 1828 | 625 | 1062 |
| | min | 20.0 | 34.0 | 9.09 | 15.4 | 34.5 | 58.6 | 20.0 | 34.0 |
| 500 psig (34,5 bar G) | max | 560 | 951 | 254 | 432 | 964 | 1638 | 560 | 951 |
| | min | 20.0 | 34.0 | 9.09 | 15.4 | 34.5 | 58.6 | 20.0 | 34.0 |

Table 36: Air flow rate limits at 59 °F (15 °C)

| Process pressure | Flow rate limits | Minimum and maximum air flow rates for line sizes 6-in./DN 150 through 8-in./DN 200 | | | | | | | |
|--------------------------|------------------|---|------|------------------|------|-----------------|------|------------------|------|
| | | 6-in./DN 150 | | | | 8-in./DN 200 | | | |
| | | Rosemount 8800D | | Rosemount 8800DR | | Rosemount 8800D | | Rosemount 8800DR | |
| | | ACFM | ACMH | ACFM | ACMH | ACFM | ACMH | ACFM | ACMH |
| 0 psig (0 bar G) | max | 3009 | 5112 | 1326 | 2253 | 5211 | 8853 | 3009 | 5112 |
| | min | 261 | 443 | 115 | 195 | 452 | 768 | 261 | 443 |
| 50 psig (3,45 bar G) | max | 3009 | 5112 | 1326 | 2253 | 5211 | 8853 | 3009 | 5112 |
| | min | 124 | 211 | 54.8 | 93.2 | 215 | 365 | 124 | 211 |
| 100 psig (6,89 bar G) | max | 3009 | 5112 | 1326 | 2253 | 5211 | 8853 | 3009 | 5112 |
| | min | 93.3 | 159 | 41.1 | 69.8 | 162 | 276 | 93.3 | 159 |

Table 36: Air flow rate limits at 59 °F (15 °C) (continued)

| Process pressure | Flow rate limits | Minimum and maximum air flow rates for line sizes 6-in./DN 150 through 8-in./DN 200 | | | | | | | |
|--------------------------|------------------|---|------|------------------|------|-----------------|------|------------------|------|
| | | 6-in./DN 150 | | | | 8-in./DN 200 | | | |
| | | Rosemount 8800D | | Rosemount 8800DR | | Rosemount 8800D | | Rosemount 8800DR | |
| | | ACFM | ACMH | ACFM | ACMH | ACFM | ACMH | ACFM | ACMH |
| 150 psig (10,3 bar G) | max | 3009 | 5112 | 1326 | 2253 | 5211 | 8853 | 3009 | 5112 |
| | min | 78.2 | 133 | 34.5 | 58.6 | 135 | 229 | 78.2 | 133 |
| 200 psig (13,8 bar G) | max | 3009 | 5112 | 1326 | 2253 | 5211 | 8853 | 3009 | 5112 |
| | min | 78.2 | 133 | 34.5 | 58.6 | 135 | 229 | 78.2 | 133 |
| 300 psig (20,7 bar G) | max | 2807 | 4769 | 1237 | 2102 | 4862 | 8260 | 2807 | 4769 |
| | min | 78.2 | 133 | 34.5 | 58.6 | 135 | 229 | 78.2 | 133 |
| 400 psig (27,6 bar G) | max | 2442 | 4149 | 1076 | 1828 | 4228 | 7183 | 2442 | 4149 |
| | min | 78.2 | 133 | 34.5 | 58.6 | 136 | 229 | 78.2 | 133 |
| 500 psig (34,5 bar G) | max | 2188 | 3717 | 964 | 1638 | 3789 | 6437 | 2188 | 3717 |
| | min | 78.2 | 133 | 34.5 | 58.6 | 136 | 229 | 78.2 | 133 |

Table 37: Saturated steam flow rate limits (assumes steam quality is 100%)

| Process pressure | Flow rate limits | Minimum and maximum saturated steam flow rates for line sizes 1/2-in./DN 15 through 1-in./DN 25 | | | | | | | |
|--------------------------|------------------|---|-------|------------------|---------------|-----------------|-------|------------------|-------|
| | | 1/2-in./DN 15 | | | | 1-in./DN 25 | | | |
| | | Rosemount 8800D | | Rosemount 8800DR | | Rosemount 8800D | | Rosemount 8800DR | |
| | | lb/hr | kg/hr | lb/hr | kg/hr | lb/hr | kg/hr | lb/hr | kg/hr |
| 15 psig (1,03 bar G) | max | 120 | 54.6 | Not Available | Not Available | 342 | 155 | 120 | 54.6 |
| | min | 12.8 | 5.81 | Available | Available | 34.8 | 15.8 | 12.8 | 5.81 |
| 25 psig (1,72 bar G) | max | 158 | 71.7 | Not Available | Not Available | 449 | 203 | 158 | 71.7 |
| | min | 14.0 | 6.35 | Available | Available | 39.9 | 18.1 | 14.0 | 6.35 |
| 50 psig (3,45 bar G) | max | 250 | 113 | Not Available | Not Available | 711 | 322 | 250 | 113 |
| | min | 17.6 | 8.00 | Available | Available | 50.1 | 22.7 | 17.6 | 8.00 |
| 100 psig (6,89 bar G) | max | 429 | 194 | Not Available | Not Available | 1221 | 554 | 429 | 194 |
| | min | 23.1 | 10.5 | Available | Available | 65.7 | 29.8 | 23.1 | 10.5 |
| 150 psig (10,3 bar G) | max | 606 | 275 | Not Available | Not Available | 1724 | 782 | 606 | 275 |
| | min | 27.4 | 12.5 | Available | Available | 78.1 | 35.4 | 27.4 | 12.5 |
| 200 psig (13,8 bar G) | max | 782 | 354 | Not Available | Not Available | 2225 | 1009 | 782 | 354 |
| | min | 31.2 | 14.1 | Available | Available | 88.7 | 40.2 | 31.2 | 14.1 |
| 300 psig (20,7 bar G) | max | 1135 | 515 | Not Available | Not Available | 3229 | 1464 | 1135 | 515 |
| | min | 37.6 | 17.0 | Available | Available | 107 | 48.5 | 37.6 | 17.0 |
| 400 psig (27,6 bar G) | max | 1492 | 676 | Not Available | Not Available | 4244 | 1925 | 1492 | 676 |
| | min | 44.1 | 20.0 | Available | Available | 125 | 56.7 | 44.1 | 20.0 |
| 500 psig (34,5 bar G) | max | 1855 | 841 | Not Available | Not Available | 5277 | 2393 | 1855 | 841 |
| | min | 54.8 | 24.9 | Available | Available | 156 | 70.7 | 54.8 | 24.9 |

Note

The Rosemount 8800D measures the volumetric flow under operating conditions (i.e. the actual volume at the operating pressure and temperature—acfm or acmh), as shown above. However, gas volumes are strongly dependent on pressure and temperature. Therefore, gas quantities are typically stated in standard or normal conditions (e.g. SCFM or NCMH). (Standard conditions are typically 59 °F and 14.7 psia. Normal conditions are typically 0 °C and 1.01 bar abs.)

The flow rate limits in standard conditions are found using the equations below:

$$\text{Standard Flow Rate} = \text{Actual Flow Rate} \times \text{Density Ratio}$$

$$\text{Density Ratio} = \text{Density at Actual (Operating) Conditions} / \text{Density at Standard Conditions}$$

Table 38: Saturated steam flow rate limits (assumes steam quality is 100%)

| Process pressure | Flow rate limits | Minimum and maximum saturated steam flow rates for line sizes 1/2-in./DN 25 through 1-in./DN 25 | | | | | | | |
|--------------------------|------------------|---|-------|------------------|-------|-----------------|-------|------------------|-------|
| | | 1 1/2-in./DN 40 | | | | 2-in./DN 50 | | | |
| | | Rosemount 8800D | | Rosemount 8800DR | | Rosemount 8800D | | Rosemount 8800DR | |
| | | lb/hr | kg/hr | lb/hr | kg/hr | lb/hr | kg/hr | lb/hr | kg/hr |
| 15 psig (1,03 bar G) | max | 917 | 416 | 342 | 155 | 1511 | 685 | 917 | 416 |
| | min | 82.0 | 37.2 | 34.8 | 15.8 | 135 | 61.2 | 82.0 | 37.2 |
| 25 psig (1,72 bar G) | max | 1204 | 546 | 449 | 203 | 1983 | 899 | 1204 | 546 |
| | min | 93.9 | 42.6 | 39.9 | 18.1 | 155 | 70.2 | 93.9 | 42.6 |
| 50 psig (3,45 bar G) | max | 1904 | 864 | 711 | 322 | 3138 | 1423 | 1904 | 864 |
| | min | 118 | 53.4 | 50.1 | 22.7 | 195 | 88.3 | 118 | 53.4 |
| 100 psig (6,89 bar G) | max | 3270 | 1483 | 1221 | 554 | 5389 | 2444 | 3270 | 1483 |
| | min | 155 | 70.1 | 65.7 | 29.8 | 255 | 116 | 155 | 70.1 |
| 150 psig (10,3 bar G) | max | 4616 | 2094 | 1724 | 782 | 7609 | 3451 | 4616 | 2094 |
| | min | 184 | 83.2 | 78.1 | 35.4 | 303 | 137 | 184 | 83.2 |
| 200 psig (13,8 bar G) | max | 5956 | 2702 | 2225 | 1009 | 9818 | 4453 | 5956 | 2702 |
| | min | 209 | 94.5 | 88.7 | 40.2 | 344 | 156 | 209 | 94.5 |
| 300 psig (20,7 bar G) | max | 8644 | 3921 | 3229 | 1464 | 14248 | 6463 | 8644 | 3921 |
| | min | 252 | 114 | 107 | 48.5 | 415 | 189 | 252 | 114 |
| 400 psig (27,6 bar G) | max | 11362 | 5154 | 4244 | 1925 | 18727 | 8494 | 11362 | 5154 |
| | min | 295 | 134 | 125 | 56.7 | 487 | 221 | 295 | 134 |
| 500 psig (34,5 bar G) | max | 14126 | 6407 | 5277 | 2393 | 23284 | 10561 | 14126 | 6407 |
| | min | 367 | 167 | 156 | 70.7 | 605 | 274 | 367 | 167 |

Table 39: Saturated steam flow rate limits (assumes steam quality is 100%)

| Process pressure | Flow rate limits | Minimum and maximum saturated steam flow rates for line sizes 3-in./DN 80 through 4-in./DN 100 | | | | | | | |
|-------------------------|------------------|--|-------|------------------|-------|-----------------|-------|------------------|-------|
| | | 3-in./DN 80 | | | | 4-in./DN 100 | | | |
| | | Rosemount 8800D | | Rosemount 8800DR | | Rosemount 8800D | | Rosemount 8800DR | |
| | | lb/hr | kg/hr | lb/hr | kg/hr | lb/hr | kg/hr | lb/hr | kg/hr |
| 15 psig (1,03 bar G) | max | 3330 | 1510 | 1511 | 685 | 5734 | 2601 | 3330 | 1510 |
| | min | 298 | 135 | 135 | 61.2 | 513 | 233 | 298 | 135 |

Table 39: Saturated steam flow rate limits (assumes steam quality is 100%) (continued)

| Process pressure | Flow rate limits | Minimum and maximum saturated steam flow rates for line sizes 3-in./DN 80 through 4-in./DN 100 | | | | | | | |
|--------------------------|------------------|--|-------|------------------|-------|-----------------|-------|------------------|-------|
| | | 3-in./DN 80 | | | | 4-in./DN 100 | | | |
| | | Rosemount 8800D | | Rosemount 8800DR | | Rosemount 8800D | | Rosemount 8800DR | |
| | | lb/hr | kg/hr | lb/hr | kg/hr | lb/hr | kg/hr | lb/hr | kg/hr |
| 25 psig (1,72 bar G) | max | 4370 | 1982 | 1983 | 899 | 7526 | 3414 | 4370 | 1982 |
| | min | 341 | 155 | 155 | 70.2 | 587 | 267 | 341 | 155 |
| 50 psig (3,45 bar G) | max | 6914 | 3136 | 3138 | 1423 | 11905 | 5400 | 6914 | 3136 |
| | min | 429 | 195 | 195 | 88.3 | 739 | 335 | 429 | 195 |
| 100 psig (6,89 bar G) | max | 11874 | 5386 | 5389 | 2444 | 20448 | 9275 | 11874 | 5386 |
| | min | 562 | 255 | 255 | 116 | 968 | 439 | 562 | 255 |
| 150 psig (10,3 bar G) | max | 16763 | 7603 | 7609 | 3451 | 28866 | 13093 | 16763 | 7603 |
| | min | 668 | 303 | 303 | 137 | 1150 | 522 | 668 | 303 |
| 200 psig (13,8 bar G) | max | 21630 | 9811 | 9818 | 4453 | 37247 | 16895 | 21630 | 9811 |
| | min | 759 | 344 | 344 | 156 | 1307 | 593 | 759 | 344 |
| 300 psig (20,7 bar G) | max | 31389 | 14237 | 14248 | 6463 | 54052 | 24517 | 31389 | 14237 |
| | min | 914 | 415 | 415 | 189 | 1574 | 714 | 914 | 415 |
| 400 psig (27,6 bar G) | max | 41258 | 18714 | 18727 | 8494 | 71047 | 32226 | 41258 | 18714 |
| | min | 1073 | 487 | 487 | 221 | 1847 | 838 | 1073 | 487 |
| 500 psig (34,5 bar G) | max | 51297 | 23267 | 23284 | 10561 | 88334 | 40068 | 51297 | 23267 |
| | min | 1334 | 605 | 605 | 274 | 2297 | 1042 | 1334 | 605 |

Table 40: Saturated steam flow rate limits (assumes steam quality is 100%)

| Process pressure | Flow rate limits | Minimum and maximum saturated steam flow rates for line sizes 6-in./DN 150 through 8-in./DN 200 | | | | | | | |
|--------------------------|------------------|---|-------|------------------|-------|-----------------|-------|------------------|-------|
| | | 6-in./DN 150 | | | | 8-in./DN 200 | | | |
| | | Rosemount 8800D | | Rosemount 8800DR | | Rosemount 8800D | | Rosemount 8800DR | |
| | | lb/hr | kg/hr | lb/hr | kg/hr | lb/hr | kg/hr | lb/hr | kg/hr |
| 15 psig (1,03 bar G) | max | 13013 | 5903 | 5734 | 2601 | 22534 | 10221 | 13013 | 5903 |
| | min | 1163 | 528 | 513 | 233 | 2015 | 914 | 1163 | 528 |
| 25 psig (1,72 bar G) | max | 17080 | 7747 | 7526 | 3414 | 29575 | 13415 | 17080 | 7747 |
| | min | 1333 | 605 | 587 | 267 | 2308 | 1047 | 1333 | 605 |
| 50 psig (3,45 bar G) | max | 27019 | 12255 | 11905 | 5400 | 46787 | 21222 | 27019 | 12255 |
| | min | 1676 | 760 | 739 | 335 | 2903 | 1317 | 1676 | 760 |
| 100 psig (6,89 bar G) | max | 46405 | 21049 | 20448 | 9275 | 80356 | 36449 | 46405 | 21049 |
| | min | 2197 | 996 | 968 | 439 | 3804 | 1725 | 2197 | 996 |
| 150 psig (10,3 bar G) | max | 65611 | 29761 | 28866 | 13093 | 113440 | 51455 | 65611 | 29761 |
| | min | 2610 | 1184 | 1150 | 522 | 4520 | 2050 | 2610 | 1184 |
| 200 psig (13,8 bar G) | max | 84530 | 38342 | 37247 | 16895 | 146375 | 66395 | 84530 | 38342 |
| | min | 2965 | 1345 | 1307 | 593 | 5134 | 2329 | 2965 | 1345 |

Table 40: Saturated steam flow rate limits (assumes steam quality is 100%) (continued)

| Process pressure | Flow rate limits | Minimum and maximum saturated steam flow rates for line sizes 6-in./DN 150 through 8-in./DN 200 | | | | | | | |
|--------------------------|------------------|---|-------|------------------|-------|-----------------|--------|------------------|-------|
| | | 6-in./DN 150 | | | | 8-in./DN 200 | | | |
| | | Rosemount 8800D | | Rosemount 8800DR | | Rosemount 8800D | | Rosemount 8800DR | |
| | | lb/hr | kg/hr | lb/hr | kg/hr | lb/hr | kg/hr | lb/hr | kg/hr |
| 300 psig (20,7 bar G) | max | 122666 | 55640 | 54052 | 24517 | 212411 | 96348 | 122666 | 55640 |
| | min | 3572 | 1620 | 1574 | 714 | 6185 | 2805 | 3572 | 1620 |
| 400 psig (27,6 bar G) | max | 161236 | 73135 | 71047 | 32226 | 279200 | 126643 | 161236 | 73135 |
| | min | 4192 | 1901 | 1847 | 838 | 7259 | 3293 | 4192 | 1901 |
| 500 psig (34,5 bar G) | max | 200468 | 90931 | 88334 | 40068 | 347134 | 157457 | 200468 | 90931 |
| | min | 5212 | 2364 | 2297 | 1042 | 9025 | 4094 | 5212 | 2364 |

Table 41: Saturated steam flow rate limits (assumes steam quality is 100%)

| Process pressure | Flow rate limits | Minimum and maximum saturated steam flow rates for line sizes 10-in./DN 250 through 12-in./DN 300 | | | | | | | |
|--------------------------|------------------|---|--------|------------------|--------|-----------------|--------|------------------|--------|
| | | 10-in./DN 250 | | | | 12-in./DN 300 | | | |
| | | Rosemount 8800D | | Rosemount 8800DR | | Rosemount 8800D | | Rosemount 8800DR | |
| | | lb/hr | kg/hr | lb/hr | kg/hr | lb/hr | kg/hr | lb/hr | kg/hr |
| 15 psig (1,03 bar G) | max | 35519 | 16111 | 22534 | 10221 | 50994 | 23130 | 35519 | 16111 |
| | min | 3175 | 1440 | 2015 | 914 | 4554 | 2066 | 3175 | 1440 |
| 25 psig (1,72 bar G) | max | 46618 | 21146 | 29575 | 13415 | 66862 | 30328 | 46618 | 21146 |
| | min | 4570 | 2073 | 2308 | 1047 | 5218 | 2367 | 4570 | 2073 |
| 50 psig (3,45 bar G) | max | 73748 | 33452 | 46787 | 21222 | 105774 | 47978 | 73748 | 33452 |
| | min | 4575 | 2075 | 2903 | 1317 | 6562 | 2976 | 4575 | 2075 |
| 100 psig (6,89 bar G) | max | 126660 | 57452 | 80356 | 36449 | 181663 | 82401 | 126660 | 57452 |
| | min | 5996 | 2720 | 3804 | 1725 | 8600 | 3901 | 5996 | 2720 |
| 150 psig (10,3 bar G) | max | 178808 | 81106 | 113440 | 51455 | 256457 | 116327 | 178808 | 81106 |
| | min | 7125 | 3232 | 4520 | 2050 | 10218 | 4635 | 7125 | 3232 |
| 200 psig (13,8 bar G) | max | 230722 | 104654 | 146375 | 66395 | 330915 | 150101 | 230722 | 104654 |
| | min | 8092 | 3670 | 5134 | 2329 | 11607 | 5265 | 8092 | 3670 |
| 300 psig (20,7 bar G) | max | 334810 | 151867 | 212411 | 96348 | 480203 | 217816 | 334810 | 151867 |
| | min | 9749 | 4422 | 6185 | 2805 | 13983 | 6343 | 9749 | 4422 |
| 400 psig (27,6 bar G) | max | 440085 | 199619 | 279200 | 126643 | 631195 | 286305 | 440085 | 199619 |
| | min | 11442 | 5190 | 7259 | 3293 | 16411 | 7444 | 11442 | 5190 |
| 500 psig (34,5 bar G) | max | 547165 | 248190 | 347134 | 157457 | 784775 | 355968 | 547165 | 248190 |
| | min | 14226 | 6453 | 9025 | 4094 | 20404 | 9255 | 14226 | 6453 |

Product certifications

For information about product certifications, refer to *Rosemount™ 8800D Series Vortex Flowmeter Approval Document* (00825-VA00-0001). You can find it at [Emerson.com](https://www.emerson.com) or contact an Emerson Flow representative.

Dimensional drawings

Single transmitter dimensions and weights

Flanged style flow meter (½-inch through 12-inch/15 mm through 300 mm line sizes)

Dimensions are in inches (millimeters).

Figure 6: Dimensional drawing for ½ inch through 1½ inch (15 mm through 40 mm) flanged style flow meter

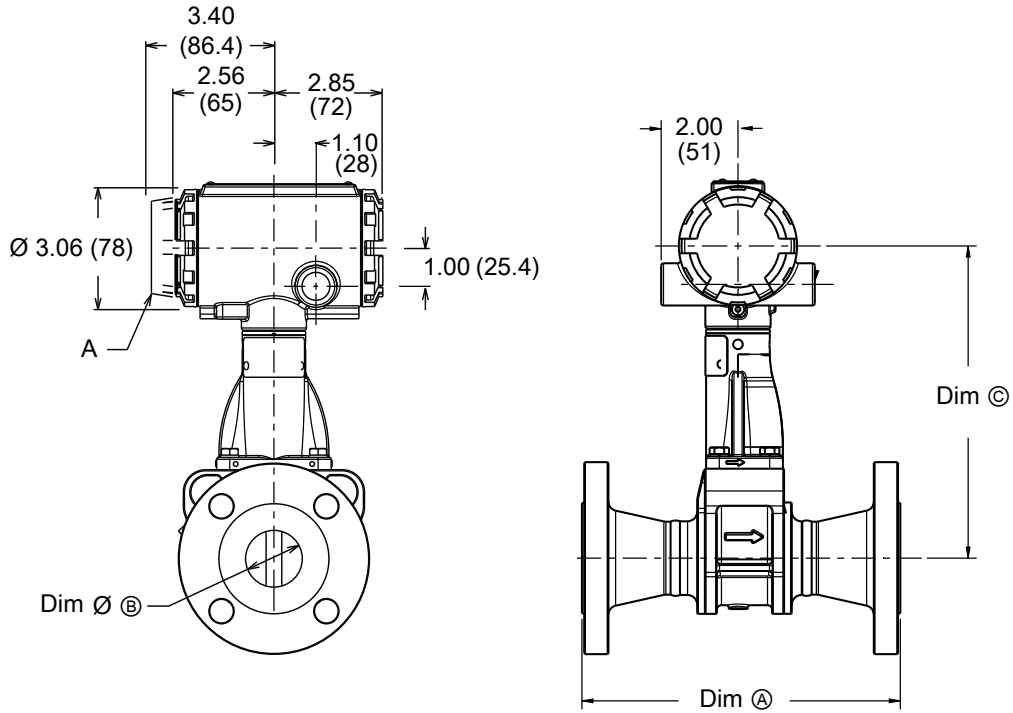

A Display option

Note
See Table 42 for Dim A, ØB, and Dim C values.

Figure 7: Dimensional drawing for 2 inch through 12 inch (50 mm through 300 mm) flanged style flow meter

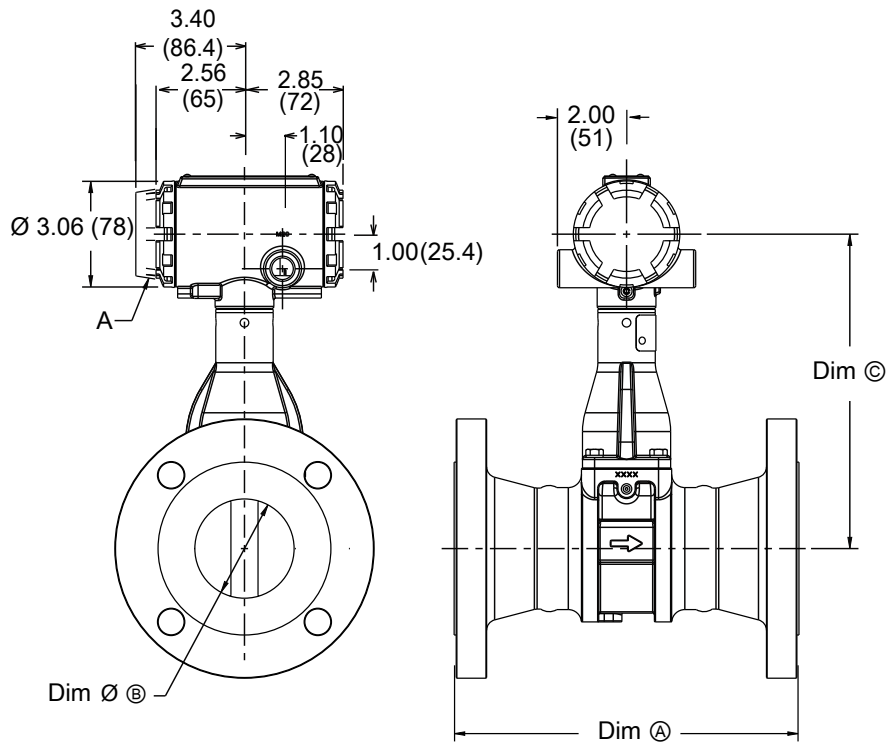

A Display option

Note
See [Table 42](#) for Dim A, Dim ØB, and Dim C values.

Table 42: Dimensions and weights for flanged style flow meter

| Nominal size inch (mm) | Flange rating | Dim A inch (mm) | Dim A (RTJ) inch (mm) | Dim ØB inch (mm) | Dim C inch (mm) | Weight lb (kg) ⁽¹⁾ |
|---------------------------|---------------|--------------------|--------------------------|---------------------|--------------------|----------------------------------|
| ½ (15) | Class 150 | 6.8 (173) | N/A | 0.54 (13,7) | 7.6 (193) | 9 (4) |
| | Class 300 | 7.2 (183) | 7.6 (193) | 0.54 (13,7) | 7.6 (193) | 10 (5) |
| | Class 600 | 7.7 (196) | 7.6 (193) | 0.54 (13,7) | 7.6 (193) | 11 (5) |
| | Class 900 | 8.3 (211) | 8.3 (211) | 0.54 (13,7) | 7.6 (193) | 15 (7) |
| | PN 16/40 | 6.1 (155) | N/A | 0.54 (13,7) | 7.6 (193) | 10 (5) |
| | PN 100 | 6.6 (168) | N/A | 0.54 (13,7) | 7.6 (193) | 12 (6) |
| | JIS 10K/20K | 6.3 (160) | N/A | 0.54 (13,7) | 7.6 (193) | 10 (5) |
| | JIS 40K | 7.3 (185) | N/A | 0.54 (13,7) | 7.6 (193) | 14 (6) |

Table 42: Dimensions and weights for flanged style flow meter (continued)

| Nominal size inch (mm) | Flange rating | Dim Ⓐ inch (mm) | Dim Ⓐ (RTJ) inch (mm) | Dim ØⒷ inch (mm) | Dim © inch (mm) | Weight lb (kg) ⁽¹⁾ |
|---------------------------|---------------|--------------------|--------------------------|---------------------|--------------------|----------------------------------|
| 1 (25) | Class 150 | 7.5 (191) | 7.8 (198) | 0.95 (24,1) | 7.7 (196) | 12 (6) |
| | Class 300 | 8.0 (203) | 8.4 (213) | 0.95 (24,1) | 7.7 (196) | 15 (7) |
| | Class 600 | 8.5 (216) | 8.5 (216) | 0.95 (24,1) | 7.7 (196) | 16 (7) |
| | Class 900 | 9.4 (239) | 9.4 (239) | 0.95 (24,1) | 7.7 (196) | 24 (11) |
| | Class 1500 | 9.4 (239) | 9.4 (239) | 0.95 (24,1) | 7.7 (196) | 24 (11) |
| | PN 16/40 | 6.2 (157) | N/A | 0.95 (24,1) | 7.7 (196) | 14 (6) |
| | PN 100 | 7.7 (196) | N/A | 0.95 (24,1) | 7.7 (196) | 20 (9) |
| | PN 160 | 7.7 (196) | N/A | 0.95 (24,1) | 7.7 (196) | 20 (9) |
| | JIS 10K/20K | 6.5 (165) | N/A | 0.95 (24,1) | 7.7 (196) | 14 (6) |
| | JIS 40K | 7.8 (198) | N/A | 0.95 (24,1) | 7.7 (196) | 18 (8) |
| 1½ (40) | Class 150 | 8.2 (208) | 8.6 (218) | 1.49 (37,8) | 8.1 (206) | 18 (8) |
| | Class 300 | 8.7 (221) | 9.1 (231) | 1.49 (37,8) | 8.1 (206) | 23 (10) |
| | Class 600 | 9.3 (236) | 9.3 (236) | 1.49 (37,8) | 8.1 (206) | 26 (12) |
| | Class 900 | 10.3 (262) | 10.3 (262) | 1.49 (37,8) | 8.1 (206) | 37 (17) |
| | Class 1500 | 10.3 (262) | 10.3 (262) | 1.49 (37,8) | 8.1 (206) | 37 (17) |
| | PN 16/40 | 6.9 (175) | N/A | 1.49 (37,8) | 8.1 (206) | 19 (9) |
| | PN 100 | 8.2 (208) | N/A | 1.49 (37,8) | 8.1 (206) | 28 (13) |
| | PN 160 | 8.4 (213) | N/A | 1.49 (37,8) | 8.1 (206) | 30 (13) |
| | JIS 10K/20K | 7.3 (185) | N/A | 1.49 (37,8) | 8.1 (206) | 19 (8) |
| | JIS 40K | 8.4 (213) | N/A | 1.49 (37,8) | 8.1 (206) | 26 (12) |
| 2 (50) | Class 150 | 9.2 (234) | 9.6 (243) | 1.92 (48,8) | 8.5 (216) | 22 (10) |
| | Class 300 | 9.7 (246) | 10.2 (259) | 1.92 (48,8) | 8.5 (216) | 26 (12) |
| | Class 600 | 10.5 (267) | 10.6 (269) | 1.92 (48,8) | 8.5 (216) | 30 (14) |
| | Class 900 | 12.7 (323) | 12.9 (328) | 1.92 (48,8) | 8.5 (216) | 60 (27) |
| | Class 1500 | 12.7 (323) | 12.9 (328) | 1.67 (42,4) | 8.5 (216) | 62 (28) |
| | PN 16/40 | 8.0 (203) | N/A | 1.92 (48,8) | 8.5 (216) | 23 (11) |
| | PN 63/64 | 9.1 (231) | N/A | 1.92 (48,8) | 8.5 (216) | 31 (14) |
| | PN 100 | 9.6 (244) | N/A | 1.92 (48,8) | 8.5 (216) | 37 (17) |
| | PN 160 | 10.2 (259) | N/A | 1.92 (48,8) | 8.5 (216) | 39 (18) |
| | PN 250 | 10.9 (277) | N/A | 1.67 (42,4) | 8.5 (216) | 47 (22) |
| | JIS 10K | 7.7 (195) | N/A | 1.92 (48,8) | 8.5 (216) | 20 (9) |
| | JIS 20K | 8.3 (210) | N/A | 1.92 (48,8) | 8.5 (216) | 20 (9) |
| | JIS 40K | 9.8 (249) | N/A | 1.92 (48,8) | 8.5 (216) | 29 (13) |

Table 42: Dimensions and weights for flanged style flow meter (continued)

| Nominal size inch (mm) | Flange rating | Dim Ⓐ inch (mm) | Dim Ⓐ (RTJ) inch (mm) | Dim ØⒷ inch (mm) | Dim © inch (mm) | Weight lb (kg) ⁽¹⁾ |
|---------------------------|---------------|--------------------|--------------------------|---------------------|--------------------|----------------------------------|
| 3 (80) | Class 150 | 9.9 (251) | 10.3 (262) | 2.87 (72,9) | 9.1 (231) | 37 (17) |
| | Class 300 | 10.6 (269) | 11.1 (282) | 2.87 (72,9) | 9.1 (231) | 47 (21) |
| | Class 600 | 11.4 (290) | 11.5 (292) | 2.87 (72,9) | 9.1 (231) | 53 (24) |
| | Class 900 | 12.9 (328) | 13.0 (330) | 2.87 (72,9) | 9.1 (231) | 76 (35) |
| | Class 1500 | 14.1 (358) | 14.2 (361) | 2.60 (66) | 9.1 (231) | 109 (49) |
| | PN 16/40 | 8.9 (226) | N/A | 2.87 (72,9) | 9.1 (231) | 37 (17) |
| | PN 63/64 | 10.0 (254) | N/A | 2.87 (72,9) | 9.1 (231) | 45 (21) |
| | PN 100 | 10.5 (267) | N/A | 2.87 (72,9) | 9.1 (231) | 55 (25) |
| | PN 160 | 11.1 (282) | N/A | 2.87 (72,9) | 9.1 (231) | 60 (27) |
| | JIS 10K | 7.9 (201) | N/A | 2.87 (72,9) | 9.1 (231) | 28 (13) |
| | JIS 20K | 9.3 (236) | N/A | 2.87 (72,9) | 9.1 (231) | 35 (16) |
| | JIS 40K | 11.0 (279) | N/A | 2.87 (72,9) | 9.1 (231) | 50 (29) |
| 4 (100) | Class 150 | 10.3 (262) | 10.6 (269) | 3.79 (96,3) | 9.6 (244) | 51 (23) |
| | Class 300 | 11.0 (279) | 11.5 (292) | 3.79 (96,3) | 9.6 (244) | 72 (32) |
| | Class 600 | 12.8 (325) | 12.9 (328) | 3.79 (96,3) | 9.6 (244) | 98 (44) |
| | Class 900 | 13.8 (351) | 13.9 (353) | 3.79 (96,3) | 9.6 (244) | 121 (55) |
| | Class 1500 | 14.5 (368) | 14.6 (371) | 3.40 (86,4) | 9.6 (244) | 163 (74) |
| | PN 16 | 8.4 (213) | N/A | 3.79 (96,3) | 9.6 (244) | 40 (18) |
| | PN 40 | 9.4 (239) | N/A | 3.79 (96,3) | 9.6 (244) | 50 (22) |
| | PN 63/64 | 10.4 (264) | N/A | 3.79 (96,3) | 9.6 (244) | 63 (28) |
| | PN 100 | 11.3 (287) | N/A | 3.79 (96,3) | 9.6 (244) | 79 (36) |
| | PN 160 | 12.1 (307) | N/A | 3.79 (96,3) | 9.6 (244) | 86 (39) |
| | JIS 10K | 8.7 (220) | N/A | 3.79 (96,3) | 9.6 (244) | 38 (17) |
| | JIS 20K | 8.7 (220) | N/A | 3.79 (96,3) | 9.6 (244) | 45 (21) |
| | JIS 40K | 11.8 (300) | N/A | 3.79 (96,3) | 9.6 (244) | 76 (34) |

Table 42: Dimensions and weights for flanged style flow meter (continued)

| Nominal size inch (mm) | Flange rating | Dim Ⓐ inch (mm) | Dim Ⓐ (RTJ) inch (mm) | Dim ØⒷ inch (mm) | Dim © inch (mm) | Weight lb (kg) ⁽¹⁾ |
|---------------------------|---------------|--------------------|--------------------------|---------------------|--------------------|----------------------------------|
| 6 (150) | Class 150 | 11.6 (295) | 12.0 (305) | 5.7 (144,8) | 10.8 (274) | 81 (37) |
| | Class 300 | 12.3 (312) | 12.8 (325) | 5.7 (144,8) | 10.8 (274) | 120 (55) |
| | Class 600 | 14.3 (363) | 14.4 (366) | 5.7 (144,8) | 10.8 (274) | 187 (55) |
| | Class 900 | 16.1 (409) | 16.2 (411) | 5.14 (130,6) | 10.8 (274) | 278 (126) |
| | Class 1500 | 18.6 (472) | 18.8 (478) | 5.14 (130,6) | 10.8 (274) | 376 (170) |
| | PN 16 | 8.9 (226) | N/A | 5.7 (144,8) | 10.8 (274) | 66 (30) |
| | PN 40 | 10.5 (267) | N/A | 5.7 (144,8) | 10.8 (274) | 86 (39) |
| | PN 63/64 | 12.1 (307) | N/A | 5.7 (144,8) | 10.8 (274) | 130 (59) |
| | PN 100 | 13.6 (345) | N/A | 5.7 (144,8) | 10.8 (274) | 160 (73) |
| | JIS 10K | 10.6 (270) | N/A | 5.7 (144,8) | 10.8 (274) | 70 (32) |
| | JIS 20K | 10.6 (270) | N/A | 5.7 (144,8) | 10.8 (274) | 88 (40) |
| | JIS 40K | 14.2 (361) | N/A | 5.7 (144,8) | 10.8 (274) | 166 (75) |
| 8 (200) | Class 150 | 13.5 (343) | 13.9 (353) | 7.55 (191,8) | 11.7 (297) | 142 (64) |
| | Class 300 | 14.3 (363) | 14.8 (376) | 7.55 (191,8) | 11.7 (297) | 199 (90) |
| | Class 600 | 16.5 (419) | 16.7 (424) | 7.55 (191,8) | 11.7 (297) | 299 (135) |
| | Class 900 | 18.8 (478) | 18.9 (480) | 6.62 (168,1) | 11.7 (297) | 479 (217) |
| | Class 1500 | 22.8 (579) | 23.2 (589) | 6.62 (168,1) | 11.7 (297) | 652 (296) |
| | PN 10 | 10.4 (264) | N/A | 7.55 (191,8) | 11.7 (297) | 111 (50) |
| | PN 16 | 10.4 (264) | N/A | 7.55 (191,8) | 11.7 (297) | 109 (50) |
| | PN 25 | 11.8 (300) | N/A | 7.55 (191,8) | 11.7 (297) | 138 (63) |
| | PN 40 | 12.5 (318) | N/A | 7.55 (191,8) | 11.7 (297) | 157 (71) |
| | PN 63/64 | 14.2 (361) | N/A | 7.55 (191,8) | 11.7 (297) | 217 (99) |
| | PN 100 | 15.8 (401) | N/A | 7.55 (191,8) | 11.7 (297) | 283 (128) |
| | JIS 10K | 12.2 (310) | N/A | 7.55 (191,8) | 11.7 (297) | 110 (50) |
| | JIS 20K | 12.2 (310) | N/A | 7.55 (191,8) | 11.7 (297) | 135 (61) |
| | JIS 40K | 16.5 (419) | N/A | 7.55 (191,8) | 11.7 (297) | 256 (116) |

Table 42: Dimensions and weights for flanged style flow meter (continued)

| Nominal size inch (mm) | Flange rating | Dim Ⓐ inch (mm) | Dim Ⓐ (RTJ) inch (mm) | Dim ØⒷ inch (mm) | Dim © inch (mm) | Weight lb (kg) ⁽¹⁾ |
|---------------------------|---------------|--------------------|--------------------------|---------------------|--------------------|----------------------------------|
| 10 (250) | Class 150 | 14.5 (368) | 14.9 (378) | 9.56 (243) | 12.8 (325) | 198 (90) |
| | Class 300 | 15.8 (401) | 16.3 (414) | 9.56 (243) | 12.8 (325) | 286 (130) |
| | Class 600 | 19.0 (483) | 19.2 (488) | 9.56 (243) | 12.8 (325) | 478 (220) |
| | PN 10 | 11.9 (302) | N/A | 9.56 (243) | 12.8 (325) | 157 (71) |
| | PN 16 | 12.0 (305) | N/A | 9.56 (243) | 12.8 (325) | 162 (74) |
| | PN 25 | 13.5 (343) | N/A | 9.56 (243) | 12.8 (325) | 199 (90) |
| | PN 40 | 14.8 (376) | N/A | 9.56 (243) | 12.8 (325) | 247 (112) |
| | PN 63/64 | 16.4 (417) | N/A | 9.56 (243) | 12.8 (325) | 308 (140) |
| | PN 100 | 18.9 (480) | N/A | 9.56 (243) | 12.8 (325) | 445 (202) |
| | JIS 10K | 14.5 (368) | N/A | 9.56 (243) | 12.8 (325) | 175 (79) |
| | JIS 20K | 14.5 (368) | N/A | 9.56 (243) | 12.8 (325) | 222 (101) |
| | JIS 40K | 18.1 (460) | N/A | 9.56 (243) | 12.8 (325) | 379 (172) |
| 12 (300) | Class 150 | 16.8 (427) | 17.1 (434) | 11.38 (289) | 13.7 (348) | 298 (135) |
| | Class 300 | 18.0 (457) | 18.5 (470) | 11.38 (289) | 13.7 (348) | 416 (189) |
| | Class 600 | 20.5 (521) | 20.6 (523) | 11.38 (289) | 13.7 (348) | 595 (270) |
| | PN 10 | 13.1 (333) | N/A | 11.38 (289) | 13.7 (348) | 204 (93) |
| | PN 16 | 13.9 (353) | N/A | 11.38 (289) | 13.7 (348) | 225 (102) |
| | PN 25 | 15.0 (381) | N/A | 11.38 (289) | 13.7 (348) | 269 (122) |
| | PN 40 | 16.8 (427) | N/A | 11.38 (289) | 13.7 (348) | 348 (158) |
| | PN 63/64 | 18.8 (478) | N/A | 11.38 (289) | 13.7 (348) | 431 (196) |
| | PN 100 | 21.2 (538) | N/A | 11.38 (289) | 13.7 (348) | 644 (292) |
| | JIS 10K | 15.7 (399) | N/A | 11.38 (289) | 13.7 (348) | 223 (101) |
| | JIS 20K | 15.7 (399) | N/A | 11.38 (289) | 13.7 (348) | 284 (129) |
| | JIS 40K | 19.6 (498) | N/A | 11.38 (289) | 13.7 (348) | 494 (224) |

(1) With integral transmitter, and without MTA or CPA options.

Reducer style flow meter

Figure 8: Dimensional drawing for reducer style flow meters

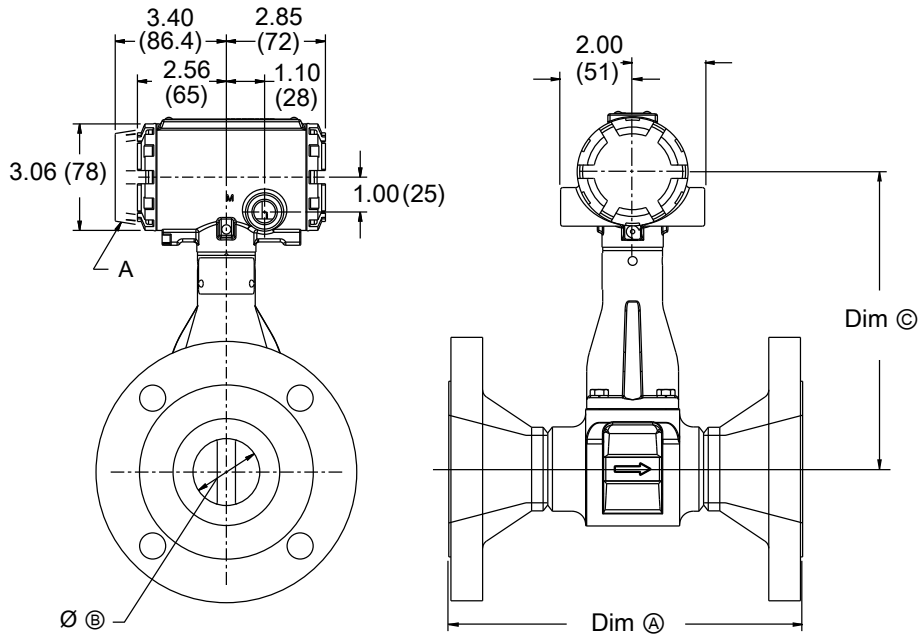

A Display option

Note

See [Table 43](#) for Dim A, ØB, and Dim C values.

Table 43: Dimensions and weights for reducer style flow meter

| Nominal size inch (mm) | Flange rating | Face-to-face Dim A inch (mm) | Dim A RTJ inch (mm) | Dim ØB inch (mm) | Dim C inch (mm) | Weight lb (kg) |
|---------------------------|---------------|------------------------------------|------------------------|---------------------|--------------------|----------------|
| 1 (25) | Class 150 | 7.5 (191) | 7.9 (201) | 0.54 (13,7) | 7.6 (193) | 12 (5) |
| | Class 300 | 8.0 (203) | 8.4 (213) | 0.54 (13,7) | 7.6 (193) | 14 (6) |
| | Class 600 | 8.5 (216) | 8.5 (216) | 0.54 (13,7) | 7.6 (193) | 15 (7) |
| | Class 900 | 9.4 (239) | 9.4 (239) | 0.54 (13,7) | 7.6 (193) | 21 (9) |
| | PN 16/40 | 6.2 (157) | N/A | 0.54 (13,7) | 7.6 (193) | 13 (6) |
| | PN 100 | 7.7 (196) | N/A | 0.54 (13,7) | 7.6 (193) | 18 (8) |

Table 43: Dimensions and weights for reducer style flow meter (continued)

| Nominal size inch (mm) | Flange rating | Face-to-face Dim [Ⓐ] inch (mm) | Dim [Ⓐ] RTJ inch (mm) | Dim [Ⓑ] inch (mm) | Dim [Ⓒ] inch (mm) | Weight lb (kg) |
|---------------------------|---------------|---|-----------------------------------|-------------------------------|-------------------------------|----------------|
| 1 ½ (40) | Class 150 | 8.2 (208) | 8.6 (218) | 0.95 (24,1) | 7.7 (196) | 16 (7) |
| | Class 300 | 8.7 (221) | 9.1 (231) | 0.95 (24,1) | 7.7 (196) | 21 (10) |
| | Class 600 | 9.3 (236) | 9.3 (236) | 0.95 (24,1) | 7.7 (196) | 24 (11) |
| | Class 900 | 10.3 (262) | 10.3 (262) | 0.95 (24,1) | 7.7 (196) | 35 (16) |
| | PN 16/40 | 6.9 (175) | N/A | 0.95 (24,1) | 7.7 (196) | 18 (8) |
| | PN 100 | 8.2 (208) | N/A | 0.95 (24,1) | 7.7 (196) | 26 (12) |
| | PN 160 | 8.4 (213) | N/A | 0.95 (24,1) | 7.7 (196) | 28 (13) |
| 2 (50) | Class 150 | 9.2 (234) | 9.6 (244) | 1.49 (37,8) | 8.1 (206) | 23 (10) |
| | Class 300 | 9.7 (246) | 10.3 (262) | 1.49 (37,8) | 8.1 (206) | 27 (12) |
| | Class 600 | 10.5 (267) | 10.6 (269) | 1.49 (37,8) | 8.1 (206) | 31 (14) |
| | Class 900 | 12.7 (323) | 12.9 (328) | 1.49 (37,8) | 8.1 (206) | 61 (28) |
| | PN 16/40 | 8.0 (203) | N/A | 1.49 (37,8) | 8.1 (206) | 24 (11) |
| | PN 63/64 | 9.1 (231) | N/A | 1.49 (37,8) | 8.1 (206) | 31 (14) |
| | PN 100 | 9.6 (244) | N/A | 1.49 (37,8) | 8.1 (206) | 37 (17) |
| | PN 160 | 10.2 (259) | N/A | 1.49 (37,8) | 8.1 (206) | 40 (18) |
| 3 (80) | Class 150 | 9.9 (251) | 10.3 (262) | 1.92 (48,8) | 8.5 (216) | 33 (15) |
| | Class 300 | 10.6 (269) | 11.1 (282) | 1.92 (48,8) | 8.5 (216) | 43 (19) |
| | Class 600 | 11.4 (290) | 11.5 (292) | 1.92 (48,8) | 8.5 (216) | 49 (22) |
| | Class 900 | 12.9 (328) | 13.0 (330) | 1.92 (48,8) | 8.5 (216) | 73 (33) |
| | PN 16/40 | 8.9 (226) | N/A | 1.92 (48,8) | 8.5 (216) | 33 (15) |
| | PN 63/64 | 10.0 (254) | N/A | 1.92 (48,8) | 8.5 (216) | 42 (19) |
| | PN 100 | 10.5 (267) | N/A | 1.92 (48,8) | 8.5 (216) | 52 (24) |
| | PN 160 | 11.1 (282) | N/A | 1.92 (48,8) | 8.5 (216) | 58 (26) |
| 4 (100) | Class 150 | 10.3 (262) | 10.7 (272) | 2.87 (72,9) | 9.1 (231) | 46 (21) |
| | Class 300 | 11.0 (279) | 11.5 (282) | 2.87 (72,9) | 9.1 (231) | 67 (30) |
| | Class 600 | 12.8 (325) | 12.9 (328) | 2.87 (72,9) | 9.1 (231) | 94 (43) |
| | Class 900 | 13.8 (351) | 13.9 (353) | 2.87 (72,9) | 9.1 (231) | 118 (54) |
| | PN 16 | 8.4 (213) | N/A | 2.87 (72,9) | 9.1 (231) | 36 (16) |
| | PN 40 | 9.4 (239) | N/A | 2.87 (72,9) | 9.1 (231) | 46 (21) |
| | PN 63/64 | 10.4 (264) | N/A | 2.87 (72,9) | 9.1 (231) | 60 (27) |
| | PN 100 | 11.3 (287) | N/A | 2.87 (72,9) | 9.1 (231) | 77 (35) |
| | PN 160 | 12.1 (307) | N/A | 2.87 (72,9) | 9.1 (231) | 85 (38) |

Table 43: Dimensions and weights for reducer style flow meter (continued)

| Nominal size inch (mm) | Flange rating | Face-to-face Dim [Ⓐ] inch (mm) | Dim [Ⓐ] RTJ inch (mm) | Dim [Ⓞ] inch (mm) | Dim [Ⓒ] inch (mm) | Weight lb (kg) |
|---------------------------|---------------|---|-----------------------------------|-------------------------------|-------------------------------|----------------|
| 6 (150) | Class 150 | 11.6 (295) | 12.0 (305) | 3.79 (96,3) | 9.6 (244) | 70 (32) |
| | Class 300 | 12.3 (312) | 12.9 (328) | 3.79 (96,3) | 9.6 (244) | 113 (51) |
| | Class 600 | 14.3 (363) | 14.4 (366) | 3.79 (96,3) | 9.6 (244) | 185 (84) |
| | Class 900 | 16.1 (409) | 16.2 (411) | 3.79 (96,3) | 9.6 (244) | 246 (112) |
| | PN 16 | 8.9 (226) | N/A | 3.79 (96,3) | 9.6 (244) | 59 (27) |
| | PN 40 | 10.5 (267) | N/A | 3.79 (96,3) | 9.6 (244) | 82 (37) |
| | PN 63/64 | 12.1 (307) | N/A | 3.79 (96,3) | 9.6 (244) | 125 (57) |
| | PN 100 | 13.6 (345) | N/A | 3.79 (96,3) | 9.6 (244) | 162 (73) |
| | PN 160 | 14.7 (373) | N/A | 3.79 (96,3) | 9.6 (244) | 188 (85) |
| 8 (200) | Class 150 | 13.5 (343) | 14.0 (356) | 5.70 (144,8) | 10.8 (274) | 124 (56) |
| | Class 300 | 14.3 (363) | 14.8 (376) | 5.70 (144,8) | 10.8 (274) | 186 (84) |
| | Class 600 | 16.5 (419) | 16.7 (424) | 5.70 (144,8) | 10.8 (274) | 295 (134) |
| | PN 10 | 10.4 (264) | N/A | 5.70 (144,8) | 10.8 (274) | 91 (41) |
| | PN 16 | 10.4 (264) | N/A | 5.70 (144,8) | 10.8 (274) | 91 (41) |
| | PN 25 | 11.8 (300) | N/A | 5.70 (144,8) | 10.8 (274) | 124 (56) |
| | PN 40 | 12.5 (318) | N/A | 5.70 (144,8) | 10.8 (274) | 145 (66) |
| | PN 63/64 | 14.2 (361) | N/A | 5.70 (144,8) | 10.8 (274) | 211 (96) |
| | PN 100 | 15.8 (401) | N/A | 5.70 (144,8) | 10.8 (274) | 283 (128) |
| 10 (250) | Class 150 | 14.5 (368) | 14.9 (378) | 7.55 (191,8) | 11.7 (297) | 182 (83) |
| | Class 300 | 15.8 (401) | 16.3 (414) | 7.55 (191,8) | 11.7 (297) | 282 (128) |
| | Class 600 | 19.0 (483) | 19.2 (488) | 7.55 (191,8) | 11.7 (297) | 490 (222) |
| | PN 10 | 11.9 (302) | N/A | 7.55 (191,8) | 11.7 (297) | 139 (63) |
| | PN 16 | 12.0 (305) | N/A | 7.55 (191,8) | 11.7 (297) | 149 (67) |
| | PN 25 | 13.5 (343) | N/A | 7.55 (191,8) | 11.7 (297) | 191 (87) |
| | PN 40 | 14.8 (376) | N/A | 7.55 (191,8) | 11.7 (297) | 246 (112) |
| | PN 63/64 | 16.4 (417) | N/A | 7.55 (191,8) | 11.7 (297) | 314 (143) |
| | PN 100 | 18.9 (480) | N/A | 7.55 (191,8) | 11.7 (297) | 463 (210) |

Table 43: Dimensions and weights for reducer style flow meter (continued)

| Nominal size inch (mm) | Flange rating | Face-to-face Dim Ⓐ inch (mm) | Dim Ⓐ RTJ inch (mm) | Dim ØⒷ inch (mm) | Dim Ⓒ inch (mm) | Weight lb (kg) |
|------------------------|---------------|------------------------------|---------------------|------------------|-----------------|----------------|
| 12 (300) | Class 150 | 16.8 (427) | 17.1 (434) | 9.56 (242,8) | 12.8 (325) | 282 (128) |
| | Class 300 | 18.0 (457) | 18.5 (470) | 9.56 (242,8) | 12.8 (325) | 412 (187) |
| | Class 600 | 20.5 (521) | 20.6 (523) | 9.56 (242,8) | 12.8 (325) | 610 (297) |
| | PN 10 | 13.1 (333) | N/A | 9.56 (242,8) | 12.8 (325) | 188 (85) |
| | PN 16 | 13.9 (353) | N/A | 9.56 (242,8) | 12.8 (325) | 212 (96) |
| | PN 25 | 15.0 (381) | N/A | 9.56 (242,8) | 12.8 (325) | 262 (119) |
| | PN 40 | 16.8 (427) | N/A | 9.56 (242,8) | 12.8 (325) | 350 (159) |
| | PN 63/64 | 18.8 (478) | N/A | 9.56 (242,8) | 12.8 (325) | 444 (201) |
| | PN 100 | 21.2 (538) | N/A | 9.56 (242,8) | 12.8 (325) | 672 (305) |
| 14 (350) | Class 150 | 19.8 (502) | - | 11.38 (289.0) | 13.7 (348) | 410 (186) |
| | Class 300 | 19.8 (502) | - | 11.38 (289) | 13.7 (348) | 508 (230) |

Wafer style flow meters

Figure 9: Dimensional drawing for wafer style flow meters

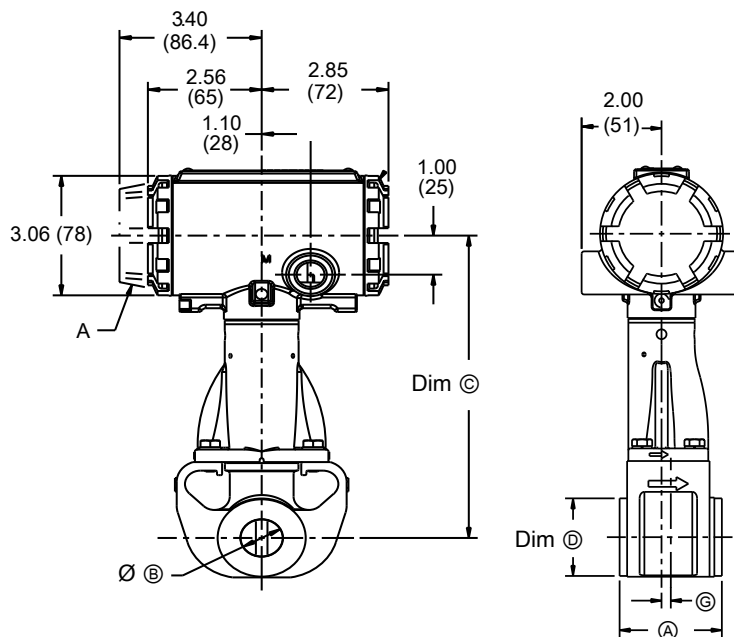

A Display option

Note

See Table 44 for Dim Ⓐ, ØⒷ, Dim Ⓒ, Dim Ⓓ, and Dim Ⓔ.

Table 44: Dimensions and weights for wafer-style flow meter

| Nominal size inch (mm) | Face-to-face Dim Ⓐ Inch (mm) | Ø Ⓑ Inch (mm) | Dim Ⓒ Inch (mm) | Dim Ⓓ Inch (mm) | Dim Ⓔ Inch (mm) | Weight lb (kg) ⁽¹⁾ |
|---------------------------|------------------------------------|---------------|--------------------|--------------------|--------------------|----------------------------------|
| ½ (15) | 2.56 (65) | 0.54 (13,2) | 7.63 (194) | 1.38 (35,1) | 0.17 (4,3) | 6.8 (3,1) |
| 1 (25) | 2.56 (65) | 0.95 (24,1) | 7.74 (197) | 1.98 (50,3) | 0.23 (5,9) | 7.4 (3,4) |
| 1½ (40) | 2.56 (65) | 1.49 (37,8) | 8.14 (207) | 2.87 (72,9) | 0.18 (4,6) | 10.0 (4,5) |
| 2 (50) | 2.56 (65) | 1.92 (49) | 8.85 (225) | 3.86 (98) | 0.12 (3) | 10.6 (4,8) |
| 3 (80) | 2.56 (65) | 2.87 (73) | 9.62 (244) | 5.00 (127) | 0.25 (6) | 13.6 (6,2) |
| 4 (100) | 3.42 (87) | 3.79 (96) | 10.48 (266) | 6.20 (157,5) | 0.44 (11) | 21.4 (9,7) |
| 6 (150) | 5.00 (127) | 5.70 (145) | 10.29 (261) | 8.50 (216) | 0.30 (7,6) | 36 (16) |
| 8 (200) | 6.60 (168) | 7.55 (192) | 11.22 (285) | 10.62 (270) | 0.70 (17,8) | 62 (28) |

(1) With integral transmitter, and without CPA option.

Weld end style flow meters

Figure 10: Dimensional drawing for weld end style flow meters

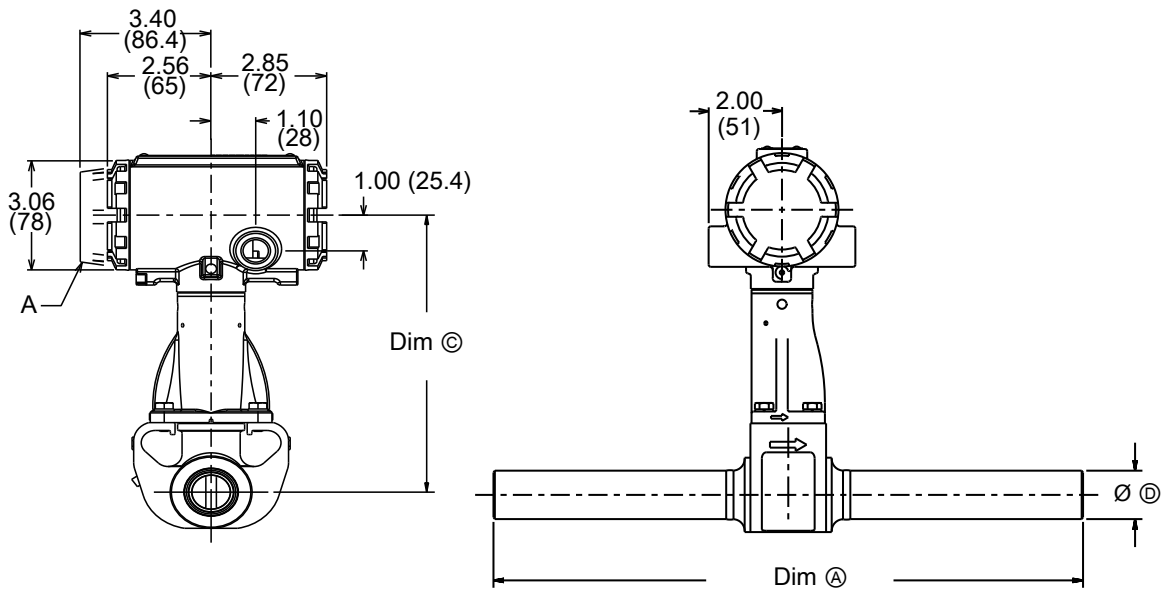

A Display option

Note

See Table 45 for Dim Ⓐ, Dim Ⓒ, and Ø Ⓑ values.

Table 45: Dimensions and weights for weld end style flow meter

| Nominal size in. (mm) | Pipe schedule | Dim Ⓐ inch (mm) | Dim Ⓞ inch (mm) | ØⓄ inch (mm) | Weight lb (kg) ⁽¹⁾ |
|-----------------------|-----------------|-----------------|-----------------|--------------|-------------------------------|
| 0.5 (15) | 10, 40, 160 | 16.0 (406) | 7.6 (194) | 0.84 (21.3) | 8 (4) |
| 1 (25) | 10, 40, 80, 160 | 16.0 (406) | 7.7 (197) | 1.32 (33.4) | 10 (5) |
| 1.5 (40) | 10, 40, 80, 160 | 16.0 (406) | 8.1 (207) | 1.90 (48.3) | 13 (6) |
| 2 (50) | 10, 40, 80 | 16.0 (406) | 8.5 (216) | 2.38 (60.3) | 15 (7) |
| | 160 | 16.0 (406) | 8.5 (216) | 2.38 (60.3) | 18 (8) |
| 3 (80) | 10, 40, 80 | 16.0 (406) | 9.1 (230) | 3.50 (88.9) | 24 (11) |
| | 160 | 16.0 (406) | 9.1 (230) | 3.50 (88.9) | 29 (13) |
| 4 (100) | 10, 40, 80 | 16.0 (406) | 9.6 (244) | 4.50 (114.3) | 32 (15) |
| | 160 | 16.0 (406) | 9.6 (244) | 4.50 (114.3) | 43 (19) |
| 6 (150) | 10, 40, 80 | 18.0 (457) | 10.8 (274) | 6.63 (168) | 60 (28) |
| | 160 | 18.0 (457) | 10.8 (274) | 6.63 (168) | 87 (40) |
| 8 (200) | 40, 80 | 18.0 (457) | 11.7 (297) | 8.63 (219) | 89 (40) |
| | 160 | 18.0 (457) | 11.7 (297) | 8.63 (219) | 144 (66) |
| 10 (250) | 40, 80, 160 | 20 (508) | 12.8 (325) | 10.75 (273) | 135 (61) |
| 12 (300) | 40, 80, 160 | 20 (508) | 13.7 (348) | 12.75 (324) | 185 (84.1) |

(1) With integral transmitter, and without MTA or CPA option.

Threaded end style flow meters

Figure 11: Dimensional drawing for threaded end style flow meters

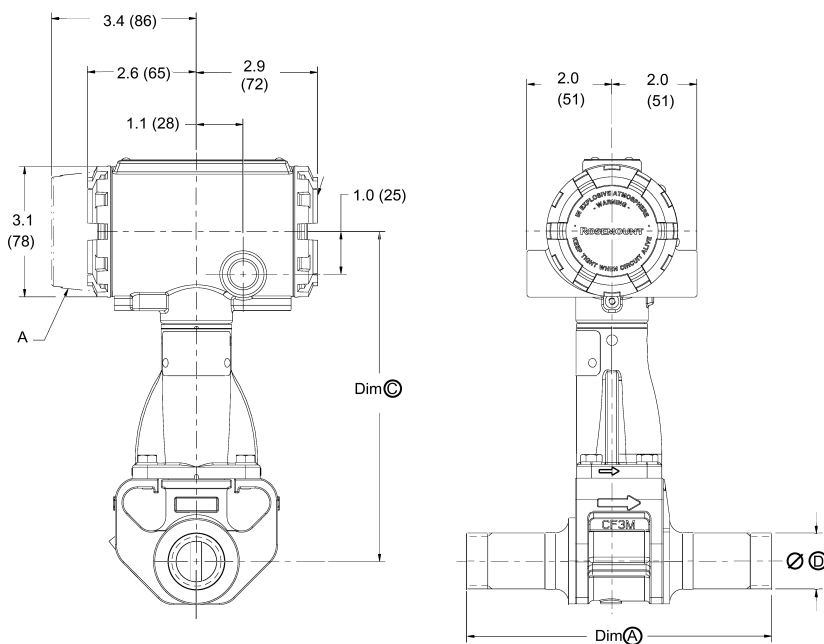

A Display option

Note

See Table 46 for Dim A, Dim C, and Ø values.

Table 46: Dimensions and weights for threaded end style flow meter

| Nominal size in. (mm) | Dim A inch (mm) | Dim C inch (mm) | Ø inch (mm) | Weight lb (kg) ⁽¹⁾ |
|-------------------------|-----------------|-----------------|-------------|-------------------------------|
| Straight thread | | | | |
| 0.5 (15) | 7.1 (180) | 7.6 (194) | .84 (21) | 7 (3) |
| 1 (25) | 7.1 (180) | 7.7 (197) | 1.3 (33) | 8 (4) |
| 1.5 (40) | 7.3 (186) | 8.1 (207) | 1.9 (48) | 11 (5) |
| 2 (50) | 10.0 (254) | 8.5 (216) | 2.4 (60) | 12 (6) |
| Threaded reducer | | | | |
| 1 (25) | 7.1 (180) | 7.6 (194) | 1.3 (33) | 9 (4) |
| 1.5 (40) | 7.3 (186) | 7.7 (197) | 1.9 (48) | 10 (5) |
| 2 (50) | 10.0 (254) | 8.1 (207) | 2.4 (60) | 14 (7) |

(1) With integral transmitter, and without MTA or CPA option.

Height variation and conduit entry with remote transmitters

Table 47 shows the location of the conduit entry and the adjusted height of the meter when a remote transmitter used.

Note

Dimension C is measured from the center of the process pipe, and is the same for all process fitting types.

Table 47: Height variation and conduit entry with remote transmitters

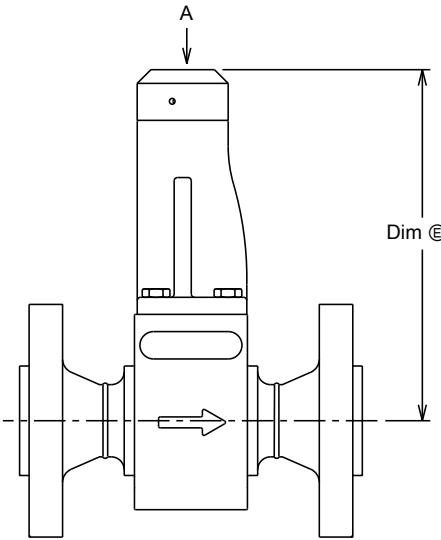
| | Meter size inch (mm) | Dim Ⓢ inch (mm) |
|---|----------------------|-----------------|
|  <p>A Conduit entry</p> <p>Dim Ⓢ Dimension to top of meter, add clearance for cable/fitting.</p> | ½ (15) | 6.4 (162) |
| | 1 (25) | 6.5 (165) |
| | 1½ (40) | 6.8 (173) |
| | 2 (50) | 7.2 (183) |
| | 3 (80) | 7.8 (198) |
| | 4 (100) | 8.3 (211) |
| | 6 (150) | 9.5 (241) |
| | 8 (200) | 10.4 (264) |
| | 10 (250) | 11.4 (290) |
| | 12 (300) | 12.3 (312) |

Clearance for MTA option

When the MTA option is selected, some additional clearance is required for the MTA sensor cable

Note

Dimension Ⓢ is measured from the center of the process pipe, and is the same for all process fitting types.

Table 48: Clearance for MTA option

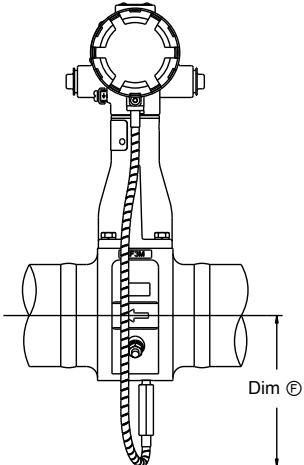
| | Meter size inch (mm) | Dim Ⓢ inch (mm) |
|---|----------------------|-----------------|
|  | 2 (50) | 4.5 (114) |
| | 3 (80) | 4.7 (119) |
| | 4 (100) | 5.3 (135) |
| | 6 (150) | 5.9 (150) |
| | 8 (200) | 7.4 (188) |
| | 10 (250) | 8.3 (211) |
| | 12 (300) | 9.3 (236) |
| | 14 (350) | 10.1 (256) |

Location for CPA valve option

When the CPA option is ordered, the CPA valve can be in one of three general locations depending on the size of the meter.

Note

On some models, the orientation or relative location of the CPA valve may vary. Contact an Emerson representative (see back page) for more precise information if needed.

Figure 12: Location for CPA valve option

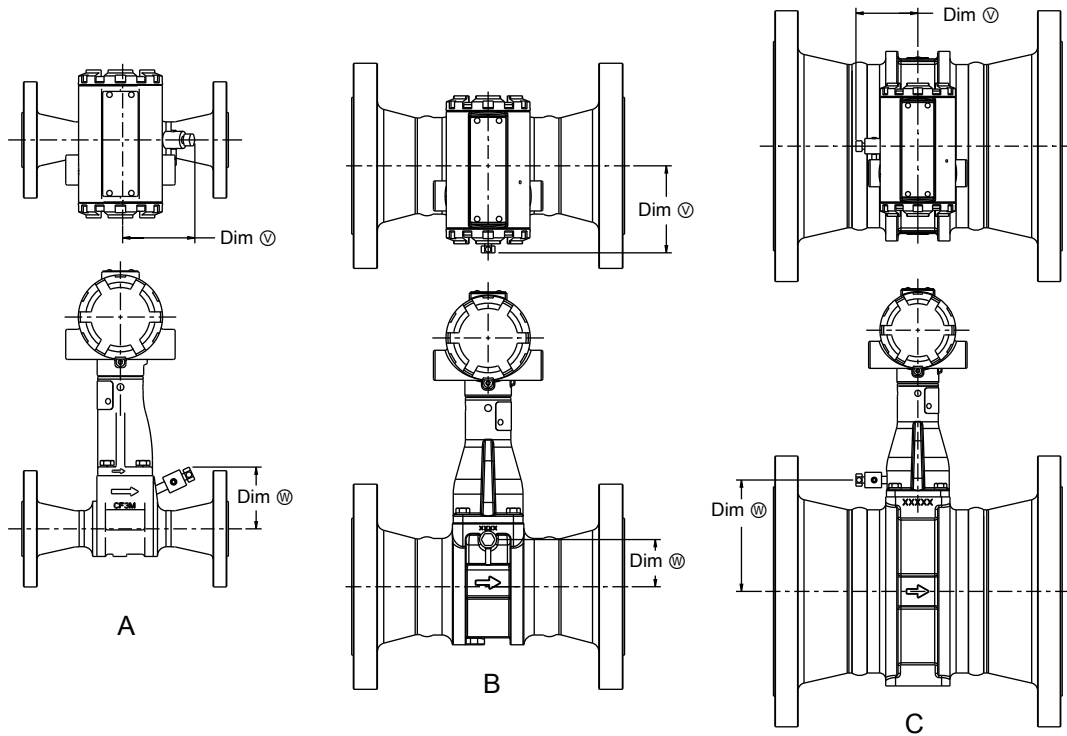

- A. 1–1½ inch (DN25–DN40) models and 1½–2 inch (DN40–DN50) reducer flange models
- B. 2–4 inch (DN50–DN100) models and 3–6 inch (DN80–DN150) reducer flange models
- C. 6+ inch (DN150+) models and 8+ inch (DN200) reducer flange models

Note

Dimensions ⑤ and ⑥ are measured from the center of the meter or process pipe, and they are the same for all process fitting types.

Table 49: Location for CPA valve option

| Meter size | Dim ∇ inch (mm) | Dim \circledast inch (mm) |
|--|--|---|
| 1 inch (DN25) (and 1½ inch [DN40] reducer) | 2.7 (70) | 2.3 (57) |
| 1½ inch (DN40) (and 2 inch [DN50] reducer) | 2.6 (66) | 2.6 (66) |
| 2 inch (DN50) (and 3 inch [DN80] reducer) | 3.2 (81) | 1.1 (28) |
| 3 inch (DN80) (and 4 inch [DN100] reducer) | 3.2 (81) | 1.7 (44) |
| 4 inch (DN100) (and 6 inch [DN150] reducer) | 3.2 (81) | 2.3 (57) |
| 6 inch (DN150) (and 8 inch [DN200] reducer) | 2.5 (64) | 4.5 (115) |
| 8 inch (DN200) (and 10 inch [DN250] reducer) | 2.5 (64) | 5.6 (141) |
| 10 inch (DN250) (and 12 inch [DN300] reducer) | 2.5 (64) | 6.6 (167) |
| 12 inch (DN300) (and 14 inch [DN350] reducer) | 2.5 (64) | 7.5 (190) |

Dual transmitter dimensions

Figure 13: Vortex Dual-Sensor Style Flowmeter (1/2- through 4-in./15 mm through 100 mm Line Sizes)

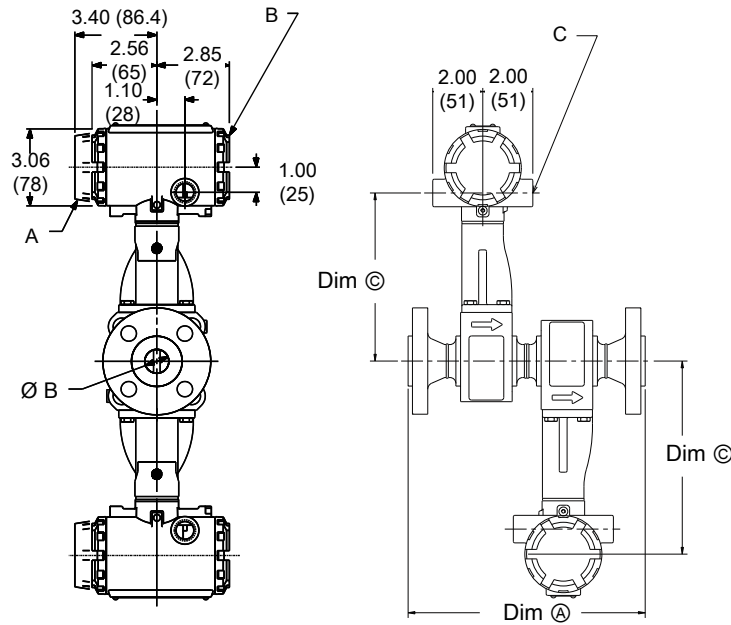

- A. Display option
- B. Terminal cover
- C. Electrical connection

Note

For Dim A, Dim ØB, and Dim C, see Table 50 and Table 51 for dimensions.

Figure 14: Vortex Dual-Sensor Style Flowmeter (6- through 12-in./150 mm through 300 mm Line Sizes)

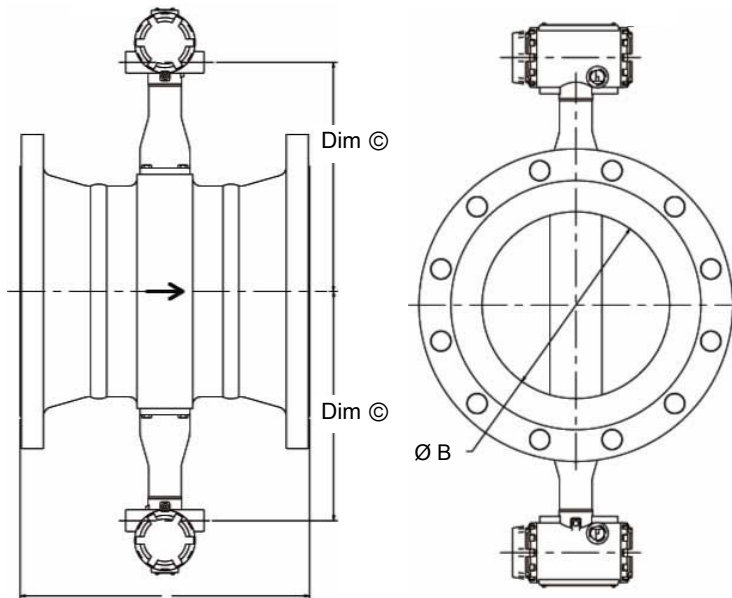

Note

For Dim ØB and Dim C, see Table 50 and Table 51 for dimensions.

Table 50: Vortex Dual-Sensor Style Flowmeter (1/2- through 4-in./15 mm through 100 mm Line Sizes)

| Nominal size inch (mm) | Flange rating | Face-to-face Dim [Ⓐ] inch (mm) | Dim [Ⓐ] RTJ inch (mm) | Dim [Ⓢ] [Ⓢ] inch (mm) | Dim [Ⓢ] inch (mm) | Weight lb (kg) |
|---------------------------|---------------|---|-----------------------------------|--|-------------------------------|----------------|
| ½ (15) | Class 150 | 11.9 (302) | N/A | 0.54 (13,7) | 7.6 (193) | 16 (7) |
| | Class 300 | 12.3 (312) | 12.6 (320) | 0.54 (13,7) | 7.6 (193) | 17 (8) |
| | Class 600 | 12.8 (325) | 12.7 (323) | 0.54 (13,7) | 7.6 (193) | 18 (8) |
| | Class 900 | 13.4 (340) | 13.4 (340) | 0.54 (13,7) | 7.6 (193) | 23 (10) |
| | PN 16/40 | 11.2 (284) | N/A | 0.54 (13,7) | 7.6 (193) | 17 (8) |
| | PN 100 | 11.7 (297) | N/A | 0.54 (13,7) | 7.6 (193) | 19 (9) |
| 1 (25) | JIS 10K/20K | 11.4 (290) | N/A | 0.54 (13,7) | 7.6 (193) | 17 (8) |
| | JIS 40K | 12.4 (315) | N/A | 0.54 (13,7) | 7.6 (193) | 21 (9) |
| | Class 150 | 15.0 (381) | 15.4 (391) | 0.95 (24,1) | 7.7 (196) | 21 (9) |
| | Class 300 | 15.6 (396) | 15.9 (404) | 0.95 (24,1) | 7.7 (196) | 23 (11) |
| | Class 600 | 16.1 (409) | 16.1 (409) | 0.95 (24,1) | 7.7 (196) | 24 (11) |
| | Class 900 | 16.9 (429) | 16.9 (429) | 0.95 (24,1) | 7.7 (196) | 33 (15) |
| 1½ (40) | Class 1500 | 16.9 (429) | 16.9 (429) | 0.95 (24,1) | 7.7 (196) | 33 (15) |
| | PN 16/40 | 13.8 (351) | N/A | 0.95 (24,1) | 7.7 (196) | 22 (10) |
| | PN 100 | 15.3 (389) | N/A | 0.95 (24,1) | 7.7 (196) | 28 (13) |
| | PN 160 | 15.3 (389) | N/A | 0.95 (24,1) | 7.7 (196) | 28 (13) |
| | JIS 10K/20K | 14.0 (356) | N/A | 0.95 (24,1) | 7.7 (196) | 22 (10) |
| | JIS 40K | 15.4 (391) | N/A | 0.95 (24,1) | 7.7 (196) | 26 (12) |
| 2 (50) | Class 150 | 11.3 (287) | 11.7 (297) | 1.49 (37,8) | 8.1 (206) | 27 (12) |
| | Class 300 | 11.8 (300) | 12.2 (310) | 1.49 (37,8) | 8.1 (206) | 32 (15) |
| | Class 600 | 12.4 (315) | 12.4 (315) | 1.49 (37,8) | 8.1 (206) | 35 (16) |
| | Class 900 | 13.4 (340) | 13.4 (340) | 1.49 (37,8) | 8.1 (206) | 46 (21) |
| | Class 1500 | 13.4 (340) | 13.4 (340) | 1.49 (37,8) | 8.1 (206) | 46 (21) |
| | PN 16/40 | 9.9 (251) | N/A | 1.49 (37,8) | 8.1 (206) | 29 (13) |
| 2 (50) | PN 100 | 11.3 (287) | N/A | 1.49 (37,8) | 8.1 (206) | 37 (17) |
| | PN 160 | 11.4 (290) | N/A | 1.49 (37,8) | 8.1 (206) | 39 (18) |
| | JIS 10K/20K | 10.3 (262) | N/A | 1.49 (37,8) | 8.1 (206) | 28 (13) |
| | JIS 40K | 11.5 (292) | N/A | 1.49 (37,8) | 8.1 (206) | 35 (16) |
| | Class 150 | 13.0 (330) | 13.4 (340) | 1.92 (48,8) | 8.5 (216) | 32 (15) |
| | Class 300 | 13.5 (343) | 14.0 (356) | 1.92 (48,8) | 8.5 (216) | 36 (16) |
| 2 (50) | Class 600 | 14.3 (363) | 14.4 (366) | 1.92 (48,8) | 8.5 (216) | 39 (18) |
| | Class 900 | 16.5 (419) | 16.7 (424) | 1.92 (48,8) | 8.5 (216) | 69 (31) |
| | Class 1500 | 17.0 (432) | 17.2 (437) | 1.67 (42,4) | 8.5 (216) | 72 (33) |
| | PN 16/40 | 11.8 (300) | N/A | 1.92 (48,8) | 8.5 (216) | 33 (15) |
| | PN 63/64 | 12.9 (328) | N/A | 1.92 (48,8) | 8.5 (216) | 40 (18) |
| | PN 100 | 13.4 (340) | N/A | 1.92 (48,8) | 8.5 (216) | 46 (21) |
| 2 (50) | PN 160 | 13.9 (353) | N/A | 1.92 (48,8) | 8.5 (216) | 48 (22) |
| | JIS 10K | 11.5 (292) | N/A | 1.92 (48,8) | 8.5 (216) | 29 (13) |
| | JIS 20K | 12.0 (305) | N/A | 1.92 (48,8) | 8.5 (216) | 30 (14) |
| | JIS 40K | 13.6 (345) | N/A | 1.92 (48,8) | 8.5 (216) | 38 (14) |

Table 50: Vortex Dual-Sensor Style Flowmeter (1/2- through 4-in./15 mm through 100 mm Line Sizes) (continued)

| Nominal size inch (mm) | Flange rating | Face-to-face Dim [Ⓐ] inch (mm) | Dim [Ⓐ] RTJ inch (mm) | Dim [Ⓢ] inch (mm) | Dim [Ⓒ] inch (mm) | Weight lb (kg) | |
|------------------------|---------------|---|--------------------------------|----------------------------|----------------------------|----------------|---------|
| 3 (80) | Class 150 | 14.3 (363) | 14.7 (373) | 2.87 (72,9) | 9.1 (231) | 51 (23) | |
| | Class 300 | 15.0 (381) | 15.5 (394) | 2.87 (72,9) | 9.1 (231) | 60 (27) | |
| | Class 600 | 15.8 (401) | 15.9 (404) | 2.87 (72,9) | 9.1 (231) | 66 (30) | |
| | Class 900 | 17.3 (439) | 17.4 (442) | 2.87 (72,9) | 9.1 (231) | 88 (41) | |
| | Class 1500 | 18.5 (470) | 18.7 (475) | 2.60 (66.0) | 9.1 (232) | 124 (56) | |
| | PN 16/40 | 13.4 (340) | N/A | 2.87 (72,9) | 9.1 (231) | 50 (23) | |
| | PN 63/64 | 14.5 (367) | N/AN/A | 2.87 (72,9) | 9.1 (231) | 59 (27) | |
| | PN 100 | 14.9 (378) | N/A | 2.87 (72,9) | 9.1 (231) | 68 (31) | |
| | PN 160 | 15.6 (396) | N/A | 2.87 (72,9) | 9.1 (231) | 73 (33) | |
| | JIS 10K | 12.3 (312) | N/A | 2.87 (72,9) | 9.1 (231) | 41 (19) | |
| | JIS 20K | 13.7 (348) | N/A | 2.87 (72,9) | 9.1 (231) | 49 (22) | |
| | JIS 40K | 15.5 (394) | N/A | 2.87 (72,9) | 9.1 (231) | 64 (29) | |
| | 4 (100) | Class 150 | 15.2 (386) | 15.6 (396) | 3.79 (96,3) | 9.6 (244) | 70 (32) |
| | | Class 300 | 16.0 (406) | 16.5 (419) | 3.79 (96,3) | 9.6 (244) | 89 (41) |
| Class 600 | | 17.7 (450) | 17.9 (455) | 3.79 (96,3) | 9.6 (244) | 116 (53) | |
| Class 900 | | 18.7 (475) | 18.9 (480) | 3.79 (96,3) | 9.6 (244) | 139 (63) | |
| Class 1500 | | 20.0 (509) | 20.2 (513) | 3.40 (86.4) | 9.6 (244) | 184 (83) | |
| PN 16 | | 13.3 (338) | N/A | 3.79 (96,3) | 9.6 (244) | 59 (27) | |
| PN 40 | | 14.4 (366) | N/A | 3.79 (96,3) | 9.6 (244) | 68 (31) | |
| PN 63/64 | | 15.4 (391) | N/A | 3.79 (96,3) | 9.6 (244) | 81 (37) | |
| PN 100 | | 16.3 (414) | N/A | 3.79 (96,3) | 9.6 (244) | 97 (44) | |
| PN 160 | | 17.1 (434) | N/A | 3.79 (96,3) | 9.6 (244) | 104 (47) | |
| JIS 10K | | 13.6 (345) | N/A | 3.79 (96,3) | 9.6 (244) | 56 (25) | |
| JIS 20K | | 13.6 (345) | N/A | 3.79 (96,3) | 9.6 (244) | 64 (29) | |
| JIS 40K | | 16.8 (427) | N/A | 3.79 (96,3) | 9.6 (244) | 94 (43) | |

Table 51: Vortex Dual-Sensor Style Flowmeter (6- through 12-in./150 mm through 300 mm Line Sizes)

| Nominal size inch (mm) | Flange rating | Face-to-face Dim [Ⓐ] inch (mm) | Dim [Ⓐ] RTJ inch (mm) | Dim [Ⓢ] inch (mm) | Dim [Ⓒ] inch (mm) | Weight lb (kg) |
|------------------------|---------------|---|--------------------------------|----------------------------|----------------------------|----------------|
| 6 (150) | Class 150 | 11.6 (295) | 12.0 (305) | 5.7 (144,8) | 10.8 (274) | 85 (39) |
| | Class 300 | 12.3 (312) | 12.8 (325) | 5.7 (144,8) | 10.8 (274) | 124 (57) |
| | Class 600 | 14.3 (363) | 14.4 (366) | 5.7 (144,8) | 10.8 (274) | 191 (87) |
| | Class 900 | 16.1 (409) | 16.2 (411) | 5.14 (130.6) | 10.8 (274) | 282 (128) |
| | Class 1500 | 18.6 (472) | 18.8 (478) | 5.14 (130.6) | 10.8 (274) | 380 (173) |
| | PN 16 | 8.9 (226) | N/A | 5.7 (144,8) | 10.8 (274) | 70 (32) |
| | PN 40 | 10.5 (267) | N/A | 5.7 (144,8) | 10.8 (274) | 90 (41) |
| | PN 63/64 | 12.1 (307) | N/A | 5.7 (144,8) | 10.8 (274) | 134 (61) |
| | PN 100 | 13.6 (345) | N/A | 5.7 (144,8) | 10.8 (274) | 164 (75) |

Table 51: Vortex Dual-Sensor Style Flowmeter (6- through 12-in./150 mm through 300 mm Line Sizes) (continued)

| Nominal size inch (mm) | Flange rating | Face-to-face Dim [Ⓐ] inch (mm) | Dim [Ⓐ] RTJ inch (mm) | Dim [Ⓑ] inch (mm) | Dim [Ⓒ] inch (mm) | Weight lb (kg) | |
|---------------------------|---------------|---|-----------------------------------|-------------------------------|-------------------------------|----------------|-----------|
| | JIS 10K | 10.6 (269) | N/A | 5.7 (144,8) | 10.8 (274) | 74 (34) | |
| | JIS 20K | 10.6 (269) | N/A | 5.7 (144,8) | 10.8 (274) | 92 (42) | |
| | JIS 40K | 14.2 (361) | N/A | 5.7 (144,8) | 10.8 (274) | 170 (77) | |
| 8 (200) | Class 150 | 13.5 (343) | 13.9 (353) | 7.55 (191,8) | 11.7 (297) | 146 (66) | |
| | Class 300 | 14.3 (363) | 14.8 (376) | 7.55 (191,8) | 11.7 (297) | 203 (92) | |
| | Class 600 | 16.5 (419) | 16.7 (424) | 7.55 (191,8) | 11.7 (297) | 303 (138) | |
| | Class 900 | 18.8 (478) | 18.9 (480) | 6.62 (168,1) | 11.7 (297) | 484 (220) | |
| | Class 1500 | 22.8 (580) | 23.2 (589) | 6.62 (168,1) | 11.7 (297) | 657 (299) | |
| | PN 10 | 10.4 (264) | N/A | 7.55 (191,8) | 11.7 (297) | 115 (52) | |
| | PN 16 | 10.4 (264) | N/A | 7.55 (191,8) | 11.7 (297) | 114 (52) | |
| | PN 25 | 11.8 (300) | N/A | 7.55 (191,8) | 11.7 (297) | 142 (65) | |
| | PN 40 | 12.5 (318) | N/A | 7.55 (191,8) | 11.7 (297) | 161 (73) | |
| | PN 63/64 | 14.2 (361) | N/A | 7.55 (191,8) | 11.7 (297) | 221 (101) | |
| | PN 100 | 15.8 (401) | N/A | 7.55 (191,8) | 11.7 (297) | 287 (130) | |
| | JIS 10K | 12.2 (310) | N/A | 7.55 (191,8) | 11.7 (297) | 114 (52) | |
| | JIS 20K | 12.2 (310) | N/A | 7.55 (191,8) | 11.7 (297) | 139 (63) | |
| | JIS 40K | 16.5 (419) | N/A | 7.55 (191,8) | 11.7 (297) | 260 (118) | |
| | 10 (250) | Class 150 | 14.5 (368) | 14.9 (378) | 9.56 (243) | 12.8 (325) | 202 (92) |
| Class 300 | | 15.8 (401) | 16.3 (414) | 9.56 (243) | 12.8 (325) | 290 (132) | |
| Class 600 | | 19.0 (483) | 19.2 (488) | 9.56 (243) | 12.8 (325) | 482 (219) | |
| PN 10 | | 11.9 (302) | N/A | 9.56 (243) | 12.8 (325) | 161 (73) | |
| PN 16 | | 12.0 (305) | N/A | 9.56 (243) | 12.8 (325) | 166 (75) | |
| PN 25 | | 13.5 (343) | N/A | 9.56 (243) | 12.8 (325) | 203 (92) | |
| PN 40 | | 14.8 (376) | N/A | 9.56 (243) | 12.8 (325) | 251 (114) | |
| PN 63/64 | | 16.4 (417) | N/A | 9.56 (243) | 12.8 (325) | 312 (142) | |
| PN 100 | | 18.9 (480) | N/A | 9.56 (243) | 12.8 (325) | 450 (204) | |
| JIS 10K | | 14.5 (368) | N/A | 9.56 (243) | 12.8 (325) | 179 (81) | |
| JIS 20K | | 14.5 (368) | N/A | 9.56 (243) | 12.8 (325) | 226 (103) | |
| JIS 40K | | 18.1 (460) | N/A | 9.56 (243) | 12.8 (325) | 383 (174) | |
| 12 (300) | | Class 150 | 16.8 (427) | 17.1 (434) | 11.38 (289) | 13.7 (348) | 302 (137) |
| | | Class 300 | 18.0 (457) | 18.5 (470) | 11.38 (289) | 13.7 (348) | 420 (191) |
| | | Class 600 | 20.5 (521) | 20.6 (523) | 11.38 (289) | 13.7 (348) | 600 (272) |
| | PN 10 | 13.1 (331) | N/A | 11.38 (289) | 13.7 (348) | 208 (95) | |
| | PN 16 | 13.9 (353) | N/A | 11.38 (289) | 13.7 (348) | 229 (104) | |
| | PN 25 | 15.0 (381) | N/A | 11.38 (289) | 13.7 (348) | 274 (124) | |
| | PN 40 | 16.8 (427) | N/A | 11.38 (289) | 13.7 (348) | 352 (160) | |
| | PN 63/64 | 18.8 (478) | N/A | 11.38 (289) | 13.7 (348) | 435 (198) | |
| | PN 100 | 21.2 (538) | N/A | 11.38 (289) | 13.7 (348) | 648 (294) | |
| | JIS 10K | 15.7 (399) | N/A | 11.38 (289) | 13.7 (348) | 227 (103) | |
| | JIS 20K | 15.7 (399) | N/A | 11.38 (289) | 13.7 (348) | 288 (131) | |
| | JIS 40K | 19.6 (498) | N/A | 11.38 (289) | 13.7 (348) | 498 (226) | |

Figure 15: Dual Sensor Flanged-Style Remote Mount Flowmeters (1/2- through 12-inch/15 mm through 300 mm Line Sizes)

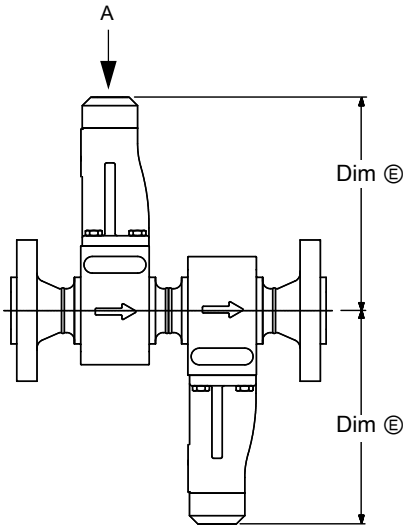

A. 1/2-14 NPT (for remote cable conduit)

Note

For Dim Ⓢ, see [Table 52](#).

Table 52: Remote Mount Flanged, Dual Sensor Flowmeter Dimensions

| Nominal size inch (mm) | Dim Ⓢ inch (mm) |
|------------------------|-----------------|
| 1/2 (15) | 6.4 (162) |
| 1 (25) | 6.5 (165) |
| 1 1/2 (40) | 6.8 (173) |
| 2 (50) | 7.2 (183) |
| 3 (80) | 7.8 (198) |
| 4 (100) | 8.3 (211) |
| 6 (150) | 9.5 (241) |
| 8 (200) | 10.4 (264) |
| 10 (250) | 11.4 (290) |
| 12 (300) | 12.3 (313) |

Location for CPA valve option

When the CPA option is ordered, the CPA valve can be in one of three general locations depending on the size of the meter.

Note

On some models, the orientation or relative location of the CPA valve may vary. Contact an Emerson representative (see back page) for more precise information if needed.

Figure 16: Location for CPA valve option

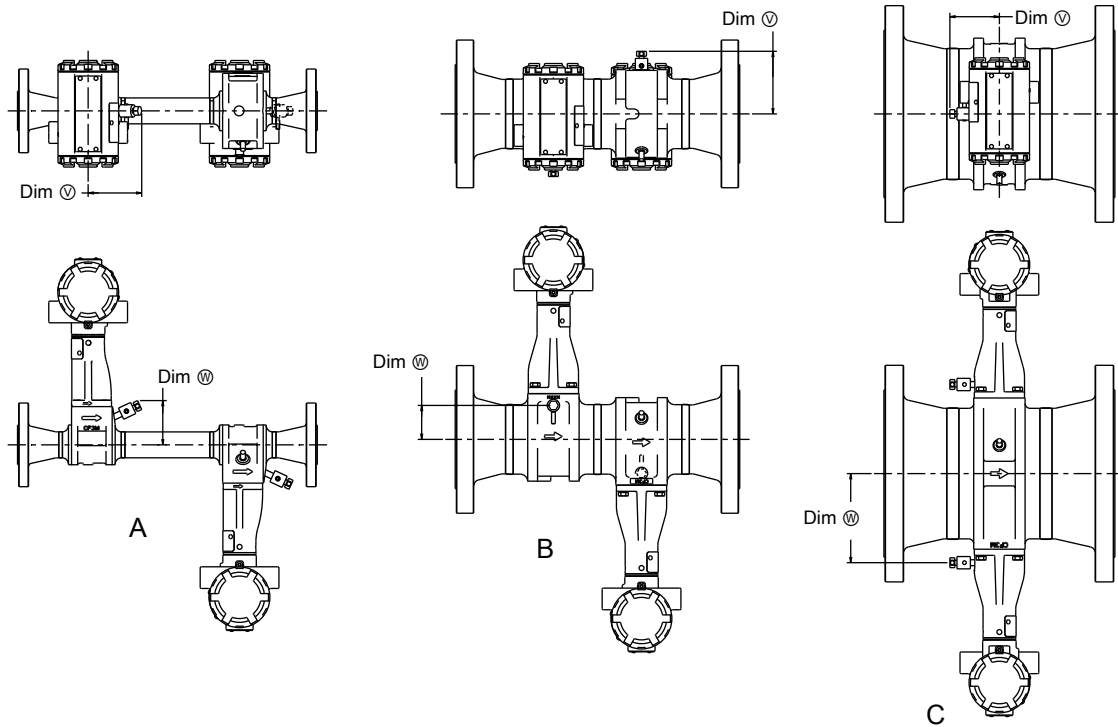

- A. 1–1½ inch (DN25–DN40) models
- B. 2–4 inch (DN50–DN100) models
- C. 6+ inch (DN150+) models

Note

Dimensions ∅ and ⊕ are measured from the center of the meter or process pipe, and they are the same for all process fitting types.

Table 53: Location for CPA valve option

| Meter size | Dim ∅ inch (mm) | Dim ⊕ inch (mm) |
|-----------------|-----------------|-----------------|
| 1 inch (DN25) | 2.7 (70) | 2.3 (57) |
| 1½ inch (DN40) | 2.6 (66) | 2.6 (66) |
| 2 inch (DN50) | 3.2 (81) | 1.1 (28) |
| 3 inch (DN80) | 3.2 (81) | 1.7 (44) |
| 4 inch (DN100) | 3.2 (81) | 2.3 (57) |
| 6 inch (DN150) | 2.5 (64) | 4.5 (115) |
| 8 inch (DN200) | 2.5 (64) | 5.6 (141) |
| 10 inch (DN250) | 2.5 (64) | 6.6 (167) |
| 12 inch (DN300) | 2.5 (64) | 7.5 (190) |

Quad transmitter dimensions

Figure 17: Vortex quad sensor for remote transmitters, all line sizes

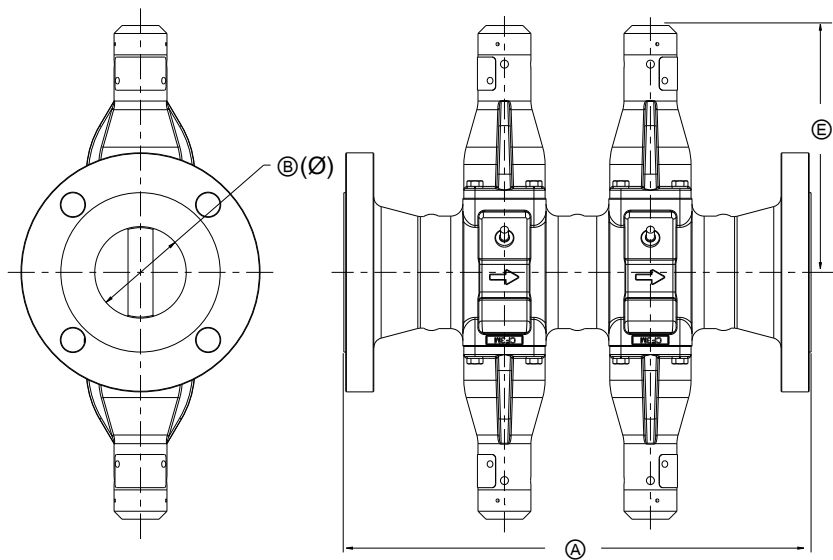

- A. Face-to-face dimension Ⓐ
- B. Inside diameter Ⓟ
- C. Center-to-top/bottom dimension Ⓒ

Note

For product weight and dimensions, see [Table 54](#).

Figure 18: Vortex integral quad meters, 6 inch through 12 inch (150 mm through 300 mm) line sizes

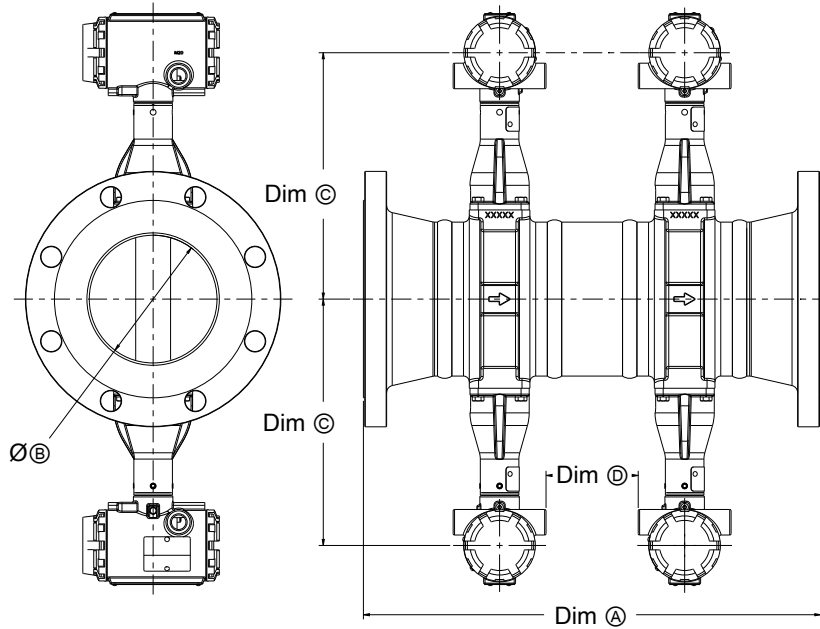

Note
For product weight and Dims \textcircled{A} , \textcircled{B} , \textcircled{C} , and \textcircled{D} , see Table 54.

Note
For 4 inch (DN100) and smaller meters, weights do not include the remote transmitter. For 6 inch (DN150) and larger meters, weights include integral transmitters. To determine the weight for 6 inch (DN150) and larger meters without integral transmitters, subtract a total of 10 lb (4.6 kg).

Table 54: Vortex quad sensor flow meter for integral or remote transmitters, dimensions for 2 inch to 12 inch (50 mm through 300 mm) line sizes

| Nominal size, inch (mm) | Flange rating | Face-to-face Dim \textcircled{A} , inch (mm) | | Dim \textcircled{B} , inch (mm) | Dim \textcircled{C} , inch (mm) | Dim \textcircled{D} , inch (mm) | Dim \textcircled{E} , inch (mm) | Weight, lb (kg) |
|-------------------------|---------------|--|------------|-----------------------------------|-----------------------------------|-----------------------------------|-----------------------------------|-----------------|
| | | Flanged | RTJ | | | | | |
| 2 inch (DN50) | 150 | 12.6 (320) | 12.9 (328) | 1.9 (49) | - | - | 7.2 (183) | 31 (14) |
| | 300 | 13.1 (333) | 13.6 (345) | 1.9 (49) | - | - | 7.2 (183) | 35 (16) |
| | 600 | 13.8 (351) | 13.9 (353) | 1.9 (49) | - | - | 7.2 (183) | 39 (18) |
| | 900 | 16.1 (409) | 16.2 (411) | 1.9 (49) | - | - | 7.2 (183) | 68 (31) |
| | 1500 | 15.6 (396) | 15.7 (399) | 1.7 (42) | - | - | 7.2 (183) | 72 (33) |
| | PN16 | 11.1 (282) | - | 1.9 (49) | - | - | 7.2 (183) | 31 (14) |
| | PN40 | 11.3 (287) | - | 1.9 (49) | - | - | 7.2 (183) | 32 (14) |
| | PN63 | 12.4 (315) | - | 1.9 (49) | - | - | 7.2 (183) | 40 (18) |
| | PN100 | 12.9 (328) | - | 1.9 (49) | - | - | 7.2 (183) | 45 (20) |
| | PN160 | 13.5 (343) | - | 1.9 (49) | - | - | 7.2 (183) | 48 (22) |
| | JIS 10K | 11 (279) | - | 1.9 (49) | - | - | 7.2 (183) | 31 (14) |
| | JIS 20K | 11.6 (295) | - | 1.9 (49) | - | - | 7.2 (183) | 35 (16) |

Table 54: Vortex quad sensor flow meter for integral or remote transmitters, dimensions for 2 inch to 12 inch (50 mm through 300 mm) line sizes (continued)

| Nominal size, inch (mm) | Flange rating | Face-to-face Dim [Ⓐ] , inch (mm) | | Dim [Ⓑ] , inch (mm) | Dim [Ⓒ] , inch (mm) | Dim [Ⓓ] , inch (mm) | Dim [Ⓔ] , inch (mm) | Weight, lb (kg) |
|-------------------------|---------------|---|------------|------------------------------|------------------------------|------------------------------|------------------------------|-----------------|
| | | Flanged | RTJ | | | | | |
| | JIS 40K | 13.1 (333) | - | 1.9 (49) | - | - | 7.2 (183) | 39 (18) |
| 3 inch (DN80) | 150 | 14.3 (363) | 14.7 (373) | 2.9 (73) | - | - | 7.8 (198) | 50 (23) |
| | 300 | 15 (381) | 15.5 (394) | 2.9 (73) | - | - | 7.8 (198) | 59 (27) |
| | 600 | 15.8 (401) | 15.9 (404) | 2.9 (73) | - | - | 7.8 (198) | 66 (30) |
| | 900 | 17.3 (439) | 17.4 (442) | 2.9 (73) | - | - | 7.8 (198) | 89 (40) |
| | 1500 | 18.4 (467) | 18.6 (472) | 2.6 (66) | - | - | 7.8 (198) | 122 (56) |
| | PN 16 | 12.7 (323) | - | 2.9 (73) | - | - | 7.8 (198) | 46 (21) |
| | PN 40 | 13.4 (340) | - | 2.9 (73) | - | - | 7.8 (198) | 50 (23) |
| | PN 63 | 14.5 (368) | - | 2.9 (73) | - | - | 7.8 (198) | 59 (27) |
| | PN100 | 14.9 (378) | - | 2.9 (73) | - | - | 7.8 (198) | 68 (31) |
| | PN160 | 15.6 (396) | - | 2.9 (73) | - | - | 7.8 (198) | 73 (33) |
| | JIS 10K | 12.3 (312) | - | 2.9 (73) | - | - | 7.8 (198) | 50 (23) |
| | JIS 20K | 13.7 (348) | - | 2.9 (73) | - | - | 7.8 (198) | 59 (27) |
| JIS 40K | 15.4 (391) | - | 2.9 (73) | - | - | 7.8 (198) | 66 (30) | |
| 4 inch (DN100) | 150 | 15.3 (389) | 15.6 (396) | 3.8 (96) | - | - | 8.3 (211) | 70 (32) |
| | 300 | 16 (406) | 16.5 (419) | 3.8 (96) | - | - | 8.3 (211) | 90 (41) |
| | 600 | 17.8 (452) | 17.9 (455) | 3.8 (96) | - | - | 8.3 (211) | 116 (53) |
| | 900 | 18.8 (478) | 18.9 (480) | 3.8 (96) | - | - | 8.3 (211) | 139 (63) |
| | 1500 | 20.0 (508) | 20.1 (511) | 3.4 (86) | - | - | 8.3 (211) | 188 (86) |
| | PN16 | 13.4 (340) | - | 3.8 (96) | - | - | 8.3 (211) | 60 (27) |
| | PN40 | 14.4 (366) | - | 3.8 (96) | - | - | 8.3 (211) | 69 (31) |
| | PN63 | 15.4 (391) | - | 3.8 (96) | - | - | 8.3 (211) | 82 (37) |
| | PN100 | 16.3 (414) | - | 3.8 (96) | - | - | 8.3 (211) | 99 (45) |
| | PN160 | 17.1 (434) | - | 3.8 (96) | - | - | 8.3 (211) | 106 (48) |
| | JIS 10K | 13.7 (348) | - | 3.8 (96) | - | - | 8.3 (211) | 70 (32) |
| | JIS 20K | 13.7 (348) | - | 3.8 (96) | - | - | 8.3 (211) | 90 (41) |
| JIS 40K | 16.8 (427) | - | 3.8 (96) | - | - | 8.3 (211) | 116 (53) | |
| 6 inch (DN150) | 150 | 19.3 (490) | 19.6 (498) | 5.7 (145) | 10.8 (274) | 3.8 (95) | 9.5 (241) | 128 (58) |
| | 300 | 20.0 (508) | 20.5 (521) | 5.7 (145) | 10.8 (274) | 3.8 (95) | 9.5 (241) | 168 (76) |
| | 600 | 22.0 (559) | 22.1 (561) | 5.7 (145) | 10.8 (274) | 3.8 (95) | 9.5 (241) | 234 (106) |
| | 900 | 23.3 (592) | 23.5 (597) | 5.7 (145) | 10.8 (274) | 3.8 (95) | 9.5 (241) | 333 (151) |
| | 1500 | 25.8 (663) | 26.1 (663) | 5.1 (131) | 10.8 (274) | 3.4 (86) | 9.5 (241) | 432 (196) |
| | PN16 | 16.6 (422) | - | 5.7 (145) | 10.8 (274) | 3.8 (95) | 9.5 (241) | 114 (52) |

Table 54: Vortex quad sensor flow meter for integral or remote transmitters, dimensions for 2 inch to 12 inch (50 mm through 300 mm) line sizes (continued)

| Nominal size, inch (mm) | Flange rating | Face-to-face Dim [Ⓐ] , inch (mm) | | Dim [Ⓞ] , inch (mm) | Dim [Ⓒ] , inch (mm) | Dim [Ⓓ] , inch (mm) | Dim [Ⓔ] , inch (mm) | Weight, lb (kg) |
|-------------------------|---------------|---|------------|------------------------------|------------------------------|------------------------------|------------------------------|-----------------|
| | | Flanged | RTJ | | | | | |
| | PN40 | 18.2 (462) | - | 5.7 (145) | 10.8 (274) | 3.8 (95) | 9.5 (241) | 134 (61) |
| | PN63 | 19.7 (500) | - | 5.7 (145) | 10.8 (274) | 3.8 (95) | 9.5 (241) | 178 (81) |
| | PN100 | 21.3 (541) | - | 5.7 (145) | 10.8 (274) | 3.8 (95) | 9.5 (241) | 208 (94) |
| | PN160 | 21.9 (556) | - | 5.1 (131) | 10.8 (274) | 3.4 (86) | 9.5 (241) | 270 (123) |
| | JIS10K | 18.3 (465) | - | 5.7 (145) | 10.8 (274) | 3.8 (95) | 9.5 (241) | 128 (58) |
| | JIS20K | 18.3 (465) | - | 5.7 (145) | 10.8 (274) | 3.8 (95) | 9.5 (241) | 168 (76) |
| | JIS40K | 21.8 (554) | - | 5.7 (145) | 10.8 (274) | 3.8 (95) | 9.5 (241) | 234 (106) |
| 8 inch (DN200) | 150 | 23.9 (607) | 24.3 (617) | 7.6 (192) | 11.7 (297) | 6.4 (126) | 10.4 (264) | 207 (94) |
| | 300 | 24.6 (625) | 25.1 (638) | 7.6 (192) | 11.7 (297) | 6.4 (126) | 10.4 (264) | 264 (120) |
| | 600 | 26.9 (683) | 27.0 (686) | 7.6 (192) | 11.7 (297) | 6.4 (126) | 10.4 (264) | 363 (165) |
| | 900 | 27.6 (701) | 27.8 (706) | 6.6 (168) | 11.7 (297) | 5.0 (126) | 10.4 (264) | 590 (268) |
| | 1500 | 31.6 (829) | 32.0 (813) | 6.6 (168) | 11.7 (297) | 5.0 (126) | 10.4 (264) | 763 (346) |
| | PN10 | 20.8 (528) | - | 7.6 (192) | 11.7 (297) | 6.4 (126) | 10.4 (264) | 177 (80) |
| | PN16 | 20.8 (528) | - | 7.6 (192) | 11.7 (297) | 6.4 (126) | 10.4 (264) | 176 (80) |
| | PN25 | 22.2 (564) | - | 7.6 (192) | 11.7 (297) | 6.4 (126) | 10.4 (264) | 205 (93) |
| | PN40 | 22.8 (579) | - | 7.6 (192) | 11.7 (297) | 6.4 (126) | 10.4 (264) | 223 (101) |
| | PN63 | 24.5 (623) | - | 7.6 (192) | 11.7 (297) | 6.4 (126) | 10.4 (264) | 284 (129) |
| | PN100 | 26.1 (663) | - | 7.6 (192) | 11.7 (297) | 6.4 (126) | 10.4 (264) | 350 (159) |
| | PN160 | 25.4 (645) | - | 6.6 (168) | 11.7 (297) | 5.0 (126) | 10.4 (264) | 491 (223) |
| | JIS10K | 22.5 (572) | - | 7.6 (192) | 11.7 (297) | 6.4 (126) | 10.4 (264) | 207 (94) |
| | JIS20K | 22.5 (572) | - | 7.6 (192) | 11.7 (297) | 6.4 (126) | 10.4 (264) | 264 (120) |
| JIS40K | 26.8 (682) | - | 7.6 (192) | 11.7 (297) | 6.4 (126) | 10.4 (264) | 363 (165) | |
| 10 inch (DN250) | 150 | 27.9 (709) | 28.3 (719) | 9.6 (243) | 12.8 (325) | 9.4 (239) | 11.5 (292) | 309 (140) |
| | 300 | 29.1 (739) | 29.6 (752) | 9.6 (243) | 12.8 (325) | 9.4 (239) | 11.5 (292) | 270 (123) |
| | 600 | 32.4 (823) | 32.5 (826) | 9.6 (243) | 12.8 (325) | 9.4 (239) | 11.5 (292) | 588 (267) |
| | PN10 | 25.2 (640) | - | 9.6 (243) | 12.8 (325) | 9.4 (239) | 11.5 (292) | 270 (123) |
| | PN16 | 25.4 (645) | - | 9.6 (243) | 12.8 (325) | 9.4 (239) | 11.5 (292) | 275 (125) |
| | PN25 | 26.8 (681) | - | 9.6 (243) | 12.8 (325) | 9.4 (239) | 11.5 (292) | 311 (141) |
| | PN40 | 28 (714) | - | 9.6 (243) | 12.8 (325) | 9.4 (239) | 11.5 (292) | 360 (163) |
| | PN63 | 29.7 (754) | - | 9.6 (243) | 12.8 (325) | 9.4 (239) | 11.5 (292) | 421 (191) |
| | PN100 | 32.2 (818) | - | 9.6 (243) | 12.8 (325) | 9.4 (239) | 11.5 (292) | 558 (253) |
| | JIS10K | 27.9 (709) | - | 9.6 (243) | 12.8 (325) | 9.4 (239) | 11.5 (292) | 309 (140) |
| | JIS20K | 27.9 (709) | - | 9.6 (243) | 12.8 (325) | 9.4 (239) | 11.5 (292) | 397 (180) |

Table 54: Vortex quad sensor flow meter for integral or remote transmitters, dimensions for 2 inch to 12 inch (50 mm through 300 mm) line sizes (continued)

| Nominal size, inch (mm) | Flange rating | Face-to-face Dim [Ⓐ] , inch (mm) | | Dim [Ⓟ] , inch (mm) | Dim [Ⓢ] , inch (mm) | Dim [Ⓣ] , inch (mm) | Dim [Ⓥ] , inch (mm) | Weight, lb (kg) |
|-------------------------|---------------|---|------------|------------------------------|------------------------------|------------------------------|------------------------------|-----------------|
| | | Flanged | RTJ | | | | | |
| | JIS40K | 31.4 (798) | - | 9.6 (243) | 12.8 (325) | 9.4 (239) | 11.5 (292) | 588 (267) |
| 12 inch (DN300) | 150 | 31.9 (810) | 32.3 (820) | 11.4 (289) | 13.7 (348) | 11.2 (284) | 12.4 (315) | 467 (212) |
| | 300 | 33.1 (841) | 33.6 (853) | 11.4 (289) | 13.7 (348) | 11.2 (284) | 12.4 (315) | 585 (265) |
| | 600 | 35.6 (904) | 35.7 (907) | 11.4 (289) | 13.7 (348) | 11.2 (284) | 12.4 (315) | 764 (347) |
| | PN10 | 28.2 (716) | | 11.4 (289) | 13.7 (348) | 11.2 (284) | 12.4 (315) | 377 (171) |
| | PN16 | 29.0 (737) | - | 11.4 (289) | 13.7 (348) | 11.2 (284) | 12.4 (315) | 398 (181) |
| | PN25 | 30.1 (765) | | 11.4 (289) | 13.7 (348) | 11.2 (284) | 12.4 (315) | 443 (201) |
| | PN40 | 31.9 (810) | - | 11.4 (289) | 13.7 (348) | 11.2 (284) | 12.4 (315) | 521 (236) |
| | PN63 | 33.9 (861) | - | 11.4 (289) | 13.7 (348) | 11.2 (284) | 12.4 (315) | 604 (274) |
| | PN100 | 36.3 (922) | - | 11.4 (289) | 13.7 (348) | 11.2 (284) | 12.4 (315) | 817 (371) |
| | JIS10K | 30.8 (782) | - | 11.4 (289) | 13.7 (348) | 11.2 (284) | 12.4 (315) | 467 (212) |
| | JIS20K | 30.8 (782) | - | 11.4 (289) | 13.7 (348) | 11.2 (284) | 12.4 (315) | 585 (265) |
| | JIS40K | 34.8 (884) | - | 11.4 (289) | 13.7 (348) | 11.2 (284) | 12.4 (315) | 764 (347) |

Figure 19: Vortex quad meters with CPA option

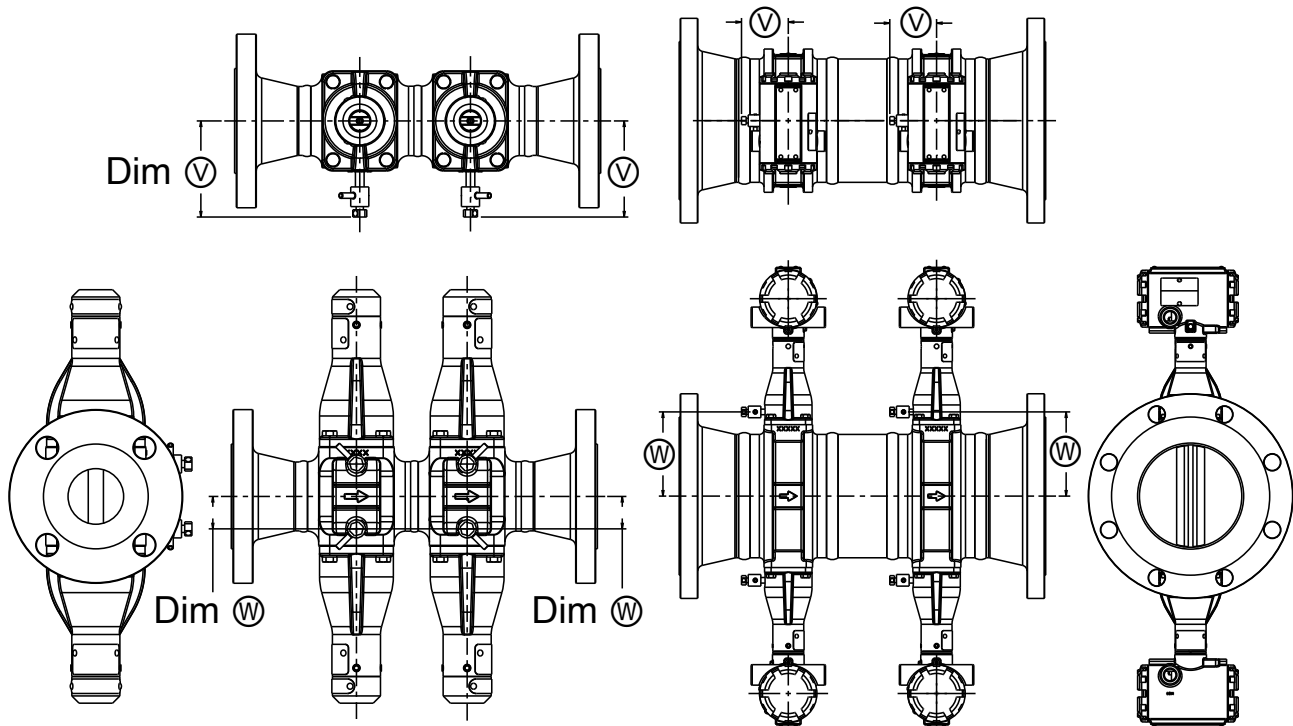

Note

For Dim ∅ and Dim ∅, see Table 55.

Table 55: Vortex integral quad meters dimensions for CPA fitting

| Nominal size, inch (mm) | Pipe center to CPA fitting, Dim ∅, inch (mm) | Pipe center to CPA fitting, Dim ∅, inch (mm) |
|-------------------------|--|--|
| 2 inch (DN50) | 3.2 (81) | 1.1 (28) |
| 3 inch (DN80) | 3.2 (81) | 1.7 (43) |
| 4 inch (DN100) | 3.2 (81) | 2.3 (58) |
| 6 inch (DN150) | 2.5 (64) | 4.5 (114) |
| 8 inch (DN200) | 2.5 (64) | 5.6 (142) |
| 10 inch (DN250) | 2.5 (64) | 6.6 (168) |
| 12 inch (DN300) | 2.5 (64) | 7.5 (191) |

Remote transmitter dimensions

Figure 20: Remote mount transmitters

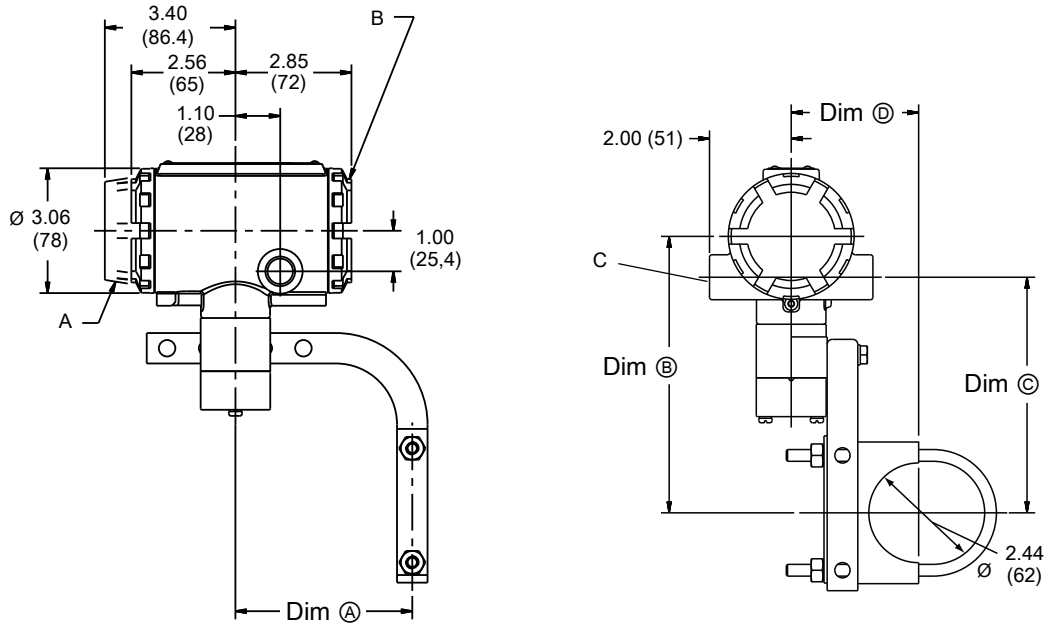

- A Display option
- B Terminal cover
- C ½-14 NPT (for remote cable conduit)

Note

Dims A, B, C, and D vary by housing material. See Table 56.

Table 56: Dimensions by transmitter housing material

| Material | Dim A inch (mm) | Dim B inch (mm) | Dim C inch (mm) | Dim D inch (mm) |
|-----------------|-----------------|-----------------|-----------------|-----------------|
| Aluminum | 4.4 (110) | 6.8 (172) | 5.8 (147) | 3.1 (79) |
| Stainless Steel | 4.5 (114) | 6.9 (175) | 5.9 (150) | 3.4 (86) |

For more information: [Emerson.com](https://www.emerson.com)

©2022 Emerson. All rights reserved.

Emerson Terms and Conditions of Sale are available upon request. The Emerson logo is a trademark and service mark of Emerson Electric Co. Rosemount is a mark of one of the Emerson family of companies. All other marks are the property of their respective owners.

ROSEMOUNT™

