

November 2017

# Types C483-24 and C484-24 Internal Valves



## WARNING

Failure to follow these instructions or to properly install and maintain this equipment could result in an explosion and/or fire causing property damage and personal injury or death.

Fisher™ equipment must be installed, operated and maintained in accordance with federal, state and local codes and Emerson Process Management Regulator Technologies, Inc. (Emerson) instructions. The installation in most states must also comply with NFPA No. 58 and ANSI Standard K61.1.

Only personnel trained in the proper procedures, codes, standards and regulations of the LP-Gas industry should install and service this equipment.

The internal valve must be closed except during product transfer. A line break downstream of a pump may not actuate the excess flow valve. If any break occurs in the system or if the excess flow valve closes, the system should be shut down immediately.

## Introduction

### Scope of the Manual

This manual covers instructions for the Types C483-24 and C484-24 3 in. CL300 RF flanged internal valves.

### Description

**Type C483-24:** The Type C483-24 double flanged internal valve is intended for special bobtail truck applications where the pump must be lowered to clear the truck frame or other obstacles. A shear section in the lower body permits the valve to shear off in the event of an accident, leaving the shutoff parts within the tank.

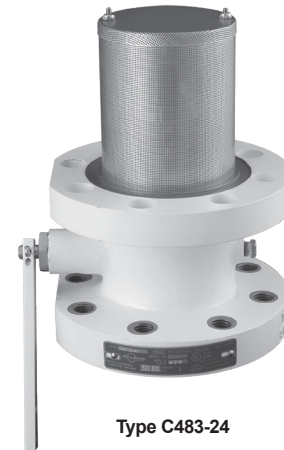

Type C483-24



Type C484-24

Figure 1. 3 In. Flanged C400 Series

**Type C484-24:** The single flanged Type C484-24 internal valve is widely used on bobtail trucks with direct connected pumps. It can also be used on in-line applications.

Both type internal valves can also be used with transports and on stationary storage tanks. The valves can be operated by cable or with air.

Designed for use with Propane, Butane or Anhydrous Ammonia at ambient temperatures, the valves can be used on other compressed gases, but the user should check with the factory to make sure the valves are suitable for the particular service.

# Types C483-24 and C484-24

## Specifications

The Specifications section shows specifications for Types C483-24 and C484-24 internal valves.

### Body Size and End Connections

**Inlet:** 3 in. CL300 RF Modified Flange  
(4 5/8 in. / 117 mm diameter bore)

**Outlet:** 3 in. CL300 RF Flange

**Maximum Allowable Inlet Pressure<sup>(1)</sup>**  
400 psig / 27.6 bar WOG

### Excess Flow Springs

**Type C483:** 160, 265 or 400 GPM /  
606, 1003 or 1514 l/min propane

**Type C484:** 160, 250 or 400 GPM /  
606, 946 or 1514 l/min propane

**Temperature Capabilities<sup>(1)(2)</sup>**  
-20 to 150°F / -29 to 66°C

### Body Material

Cast Steel WCC

### Construction Materials

**Ductile Iron:** Cage

**Steel:** Body and Operating Lever

### Construction Materials (continued)

**Stainless Steel:** Stem Assembly, Excess Flow Spring, Spring Seat, Closing Spring, Disc Holder, Disc Retainer, Screw, O-ring Seat, O-ring Retainer, Cotter Pin, Spring, Shaft, Screen, Travel Stop, Screen Cap, Bolt, Gasket and Lock Washer

**Plated Steel:** Nut, Washer, Bonnet Nut, Guide Bracket and Cap Screw

**Polyurethane (PU):** Rod Wiper

**Polytetrafluoroethylene (PTFE):**  
Bushing, Packing Adaptor and Packing Ring

**Nitrile (NBR) (Standard Construction):**  
Main Disc and Bleed Disc

### Other Disc Material Available from

**Factory:** Ethylenepropylene (EPDM), PTFE, Fluorocarbon (FKM), Neoprene (CR) and Kalrez® Perfluoroelastomer (FFKM)

### Approximate Weights

**Type C483-24:** 32 lbs / 15 kg

**Type C484-24:** 18 lbs / 8 kg

1. The pressure/temperature limits in this Instruction Manual and any applicable standard or code limitation should not be exceeded.

2. Product has passed Fisher™ testing for leakage down to -40°F / -40°C.

## DOT Internal Self-Closing Stop Valve

**Requirement—**U.S. Department of Transportation (DOT) regulations 49 CFR§178.337-8(a)(4) require each liquid or vapor discharge outlet on cargo tanks (except for cargo tanks used to transport chlorine, carbon dioxide, refrigerated liquid and certain cargo tanks certified prior to January 1, 1995) to be fitted with an internal self-closing stop valve. Fisher's "C" Series internal valves comply with the internal self-closing stop valve requirement under the DOT regulations.

## Installation

### Internal Valve

Coat both sides of the spiral wound gaskets with Dow Corning #111 silicone grease or equivalent. A 3 in. ASME CL300 RF flange with a modified bore (see Figure 2) must be installed in the tank. Special stud bolts, furnished with the valve, are assembled into this flange. The internal valve and the pump or piping flange can then be installed as shown in Figure 3.

The screen should be removed if the valve is to be used for both filling and withdrawal service or for filling alone. Filling with screen installed is not recommended.

A hydrostatic relief valve does not need to be installed adjacent to the valve since the internal valve automatically relieves excessive line pressure into the tank.

Keep piping from the valve outlet to the pump full size and as short as possible with a minimum of bends. Reduction in pipe size to suit smaller pump inlets should be made as close to the pump as possible using forged reducers (swage nipples) or venturi tapers rather than bushings. This assures minimum flow resistance and efficient pump operation.

If the valve is also used to provide excess flow protection, the flow rating of the piping, fittings, pump, valves and hose on both the inlet and outlet of the internal valve must be greater than the flow rating of the integral excess flow valve within the internal valve. If branching or other necessary restrictions are incorporated in the system which reduce the flow rating to less than that of the excess flow valve rating, the internal valve will not give excess flow protection.

## Selectively Filling Manifolded Tanks

Fisher internal valves provide positive shutoff only in one direction, from out of the tank to downstream of the valve. The internal valves are designed to allow gas

# Types C483-24 and C484-24

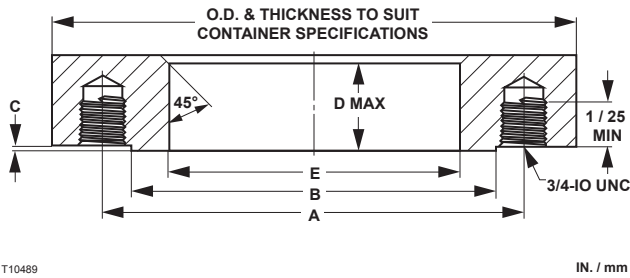

Figure 2. Tank Flange Dimensions

Table 1. Tank Flange Dimensions

FLANGE CL300 RF ASA	A-BOLTING			B RF	C RF	D	E	MATING FLANGE O.D.
	DBC	NO.	SIZE					
3	6.62 / 168	8	3/4	5.75 / 146	0.06 / 1.5	1.5 / 38	4.62 / 117	8.25 / 210

to flow into a tank when the downstream line pressure exceeds tank pressure. If you want to selectively fill one or more of the other tanks in a tank manifold system, you must place a positive shutoff valve downstream of the internal valve, otherwise, all tanks will be filled at the same time and at about the same rate.

## Actuators

The remote operating control system for the valve is extremely important and it must be installed to conform with the applicable codes. DOT MC331, for example, most generally applies for trucks.

Fisher™ offers both cable controls and pneumatic actuator systems to operate the C483 and C484 Series internal valves. It may also be possible to use cable controls from other manufacturers or to fabricate a linkage mechanism.

Any control system requires thermal protection (fuse links) at the valve, at the remote control point and, if necessary, near the hose connections. The instruction manuals for Emerson actuator systems show how to install the fuse links.

Installation instructions on Fisher Types P650, P163A and P164A cable controls, are in Form MCK-1083. Fisher Types P613 and P623 pneumatic actuators are covered in Form MCK-2159.

The operating linkage must allow the operating lever to move from the fully closed position to within 2° of the fully open position. The linkage should not apply strong force to the lever past the fully open position or the valve could be damaged.

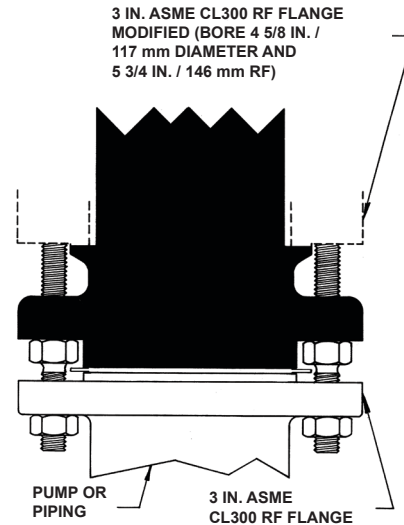

Figure 3. Type C484-24 Typical Valve Installation Schematic

## Warranty Note

The use of non-Fisher actuators will void internal valve warranty and may result in leakage of the gland packing caused by premature wear. In addition to premature wear, the use of non-Fisher actuators may result in lower than expected flow rates and possible leakage across the valve seats.

## CAUTION

The internal valve's closing spring is not designed to overcome drag in the control linkage in order to close the valve. Depending upon the control system used, an external spring (such as Fisher drawing number 1K4434) or positive closing linkage may be needed. Be sure the control system is installed to prevent binding that could cause the valve to stick in the open position.

## Excess Flow Operation

The internal valve contains an excess flow function or "integral excess flow valve," that will close when the flow exceeds the flow rating established by Fisher. Fisher's integral excess flow valve installed on a bobtail truck or transport can provide protection against the discharge of hazardous materials

# Types C483-24 and C484-24

during an unloading operation of a bobtail truck or transport in the event that a pump or piping attached directly to the internal valve is sheared off before the first valve, pump or fitting downstream of the internal valve, provided that the cargo tank pressure produces a flow rate greater than the valve's excess flow rating.

Likewise, if the internal valve is installed on a stationary tank or in the related downstream piping system, the integral excess flow valve can provide protection against an unintentional release of hazardous materials in the event that a pump or piping attached directly to the internal valve is sheared off before the first valve, pump or fitting downstream of the internal valve, provided that the flow of product through the internal valve reaches the rated flow specified by Fisher™.



## EXPLOSION HAZARD

**Restrictions incorporated in the discharge system of a bobtail truck or transport or of a stationary tank (due to pumps, pipe and hose length and dimensions, branching, elbows, reductions in pipe diameter or a number of other inline valves or fittings), low operating pressure as a result of ambient temperature or a partially closed valve downstream from the integral excess flow valve, can restrict the rate of flow through the internal valve below the level necessary to actuate the integral excess flow valve. Therefore, DO NOT USE the excess flow function of the internal valve for the purpose of providing protection against the discharge of hazardous materials in the event of a rupture of hose or piping at a point in the discharge system downstream from the first valve, pump or fitting downstream of the internal valve.**

**The internal valve is designed with an internal bleed feature for equalization of pressure. After the integral excess flow valve closes, the leakage through the bleed must be controlled or a hazard can be created. For this reason the operator must be familiar with the closure controls for the internal valves and must close the internal valve immediately after the integral excess flow valve closes.**

**Failure to follow this warning could result in serious personal injury or property damage from a fire or explosion.**

**DOT Passive Shutdown Equipment Requirement –** DOT regulations 49 CFR§173.315(n)(2) require certain cargo tanks transporting propane, anhydrous ammonia and other liquefied compressed gases to be equipped with passive emergency discharge control equipment that will automatically shut off the flow of product without human intervention within 20 seconds of an unintentional release caused by complete separation of a delivery hose. The design for each passive shutdown system must be certified by a Design Certifying Engineer (DCE) and all components of the discharge system that are integral to the design must be included in the DCE certification. The DCE certification must consider any specifications of the original component manufacturer.

In the case of downstream ruptures in hose or piping, a variety of operating conditions routinely encountered during an unloading operation restrict the rate of flow through the integral excess flow valve and make such a valve unsuitable to serve as the means of passive shutdown required under 49 CFR§173.315(n)(2). Such variables include restrictions incorporated in the discharge system (due to pumps, pipe and hose length and dimensions, branching, elbows, reductions in pipe diameter or a number of other in-line valves or fittings), low operating pressure as a result of ambient temperature or a partially closed valve downstream from the excess flow valve. Due to the variety of conditions, in the case of a hose separation, that can restrict the rate of flow below the level necessary to activate the excess flow valves, the integral excess flow function of Fisher's "C" Series internal valves or "F" Series excess flow valves cannot be used to satisfy the passive shutdown equipment requirement under/in 49 CFR§173.315(n)(2). Also, a Design Certifying Engineer cannot include the integral excess flow valve of a Fisher "C" Series internal valve or "F" Series excess flow valve as a component of the discharge system in any DCE certification under 49 CFR§173.315(n)(2).



## EXPLOSION HAZARD

**DO NOT USE the excess flow function incorporated into Fisher "C" Series internal valves or "F" Series excess flow valves to satisfy the passive**

**shutdown equipment requirement in 49 CFR§173.315(n)(2). DO NOT include the excess flow function incorporated into Fisher “C” Series internal valves or “F” Series excess flow valves in a DCE certification under 49 CFR§173.315(n)(2). The cargo tank manufacturer must install some other equipment that satisfies the requirement for passive shutdown capability under 49 CFR§173.315(n)(2).**

**Failure to follow this warning could result in serious personal injury or property damage from a fire or explosion in the event of an unintentional release of product during an unloading operation.**

## Operation

Since the Types C484-24 and C483-24 are most often used on bobtail trucks, the following procedure applies to that type of application. Follow these points:

1. Types C400s on bobtails and transports should never be open when the truck is in motion. If the control system is not interlocked to prevent this, the operator is responsible to see that the valves are closed.
2. Always open the internal valve before opening any other valves in the line or starting the pump.
3. Move the lever to the half-open position (Figure 4, View 2) to equalize pressure. When the main poppet clicks open, move the operating lever fully open.
4. Open other line valves slowly to avoid sudden surges which could slug the excess flow valve shut.
5. If the excess flow valve does close, stop the pump and close the nearest downstream valve. Move the internal valve’s operating lever back to the rapid equalizing position and wait for the valve to click open. Then move the operating lever fully open and slowly open the downstream valve.
6. All valves should be completely open when pumping. (Throttling type valves could prevent the excess flow valve from closing when required.)
7. The operator must always be aware of where the remote closure controls are located and know how to operate the controls if an emergency requires valve closure. When pumping is finished, make a

habit of closing the internal valve from the remote closure point, thus checking to see that the control actually is capable of closing the valve.

8. The valve should be open when backfilling through the valve to fill the tank.

## Troubleshooting

**Internal Valve Will Not Open** – This could be due to leakage downstream, engaging the pump too soon or from excessive wear in the internal valve. If excessive volume is in the downstream system, a longer time is required to equalize the pressures (tank and downstream) before the pump can be engaged. To determine if the valve pilot seat is opening, install a gauge downstream of the valve, operate the valve actuator; if pressure does not build up to the tank pressure, the valve pilot seat is not open. This test should be done with pump off. If the pilot is not opening, it may be plugged with dirt or some internal part may be broken. If by operating the lever manually it can be rotated past the fully open position, there is something wrong internally and the valve must be disassembled.

**Premature Valve Closure** – This can be caused from engaging the pump too soon, by an underrated excess flow valve spring or by an improperly connected internal valve operating lever which does not fully open the valve. The trouble could also be from a valve that has its inlet port obstructed or from sudden line surges. In order to check the valve opening travel, operate the lever manually to the full travel, wait until valve opens (usually about 15 seconds), then engage the pump. If the excess flow closes, the points mentioned above should be investigated.

**Internal Valve Will Not Close** – The stub shaft could be binding or the stem could be bent in the valve. Before disassembling the valve, check the actuator mechanism to see that it operates freely by disconnecting it from the valve lever and cycling it several times. Also, operate the valve lever manually. If it sticks in the open position, the packing and bushings should be replaced. This should free the operating mechanism if the valve has not been damaged internally. Refer to the “Maintenance” section.

**Low Flow Capacity** – This could be caused by too small an internal valve, too small or long downstream piping, plugged screens, some other restriction in the downstream system or by the bypass valve sticking in the open position. The bypass valve could also be set too low and be opening prematurely.

# Types C483-24 and C484-24

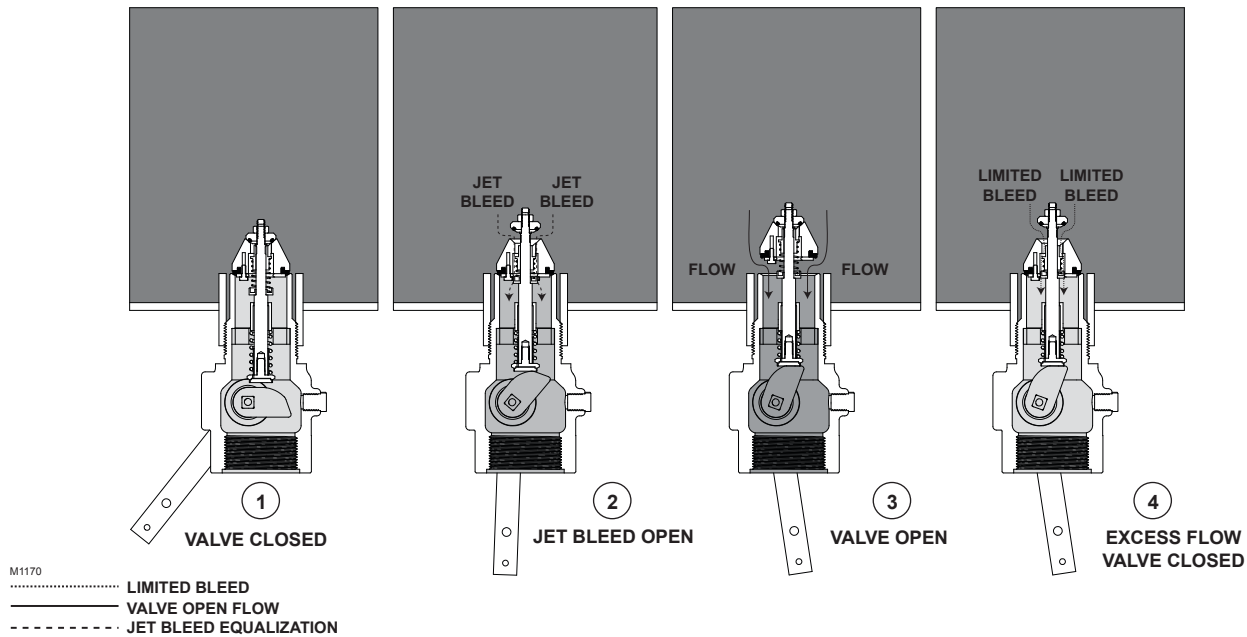

Figure 4. Operational Schematic For Types C483-24 (shown) and C484-24

## Principle of Operation (Figure 4)

The operational schematic depicts threaded valves, however flanged styles operate in the same manner.

Refer to the schematic drawing, Figure 4. In View 1, the valve is held closed by both tank pressure and the valve's closing spring. There is no leakage past the resilient seats in the poppet to the valve outlet.

The valve is opened by moving the operating lever to approximately midpoint in its 70° travel (View 2). This allows the cam to place the rapid equalization portion of the valve stem in the pilot opening, permitting a larger amount of product to bleed downstream than if the operating lever were moved to the full open position.

When tank and downstream pressure are nearly equal after a few seconds, the excess flow spring pushes open the main poppet (View 3) and the operating lever can be moved to the full open position.

If tank pressure is greater than the valve's outlet pressure, the main poppet will remain in the closed position. If valve outlet piping is closed off by other valves, however, product bleeding through the pilot will increase until it nearly equals tank pressure and the main poppet opens.

### Note

The main poppet will not open if valve outlet piping is not closed off so that the outlet pressure can approach tank pressure.

Once the main poppet opens, a flow greater than the valve's excess flow spring rating or a sufficient surge in flow forces the main poppet closed against the excess flow spring (View 4). The pilot valve allows a small amount of product to bleed, but much less than View 2 where the rapid equalization portion of the stem is placed in the pilot opening. When the operating lever is moved to the closed position, the valve closes completely and seals tightly (View 1).

## Maintenance



**Do not use these internal valves if they leak, fail to work properly or have been damaged or have missing parts. Prompt repairs should be made by a properly trained service person. Continued use without repair can create a hazardous or injurious situation.**

A simple preventative maintenance program for the valve and its controls will eliminate a lot of potential problems.

**Fisher™ recommends these steps be conducted once a month. Also refer to the Department of Transportation (DOT) CFR 49 Sections 180.416 and 180 Appendix A and B which specific monthly maintenance and inspection tests for cargo tank service internal valves and their actuation controls.**

1. Inspect the operating lever to see that it operates freely and that there is no leakage around the retainer nut. If there is sticking or leakage, replace the packing and bushings. Refer to parts list.
2. Check for tight closure of the seat discs. Any detected leakage, which is normally caused by disc wear or dirt, scale or debris embedded in the disc, requires that the internal valve be removed from service and repaired. Repair most often requires the replacement of valve discs. To check for leakage:
  - a. Close the internal valve and exhaust downstream pressure. Close the first valve downstream from the internal valve and note any pressure build-up, using a pressure gauge, between the closed valve and the internal valve. If piping is cold allow it to warm to ambient temperature.
  - b. Refer to CFR 49 Section 180 Appendix B for Meter Creep Test Methods.
3. All operating controls should be inspected, cleaned and oiled. The controls should be checked to see that they fully open—but not over-travel the internal valve operating lever and operate freely to close the valve.
4. Standard construction internal valves must be removed if the container is to be steam cleaned. Heat can damage the valve's seats and seals.
5. Standard construction internal valves are not designed for water service. Immediately after a container is hydrostatically tested, remove all water and allow the container to thoroughly dry out.
2. **For Type C484-24:** Unscrew the capscrew (key 15R) with a 7/16 in. / 11.1 mm wrench.  
**For Type C483-24:** Remove the pipe plug (key 22). Using a 3/16 in. / 4.76 mm Allen wrench, unscrew the cap screw (key 15R). Remove the washer (key 15S) and the cam (key 15P).
3. After removing the operating lever (key 18), the packing can be reached by unscrewing the bonnet nut (key 15M) and removing the stub shaft (key 15J). Inspect and replace if necessary, the packings (keys 15F, 15G and 15H), bushings (keys 15B and 15K). Lubricate the packings with Magna Lub G and the bonnet nut (key 15M) with Never Seize.
4. Reassemble in the reverse order. Replace the cap screw (key 15R) with 30 to 35 in-lbs / 3 to 4 N•m torque.
5. Make sure the operating lever (key 18) can move freely after the new parts are installed. Conduct a leak test under pressure with a leak detection solution.

## To Replace Seat Discs (keys 7 and 11) or the Excess Flow Spring (key 3):

1. Remove the valve from the tank and remove the screen from the valve.
2. Remove the Guide Bracket (key 47) for Type C483-24 or the Valve Cage (key 37) for the Type C484-24.
3. Unscrew hex nut (key 13).
4. Remove both disc holders (keys 6 and 12) from the stem (key 2).
5. Unscrew the 6 screws (key 9) holding the disc retainer (key 8) to replace the main disc seat (key 7).
6. Examine both seat discs (keys 7 and 11) and replace if necessary.
7. If the excess flow spring (key 3) is changed, restamp the nameplate with the new excess flow rating and type number.
8. Always replace the sealing washer (key 23).
9. Reassemble in the reverse order using 15 to 20 ft-lbs / 20 to 27 N•m torque to install the disc retainer (key 8). Apply Loctite 242 or equivalent on the stem threads before installing the hex nut (key 13). Tighten hex nut (key 13) to 80 in-lbs / 9 N•m torque.

## Disassembly



**Tank pressure must be released before removing the valve from the container. Failure to do so could result in personal injury.**

Numbers in parenthesis refer to key numbers in Figures 6 and 7.

## To Replace Packing (keys 15F, 15G and 15H), bushings (keys 15B and 15K) or cam (key 15P):

1. With the valve in the tank, close the operating lever (key 18, not shown) and remove the downstream pressure in the system.

# Types C483-24 and C484-24



Failure to properly center the disk retainer to the disk holder may result in improper function of the valve.

## Important

During replacement of the seat disc, use P/N GE45079T012 provided to center the disc retainer to the disc holder (see Figure 5). Keep the alignment tool inserted until all of the screws are tightened to specification. Alternately the stem assembly (key 2) and spring seat (key 4) may be used as shown in Figure 5 to perform this alignment. After assembly, check to make sure there is no interference of the spring seat and disc retainer when valve is in the excess flow position.

Pressure test the repaired valve for seat leakage, opening and closing and excess flow operation as described in earlier portions of this manual.



**Figure 5.** Use tool provided or Spring Seat (key 4) and Stem Assembly (key 2) to align Disc Retainer (key 8)

## Parts Ordering

### Important

Use only genuine Fisher™ replacement parts. Components that are not supplied by Emerson should not, under any circumstances, be used in any Fisher valve, because they will void your warranty, might adversely affect the performance of the valve and could give rise to personal injury and property damage.

When corresponding about this equipment, always reference the equipment type number found on the nameplate. When ordering replacement parts, reference the complete 11-character part number for each needed part.

## Parts List

### Type C483-24 Internal Valve (Figure 6)

Key	Description	Part Number
1	Body, Steel	T8013922012
2*	Stem Assembly	GE41522T012
2A	Stem, Stainless steel	GE35311T012
2B	Follower's Assembly, SST/PTFE	T11880000A2
2C	Groove Pin, Stainless steel	1J1560T0012
3	Excess Flow Spring, 302 Stainless steel	
	160 GPM / 606 l/min, Blue	GE42499X012
	265 GPM / 1003 l/min, Black	GE42500X012
	400 GPM / 1514 l/min, Red	GE42501X012
4	Spring Seat, Stainless steel	GE35318T012
5	Closing Spring, 302 Stainless steel	T1153737022
6	Disc Holder, Stainless steel	GE35316T012
7*	Main Disc	
	Ethylenepropylene (EPDM)	T13476T0012
	Nitrile (NBR)	T1177403032
	PTFE	T1217306242
	Fluorocarbon (FKM)	T12535T0012
	Kalrez®	T12921T0012
	Neoprene (CR)	T12914T0012
8	Disc Retainer, Stainless steel	GE35314T012
9	Screw, Stainless steel (6 required)	13B3513X022
10	Bleed disc Seat, Stainless steel	ERAA00325A0
11	Bleed disc	
	Ethylenepropylene (EPDM)	ERAA02202A0
	Nitrile (NBR)	ERAA00328A0
	PTFE	ERAA00328A1
	Fluorocarbon (FKM)	ERAA00328A2
	Kalrez®	ERAA00328A3
	Neoprene (CR)	ERAA00328A4
12	Bleed disc Retainer, Stainless steel	ERAA00324A0
13	Nut, Carbon-plated steel	T13200T0012
14	Cotter Pin,	
	Stainless steel	T1241338992
15B*	Bushing, PTFE	T1154506992

\*Recommended Spare Parts  
Kalrez® is a mark owned by E.I. du Pont de Nemours and Co.



# Types C483-24 and C484-24

## Type C483-24 Internal Valve (Figure 6) (continued)

Key	Description	Part Number	Key	Description	Part Number
15C*	Washer, Zinc-plated steel	T1154625072	7*	Main Disc	
15D	Spring, 302 Stainless steel	T1154737022		Ethylenepropylene (EPDM)	T13476T0012
15E*	Washer, Zinc-plated steel (2 required)	T1154825072		Nitrile (NBR)	T1177403032
15F*	Male Packing Adaptor, PTFE	T1154901012		PTFE	T1217306242
15G*	Packing Ring, PTFE (3 required)	T1155001012		Fluorocarbon (FKM)	T12535T0012
15H*	Female Packing Adaptor, PTFE	1H941601012		Kalrez®	T12921T0012
15J	Shaft, 303 Stainless steel	T2043135072		Neoprene (CR)	T12914T0012
15K*	Bushing, PTFE	T1155106992	8	Disc Retainer, Stainless steel	GE35314T012
15L*	Rod Wiper, Polyurethane (PU)	T1155206992	9	Screw, Stainless steel (6 required)	13B3513X022
15M	Bonnet Nut, Zinc-plated steel	T1155324102	10	Bleed disc Seat, Stainless steel	ERAA00325A0
15P	Cam	T1155521992	11*	Bleed disc	
15R	Cap Screw	T12576T0012		Ethylenepropylene (EPDM)	ERAA02202A0
15S	Washer, Carbon-plated steel	1C225628982		Nitrile (NBR)	ERAA00328A0
18	Operating Lever			PTFE	ERAA00328A1
	Standard	T1155919312		Fluorocarbon (FKM)	ERAA00328A2
	Stainless steel	T11559T0022		Kalrez®	ERAA00328A3
19*	Cotter Pin			Neoprene (CR)	ERAA00328A4
	Standard	1H837128982	12	Bleed disc Retainer, Stainless steel	ERAA00324A0
	Stainless steel	1H8371T0022	13	Nut, 303 Stainless steel	T12765T0012
21	Drive Screw (2 required) (not shown)		14	Cotter Pin	
	Stainless steel	ERAA05928A0		Stainless steel	T1241338992
22	Pipe Plug, Zinc	T13718T0012	15B	Bushing, PTFE	GE39719T012
23*	Washer, Zinc	T1188228982	15C*	Washer, Zinc-plated steel	T1154625072
25	Screen, Stainless steel	T12317T0012	15D	Spring, 302 Stainless steel	T1154737022
30	Fusible Link (not shown)	1J157443992	15E	Washer, Zinc-plated steel (2 required)	T1154825072
33	Travel Stop		15F*	Male Packing Adaptor, PTFE	T1154901012
	Stainless steel	T1240838072	15G*	Packing Ring, PTFE (3 required)	T1155001012
38	Screen Cap, Stainless steel	T12318T0012	15H	Female Packing Adaptor, PTFE	1H941601012
39	Nut, Carbon-plated steel (2 required)	1J719228982	15J	Shaft, 303 Stainless steel	T2043135072
40	Bolt, 410/416 Stainless steel (2 required)	T1127235132	15K*	Bushing, PTFE	T1155106992
41	Stud Bolt (16 required), Stainless steel	1N946228982	15L*	Rod Wiper, Polyurethane (PU)	T1155206992
42	Nut, Stainless steel (16 required)	1A368124112	15M	Bonnet Nut, Zinc-plated steel	T1155324102
43*	Upper Gasket, 304 Stainless steel (not shown)	T13603T0012	15P	Cam	T1155521992
44*	Lower Gasket, 304 Stainless steel (not shown)	T1056138992	15R	Cap Screw, Zinc-plated steel	1B848024052
47	Guide Bracket, Zinc-plated steel	T20798T0012	15S	Washer, Carbon-plated steel	1C225628982
53	Cap Screw, Carbon-plated steel (2 required)	T12776T0012	18	Operating Lever	
55	Lock Washer, Stainless steel (3 required)	1C2257K0012		Standard	T1155919312
				Stainless steel	T11559T0022
			19	Cotter Pin	
				Standard	1H837128982
				Stainless steel	1H8371T0022
			21	Drive Screw (2 required)	
				Stainless steel	ERAA05928A0
			23*	Washer, Zinc	T1188228982
			25	Screen, Stainless steel	T12317T0012
			29	Cap Screw, Carbon-plated steel (4 required)	T12775T0012
			30	Fusible Link (not shown)	1J157443992
			33	Travel Stop	
				Stainless steel	T1240838072
			35*	Bushing, PTFE	GE39719T012
			37	Cage, Ductile iron	GE38521T012
			38	Screen Cap, Stainless steel	T13473T0012
			40	Bolt, Carbon-plated steel	T12776T0012
			41	Stud Bolt, Zinc-plated steel (8 required)	1P790832982
			42	Nut, Stainless steel (16 required)	1A368124112
			43	Upper Gasket, 304 Stainless steel (not shown)	T13603T0012
			44	Lower Gasket, 304 Stainless steel (not shown)	1P877699152
			55	Lock Washer, Stainless steel	1C2257K0012

## Type C484-24 Internal Valve (Figure 7)

Key	Description	Part Number	Key	Description	Part Number
1	Body, Steel	GE38652T012			
2*	Stem Assembly	GE41522T012			
2A	Stem	GE35312T012			
2B	Follower Assembly	T11880000A2			
2C	Groove Pin	1J1560T0012			
3	Excess Flow Spring, 302 Stainless steel				
	160 GPM / 606 l/min, Blue	GE42499X012			
	250 GPM / 946 l/min, Orange	T1192437022			
	400 GPM / 1514 l/min, Yellow	GE42851X012			
4	Spring Seat, Stainless steel	GE35319T012			
5	Closing Spring, 302 Stainless steel	T1153737022			
6	Disc Holder, Stainless steel	GE35316T012			

\*Recommended Spare Parts  
Kalrez® is a mark owned by E.I. du Pont de Nemours and Co.

# Types C483-24 and C484-24

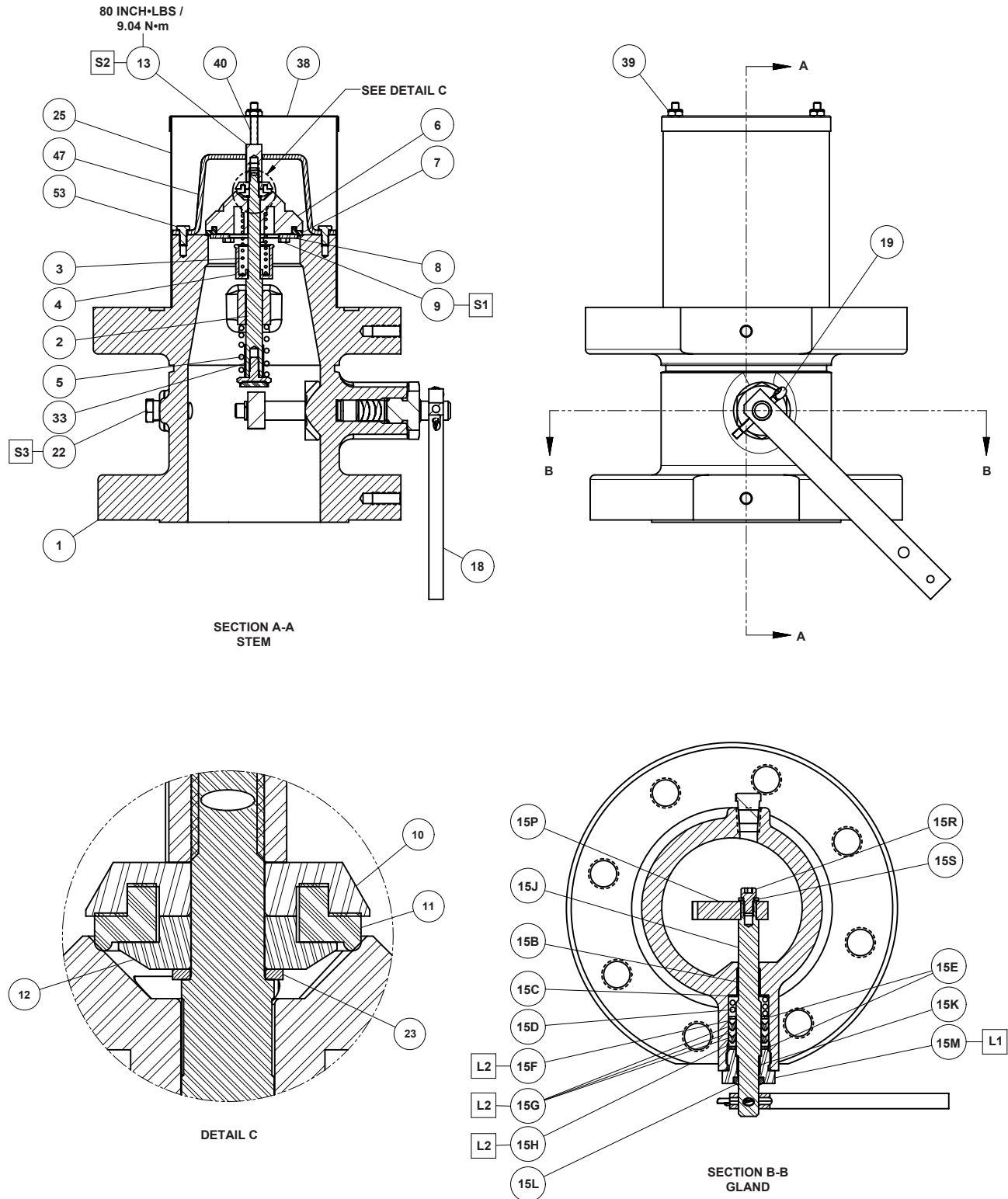

GE41635

- APPLY LUB/SEAL/ADH
- S1 = MEDIUM STRENGTH THREADLOCKER
- S2 = HIGH STRENGTH THREADLOCKER
- S3 = PIPE THREAD TAPE
- L1 = ANTI-SEIZE COMPOUND
- L2 = MULTI-PURPOSE PTFE LUBRICANT

Figure 6. Type C483-24 Internal Valve Assemblies

# Types C483-24 and C484-24

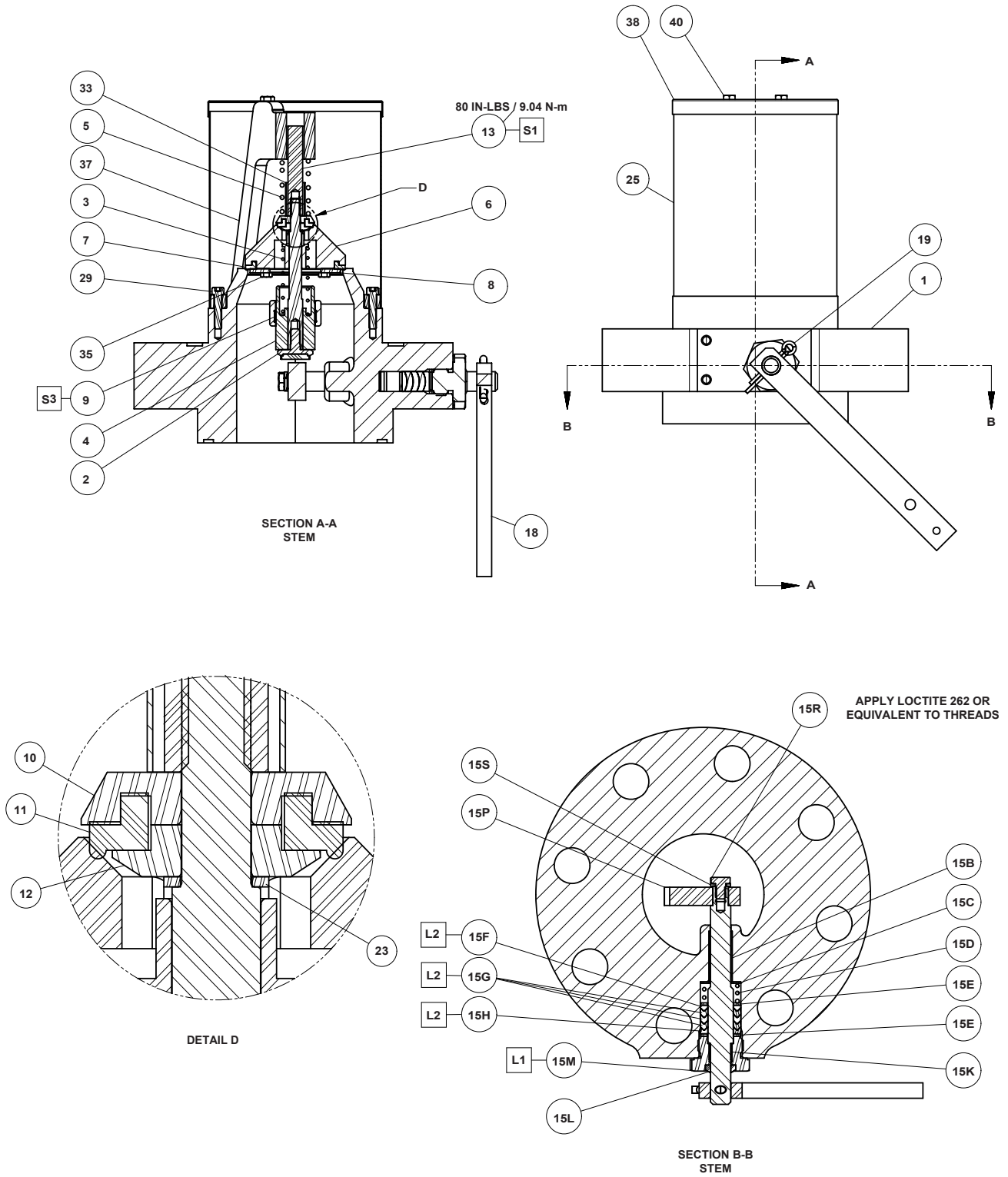

GE41562

- APPLY LUB/SEAL/ADH
- S1 = MEDIUM STRENGTH THREADLOCKER
- S2 = HIGH STRENGTH THREADLOCKER
- S3 = PIPE THREAD TAPE
- L1 = ANTI-SEIZE COMPOUND
- L2 = MULTI-PURPOSE PTFE LUBRICANT

Figure 7. Type C484-24 Internal Valve Assemblies

# Types C483-24 and C484-24

---

✉ [Webadmin.Regulators@emerson.com](mailto:Webadmin.Regulators@emerson.com)

🔍 [Fisher.com](http://Fisher.com)

📘 [Facebook.com/EmersonAutomationSolutions](https://Facebook.com/EmersonAutomationSolutions)

🌐 [LinkedIn.com/company/emerson-automation-solutions](https://LinkedIn.com/company/emerson-automation-solutions)

🐦 [Twitter.com/emr\\_automation](https://Twitter.com/emr_automation)

## Emerson Automation Solutions

### Americas

McKinney, Texas 75070 USA  
T +1 800 558 5853  
+1 972 548 3574

### Europe

Bologna 40013, Italy  
T +39 051 419 0611

### Asia Pacific

Singapore 128461, Singapore  
T +65 6770 8337

### Middle East and Africa

Dubai, United Arab Emirates  
T +971 4 811 8100

D450230T012 © 2009, 2017 Emerson Process Management Regulator Technologies, Inc. All rights reserved. 11/17.

The Emerson logo is a trademark and service mark of Emerson Electric Co. All other marks are the property of their prospective owners. Fisher™ is a mark owned by Fisher Controls International LLC, a business of Emerson Automation Solutions.

The contents of this publication are presented for information purposes only, and while effort has been made to ensure their accuracy, they are not to be construed as warranties or guarantees, express or implied, regarding the products or services described herein or their use or applicability. All sales are governed by our terms and conditions, which are available on request. We reserve the right to modify or improve the designs or specifications of our products at any time without notice.

Emerson Process Management Regulator Technologies, Inc. does not assume responsibility for the selection, use or maintenance of any product. Responsibility for proper selection, use and maintenance of any Emerson Process Management Regulator Technologies, Inc. product remains solely with the purchaser.

