



YARWAY HANCOCK GLOBE STYLE LIFT CHECK VALVE

SERIES 5540

Spring loaded, globe style lift check valve ASME Class 800 may be installed in horizontal and vertical piping applications.



FEATURES

- Disc is spring loaded for positive closure in any position.
- The disc is hardened, ground and lapped, to ensure leak free sealing over the valve's full pressure temperature range.
- Seat is overlaid with Stellite or equal hardfacing.
- The integral seat hardfacing is overlaid directly onto the body base material, eliminating any possibility of leakage behind the seat.
- Flat, precision machined and lapped seating surfaces eliminate damage from high impact seating.
- All internal surfaces are accurately machined to provide maximum performance.
- Socket weld ends standard.
- Standard body and bonnet materials are carbon steel (ASME SA105).
- Code compliance with ASME 16.34 and the ASME boiler and pressure vessel code, Section I.

GENERAL APPLICATION

5540 series lift check valves are designed for ASME boiler and pressure vessel code, Section I locations and are recommended for applications where leak-tight prevention of flow reversal is required. The 5540 is especially efficient in high temperature/high pressure steam, water and chemical applications.

TECHNICAL DATA

Size range: NPS ½ to 2
Class 800 LTD class

YARWAY HANCOCK GLOBE STYLE LIFT CHECK VALVE

SERIES 5540

High strength bolting – extra heavy hex head cap screws use standard tools for easy maintenance.

Body cap joint – metal to metal surface contact for automatic gasket compression and elimination of flange overstressing.

Forged body and cap – in full accordance with ASME boiler and pressure vessel code, Section I design and material requirements.

Hardened disc – precision guided on cap centerpost. Flat seat design ensures positive alignment of seating surfaces, regardless of valve's installed position, and absorbs sudden closure impact.

Hard faced seat – all hardfacing is overlaid to extra depth, to ensure maximum reparability.

End connections – in accordance with ASME B16.34 and are available socket weld.

Full code compliance – complies with ASME B16.34 and Section I of the ASME boiler and pressure vessel code, section I.

Top entry design – allows for complete valve maintenance without removal from the line.

Graphite filled gasket – spiral wound, stainless steel, graphite filled, with controlled compression for zero leakage at maximum design pressure and temperature.

Inconel® spring – allows for positive closure at full valve temperature rating

Center guided disc – keeps disc from cocking and/or binding. Prevents galling of stem and disc surfaces.

Install in any position – spring loaded for positive closure in any installed position.

Built in relief port – allows rapid evacuation of line fluid from disc cavity.

Large ports and seats – for high flow and low pressure drop. High disc lift allows maximum flow at minimum pressure differential.

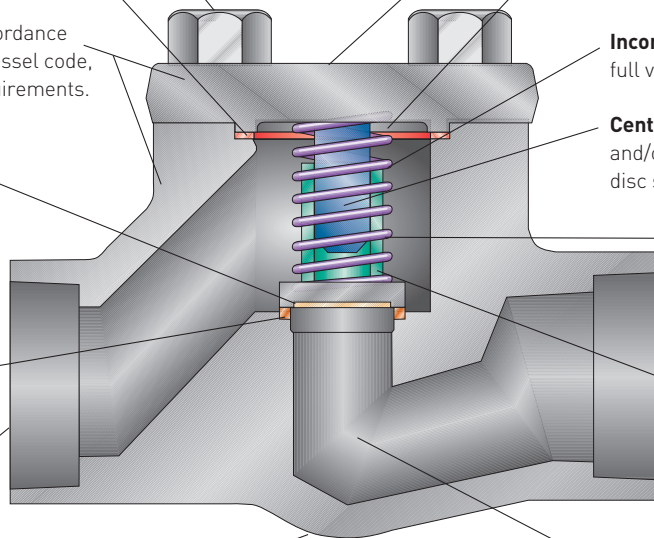

GLOBE STYLE LIFT CHECK VALVES

Check valves, or "non-return" valves as they are often called, are made in a variety of designs, including globe lift, piston, ball, swing, tilting disc, squib, flapper, etc. All serve the same function, which is to allow flow in one direction, while preventing flow in the other. The most common types of globe lift check valves are T-Pattern and Y-Pattern. The standard globe type lift check valve consists of a disc (inner valve), encapsulated within a capped body. The disc is spring-loaded, fully guided by the body bore and rests on the valve seat, integral with the body. The valve is installed with the flow under the disc, such that the inlet line pressure will force the disc to "lift" off the seat and allow the line fluid to flow through the valve. Should the flow suddenly reverse itself, the disc will automatically and quickly, assisted by the weight of the disc and spring, be forced to the closed position, preventing the line fluid from returning.

Some lift check valves have no spring and depend on the weight of the disc to start closure. These are called "horizontal lift check valves," as they will only function properly when installed in a horizontal line. Spring loaded lift check valves may be installed in any position, both in horizontal and vertical piping applications. The spring also helps reduce noise, and minimize the effect of pulsating flow and "water hammer" line shock. Y-Pattern globe style lift check valves, with their smoother, less torturous flow passages, usually have a significantly higher flow capacity than T-Pattern designs.

YARWAY HANCOCK GLOBE STYLE LIFT CHECK VALVE

SERIES 5540

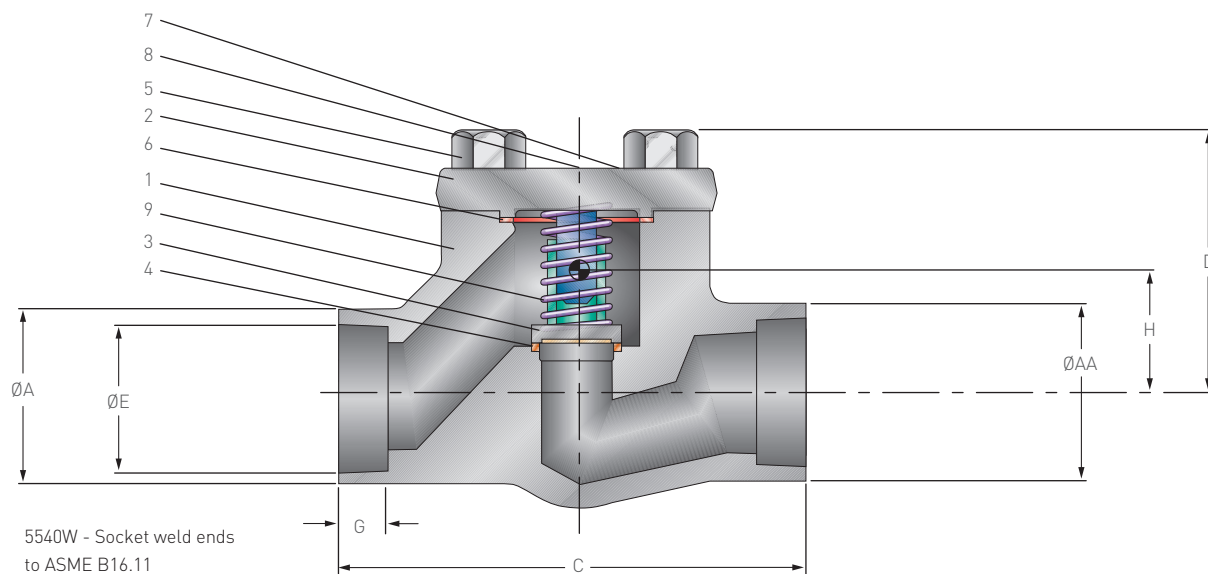

PARTS LIST

No.	Description	Material
1	Body	ASME SA105 Carbon steel
2	Cap	ASME SA105 Carbon steel
3	Valve	420 Stainless steel
4	Seat facing	Stellite or equivalent
5	Cap bolt	B7 Alloy steel (phosphated)
6	Cap gasket	304 S/S (Graphite) filled
7	Marker plate	304 Stainless steel
8	Metal tack	304 Stainless steel
9	Spring	Inconel® X750

DIMENSIONS (inches)

Valve size NPS	ØA	ØAA	C	D	ØE	G	H	Wt.	Cv
1/2	1 5/16	1 5/16	3 9/16	1 15/16	0.855	3/8	1 3/16	3.75	1.8
3/4	1 1/2	1 1/2	3 9/16	2 3/16	1.065	1/2	1 5/16	4.00	3.5
1	1 7/8	1 7/8	4 3/8	2 23/32	1.330	1/2	1 1/8	6.25	6.0
1 1/2	2 1/2	2 1/2	6 1/2	4 3/16	1.915	1/2	1 5/8	13.50	21.0
2	3 1/8	3 1/8	7	5	2.406	5/8	2	22.25	23.0

BODY, BONNET AND TRIM MATERIAL COMBINATIONS

Variation	Standard / 13% Cr. Trim
Suffix No.	None
Valve types available	5540S-W
Body	Carbon steel SA105
Bonnet	Carbon steel SA105
Seat	Hard faced with Stellite or equal
Valve disc	420 S/S
Spring	Inconel®
Gasket	304 S/S Spiral wound Grafoil® filled

YARWAY HANCOCK GLOBE STYLE LIFT CHECK VALVE

SERIES 5540

TYPICAL SPECIFYING SEQUENCE

Example	NPS 1/2	5540	W	2	-
Nominal valve size NPS					
1/2, 3/4, 1, 1 1/2, 2					
Valve type number					
5540 – Globe style lift check valve, Integral seat					
End connection					
W - Socket end					
Design change number					
2					
Material combination suffix					
None – A105 Body and Bonnet, 13 Cr. Trim					