

STF Series – Active Tracking® Filters

Low voltage/high frequency noise is caused by everyday events such as turning on machinery, motors, or equipment. Although noise is less dramatic than high voltage transients, the long term effects of these frequent disturbances can be as damaging. Filtering systems such as SolaHD Active Tracking® Filters provide clean AC power by eliminating lower voltage noise.

The SolaHD STF Series offers our original active tracking technology to guard against commonly occurring but very damaging, lower energy transients. Offering excellent noise reduction, the filter continuously tracks the input AC power line and responds instantly upon detecting extraneous high frequency noise.

The STF Series eliminates low voltage/high frequency noise via a low-pass or L-C filter. These filters are used for low energy, high frequency noise reduction and consist of a series of inductors, capacitors and resistors. STF's are load dependent which means that the series inductors located on each phase and neutral conductors are sized to handle the maximum current draw on the line. These inductors together with the capacitors and resistors form a circuit capable of absorbing a large bandwidth of noise.

These devices are designed to meet UL 1283, and CSA C22.2 No. 8 for Electromagnetic Interference Filters. STF's attenuate or reduce the amplitude of noise to a minimum of 40 dB that occurs in a frequency range of 50 kHz to 50 MHz. They also provide the industry's best IEEE Category "A" protection, typically reducing normal mode transients to +/- 5 volts.

Built to meet your unique requirements, these filters are available in a multitude of voltage configurations. They are hardwired and designed for years of trouble free operation requiring little or no operator intervention after installation.

Active Tracking® Filters are one part Emerson's a total power quality solution. They can be used alone or in conjunction with other SolaHD products to solve more complex power quality problems.

Applications

- Branch and Control Panels
- Factory Automation Installations
- Point of Use Industrial Service Equipment
- Dedicated Industrial and Machine Tools Equipment
- Telecommunications Equipment



Features

- Non degrading, series filter technology for total durability
- High frequency noise filter, RLC low-pass filter
- Three phase applications up to 200 amp
- Attenuates noise to 40 dB in frequency range of 50 kHz to 50 MHz
- Operating temperature from -40°C to +45°C
- Hardwired connection
- MTBF greater than 100,000 hours, Mil Std. 217F
- Ten year limited warranty

Certifications and Compliances

-  Listed
 - UL 1283
 - CSA C22.2 No. 8
- RoHS Compliant

Related Products

- Power Conditioners
- Uninterruptible Power System
- Power Supplies

Selection Table

Catalog Number	Amps	Min. Wire Size (AWG Suggested)	Fuse/Circuit Breaker Ampacity		Case Dim. in (mm) – A x B x C	Mounting Flange Dim. in (mm) – D x E x F	Weight lbs (kg)	Design Style
			Suggest	Max				
Three phase Models (120/208 Vac wye) *								
STF0150-10Y	15.0	14	15A	18.75A	14.00 x 12.00 x 6.00 (355.6 x 304.8 x 152.4)	14.75 x 10.0 x 15.5 (374.7 x 254.0 x 393.7)	35.0 (19.90)	4
STF0300-10Y	30.0	10	30 A	37.5A	14.00 x 12.00 x 6.00 (355.6 x 304.8 x 152.4)	14.75 x 10.0 x 15.5 (374.7 x 254.0 x 393.7)	35.0 (19.90)	4
STF0500-10Y	50.0	4	50A	62.5A	16.00 x 14.00 x 8.00 (406.4 x 355.6 x 203.2)	16.75 x 12.00 x 18.5 (425.4 x 304.8 x 469.9)	45.0 (20.41)	2
STF1000-10Y	100.0	2	100A	125 A	20.00 x 16.00 x 10.00 (508 x 406.4 x 254)	21.25 x 10.0 x 22.5 (539.8 x 254.0 x 571.5)	65.0 (29.48)	2
STF2000-10Y	200.0	3/0	200A	250A	24.00 x 20.00 x 10.00 (609.6 x 508 x 254)	25.25 x 14.0 x 26.5 (641.4 x 355.6 x 673.1)	115.0 (52.16)	2
Three phase Models (240 V Delta) *								
STF0150-24D	15.0	14	15A	18.75A	14.00 x 12.00 x 6.00 (355.6 x 304.8 x 152.4)	14.75 x 10.0 x 15.5 (374.7 x 254.0 x 393.7)	35.0 (19.90)	4
STF0300-24D	30.0	10	30 A	37.5A	14.00 x 12.00 x 6.00 (355.6 x 304.8 x 152.4)	14.75 x 10.0 x 15.5 (374.7 x 254.0 x 393.7)	35.0 (19.90)	4
STF0500-24D	50.0	4	50A	62.5A	16.00 x 14.00 x 8.00 (406.4 x 355.6 x 203.2)	16.75 x 12.00 x 18.5 (425.4 x 304.8 x 469.9)	45.0 (20.41)	2
STF1000-24D	100.0	2	100A	125 A	20.00 x 16.00 x 10.00 (508 x 406.4 x 254)	21.25 x 10.0 x 22.5 (539.8 x 254.0 x 571.5)	65.0 (29.48)	2
STF2000-24D	200.0	3/0	200A	250A	24.00 x 20.00 x 10.00 (609.6 x 508 x 254)	25.25 x 14.0 x 26.5 (641.4 x 355.6 x 673.1)	115.0 (52.16)	2
Three phase Models (277/480 V wye) *								
STF0150-27Y	15.0	14	15A	18.75A	14.00 x 12.00 x 6.00 (355.6 x 304.8 x 152.4)	14.75 x 10.0 x 15.5 (374.7 x 254.0 x 393.7)	35.0 (19.90)	4
STF0300-27Y	30.0	10	30 A	37.5A	14.00 x 12.00 x 6.00 (355.6 x 304.8 x 152.4)	14.75 x 10.0 x 15.5 (374.7 x 254.0 x 393.7)	35.0 (19.90)	4
STF0500-27Y	50.0	4	50A	62.5A	16.00 x 14.00 x 8.00 (406.4 x 355.6 x 203.2)	16.75 x 12.00 x 18.5 (425.4 x 304.8 x 469.9)	45.0 (20.41)	2
STF1000-27Y	100.0	2	100A	125 A	20.00 x 16.00 x 10.00 (508 x 406.4 x 254)	21.25 x 10.0 x 22.5 (539.8 x 254.0 x 571.5)	65.0 (29.48)	2
STF2000-27Y	200.0	3/0	200A	250A	24.00 x 20.00 x 10.00 (609.6 x 508 x 254)	25.25 x 14.0 x 26.5 (641.4 x 355.6 x 673.1)	115.0 (52.16)	2
Three phase Models (480 V Delta) *								
STF0150-48D	15.0	14	15A	18.75A	14.00 x 12.00 x 6.00 (355.6 x 304.8 x 152.4)	14.75 x 10.0 x 15.5 (374.6 x 254.0 x 393.7)	35.0 (19.90)	4
STF0300-48D	30.0	10	30 A	37.5A	20.0 x 16.0 x 10.0 (508.0 x 406.4 x 254.0)	21.25 x 10.0 x 21.5 (539.75 x 254.0 x 546.1)	35.0 (19.90)	4
STF0500-48D	50.0	4	50A	62.5A	20.0 x 16.0 x 10.0 (508.0 x 406.4 x 254.0)	21.25 x 10.0 x 21.5 (539.75 x 254.0 x 546.1)	45.0 (20.41)	4
STF1000-48D	100.0	2	100A	125 A	20.00 x 16.00 x 10.00 (508 x 406.4 x 254)	21.25 x 10.0 x 21.5 (539.8 x 254.0 x 546.1)	65.0 (29.48)	2
STF2000-48D	200.0	3/0	200A	250A	24.00 x 20.00 x 10.00 (609.6 x 508 x 254)	25.25 x 14.0 x 25.5 (641.4 x 355.6 x 647.7)	115.0 (52.16)	2

* Units are standard in NEMA 12 hinged enclosures.

STF Specifications

Description	120/208 Vac Models	277/480 Vac Models	480 Vac Models
Input Voltage	0-150/240 Vrms	0-320/520 Vrms	0-520 Vrms
Line Frequency	50/60 Hz		
Transient Attenuation Response Time	Instantaneous		
Mean Time Between Failure (MTBF)	> 100,000 Hours (Mil Std. 217F)		
Packaging	Single phase < 30 amps housed in black, high impact plastic case, vacuum impregnated magnetics, epoxy encapsulated. Single phase > 30 amps, 480 Vac, and three phase units housed in NEMA 12 enclosures.		
Operating Temperature	-40°C to +45°C; Derate Linearly to 60% at +70°C		
Load Surge Current Rating	10m sec: 5 x Nominal		
	1 sec : 3 x Nominal		
	5 sec: 2 x Nominal		
Transient Reduction	Minimum of 40 dB from 50 kHz through 50 MHz. Attenuation is greater than 50 dB to the surge withstand capability Ringwave test IEEE C62.41, Category "A" (IEEE Category A Ringwave 6 kV, 200A, 100 kHz) and "B" (IEEE Category B Ringwave 6 kV, 500 A, 100 kHz).		
Warranty	10 year limited warranty		

Dimensional Drawings See Selection Table for dimensions (in. and mm.)

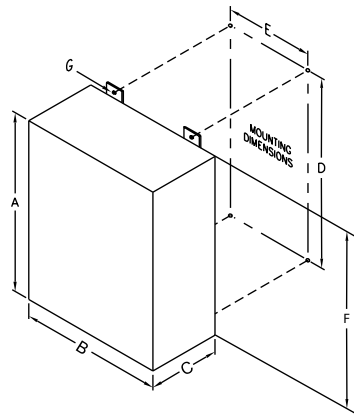

Design Style 2

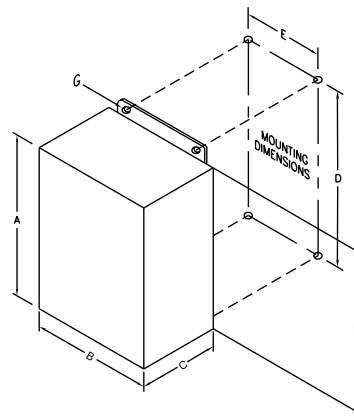

Design Style 4