

Rosemount™ Tank Gauging System



Always ready for your next challenge
Solutions for bulk liquid storage



Insights delivered. Right away.



Table of contents

System Features	4-7
Radar Level Measurements	8-10
Temperature Measurements	11
Inventory Management Software and Functions	12-13
Safety: Overfill Prevention, Proof-testing, Floating Roof Monitoring	14-18
Upgrade/Expansion Projects: Emulation and Wireless Communication	19-23
Complete Solutions for Storage of Liquefied Gas in Full Containment Tanks	24-25
Solutions from the Inventor of Radar Tank Gauging	26-27

Efficiency



Access to precise data in real time speeds up plant operations

Safety



Overfill prevention solutions fulfilling API 2350 and IEC 61511

Accuracy



Reliable net volume calculations based on API and ISO standards

Scalability



Open communication standard simplifies adding devices

Emerson helps you meet every challenge today and tomorrow

Manufacturers experience increasing demands for productivity and resource optimization on a scale never seen before in order to drive business performance.

With the Rosemount Tank Gauging System you are always ready to handle the critical demands on efficiency, safety, accuracy, reliability and data security. You will be able to get precise net volume inventory calculations complying with the latest overfill prevention standards, now and in the future. Independent of your tank gauging inventory measurement challenge, we have the solutions helping your business to achieve top quartile performance:

- Secure efficient operations
- Raise the level of safety
- Ensure precise measurements

Take control of your tank farm



Accuracy, reliability, and safety in tank gauging

A tank gauging system should be able to provide high accuracy net volume and mass inventory calculations according to the rules set forth by industry standard organizations such as API. The OIML standard R 85:2008 defines the highest accuracy requirements for tank gauges used in custody transfer applications. High inventory measurement accuracy is also needed for loss control and mass balance purposes. In addition, tank gauging devices provide the basic process control layer in the tank farm. Independent high level indicators or level-switches form the next layer of protection. Any undetected failure of these two protection layers can cause disastrous accidents. Be confident that Emerson provides scalable tank gauging system solutions to meet these needs.



Control your inventory and know the exact amount of products in the tanks. Inventory control is a crucial management tool, involving large assets.

Measure precise batches and custody transfers between ship and shore as well as for pipeline transmission systems.

Perform oil movement and operations functions for everyday operations, scheduling purposes and blending programs.

Keep track of leaks and prevent overfills to reduce environmental impact and the financial consequences of oil losses.



Boost efficiency

A Rosemount Tank Gauging System helps you increase plant performance and reduce downtime:

- Get reliable and accurate tank information in real time
- Utilize tank capacity efficiently, and fill tanks higher
- Install new devices and replace existing equipment easily



Improve safety

With no moving parts and non-contact measurement, radar technology is fundamentally reliable:

- Benefit from unique 2-in-1 solution for safety upgrades of existing tanks with a minimum of modification
- Get API 2350 and IEC 61511 compliant solutions for automatic and manual overfill prevention systems
- Make remote proof-testing without affecting the process
- Benefit from continuous monitoring of the floating roof position



Increase accuracy

For decades, Rosemount radar level gauges have been the obvious choice when precision is critical:

- Measure levels with an instrument accuracy of ± 0.5 mm (0.02 in.)
- Calculate precise net volumes by combining accurate level and average temperature measurement
- Use for all tank storage purposes—from tank monitoring or operational control to custody transfer applications with full inventory management

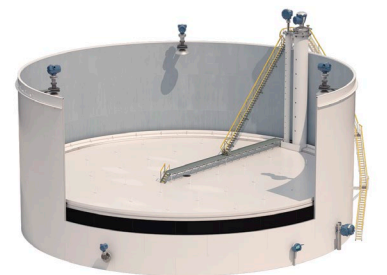

Go wireless

There are many situations when wireless is the logical choice to:

- Connect with tanks that are divided by water, roads or other obstacles
- Avoid excavation work—reduce risk, shorten installation time, and save cost
- Create a redundant communication path quickly and easily— simply add a wireless network to your existing wired installation



Whatever your next step, you will be ready

Connect new equipment to your tank farm easily as the Rosemount Tank Gauging System is open and scalable. You are always ready to expand your plant and replace damaged or outdated technology—with rugged and reliable equipment designed for all climates.

- Maintain high plant efficiency
- Comply with new regulations
- Protect the value of your assets

Simplify tank farm automation

Use wireless communication to automate your bulk liquid tank content measurements. This solution is based on IEC 62591 (WirelessHART®).

Combine devices freely

Our Tankbus uses the open communication standard FOUNDATION™ Fieldbus, allowing you to connect the gauging units you need on the tank. The Tankbus is two-wired, self-configuring and intrinsically safe allowing cabling without conduits. Communication from the tank hub to the control room can be made via our Modbus based fieldbus, other major fieldbus standards or wireless transmission.

Migrate legacy systems seamlessly

Replace outdated level gauges with high-performing gauges from Emerson thanks to advanced emulation technology.

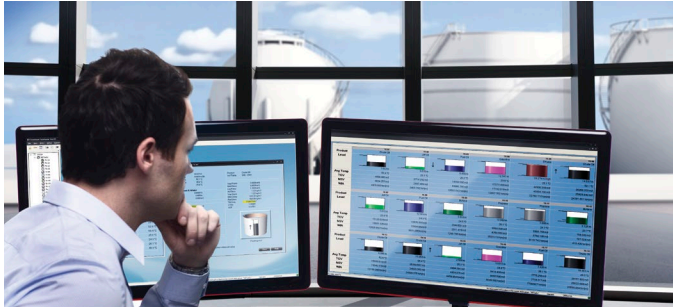

Stay in charge of operations

Control your plant with Rosemount TankMaster—get real-time gross and net volume calculations based on the latest API and ISO standards as well as alarm, inventory and custody transfer functions. The user-friendly interface increases productivity and ease of plant management.

Measure density and mass

Create a hybrid inventory measurement system by connecting a pressure transmitter for real-time density and mass calculations in addition to net volume. Get all tank parameters from one system and reduce the need for manual sampling.

System overview

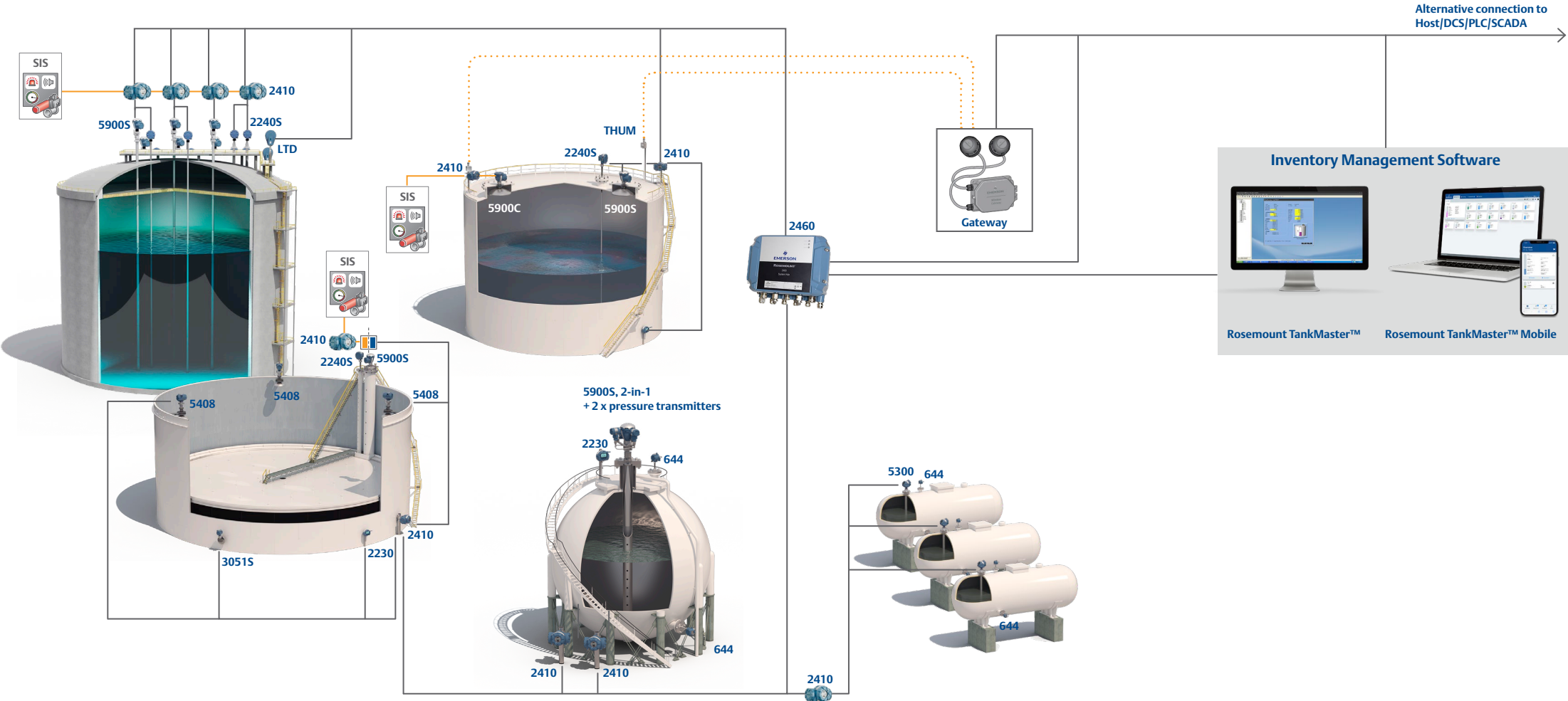

When every drop counts, you can count on radar technology



Rosemount 5900S Radar Level Gauge
±0.5 mm (0.02 in.)

Improve inventory measurements

Get more precise tank gauging with Emerson's Rosemount Tank Gauging System and benefit from better tank utilization, less inventory uncertainty and more accurate billing. No moving parts make the radar level gauges reliable, virtually maintenance-free and long lasting. The money you invest in the system is soon paid back and turned into years of profit.

- Improve net volume calculations
- Enhance inventory volume control
- Use for all tank storage applications

Strengthen accuracy with radar level gauges

Choose non-contacting gauges with an instrument level measurement accuracy of ±0.5 mm (0.02 in.) and get precise data for custody transfer, inventory management and loss control.

Rosemount Tank Gauging System is accuracy certified for custody transfer by the International Organization of Legal Metrology (OIML) and many international institutes such as CMI, GOST, LNE, NMI and PTB.

Combine level measurements with precise multiple spot temperature for exact net volume calculations.



Rosemount 5900C Radar Level Gauge
±2.0 mm (0.079 in.)



Unfold and inspect
Both Rosemount 5900S and 5900C are available in an openable version enabling sampling and verification hand-dips in one single pipe

Solve contamination challenges

Install Rosemount radar level gauges with parabolic antennas and get reliable measurements in bitumen tanks—one of the toughest level applications in the oil industry. The antenna in the picture measures accurately and reliably despite having been exposed to blown bitumen, which is heated to over 220 °C (430 °F), for several months.



Measure accurately in old still-pipes

Use Rosemount 5900S with still-pipe array antenna and benefit from Low Loss Mode technology transmitting radar waves in the pipe center. This eliminates signal and accuracy degradation due to rust and product deposits inside the pipe.



Antennas for different tank types and applications

Parabolic

- Best choice in tanks without still-pipe
- Demanding environments with sticky or condensing liquids



Still-pipe array

- New or existing still-pipes
- Crude oil tanks with floating roofs
- Gasoline tanks with/without inner floating roof



LPG/LNG

- Pressurized or cryogenic/refrigerated liquefied gas
- Strong echo even under surface boiling conditions
- Measurement verification with closed tank via reference device



Horn/Cone

- For use in smaller nozzles without pipes
- From 4 in. to 8 in.



Level and overfill measurements in one powerful package

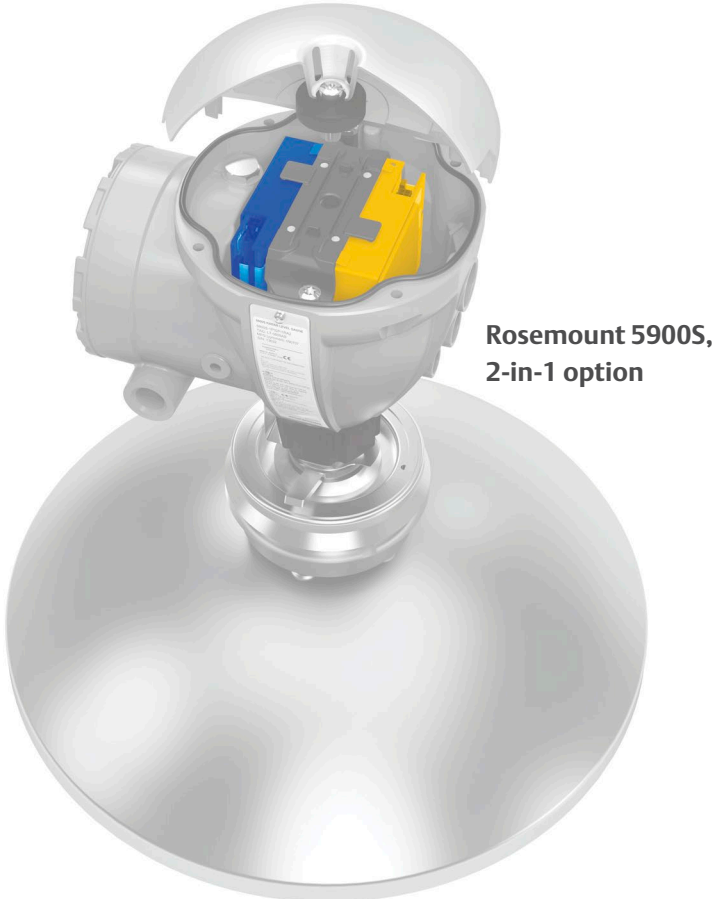

Rosemount 5900S, 2-in-1 option

Use two level gauges per tank

Dual radar-based tank gauging ensures inherent reliability as the gauges are always in operation, have no moving parts and no contact with the liquid.

The 5900S gauge with 2-in-1 technology provides dual level data in two independent layers of protection using only one housing and a single tank nozzle. The level output from the safety layer sensor is available as backup level measurement for day-to-day operations. Installation time is also reduced, not least in tanks with only one opening such as floating roof tanks with still-pipes and LPG tanks.

- Always in continuous operation
- No moving parts
- No contact with the liquid

Radar technology for critical operations



"We don't take any risks. A stop in operation is not an option, so we use radar level measurements utilizing the 2oo3 principle for safety and maintenance purposes."

- Benny Johansson, Terminal Manager, Gasum LNG Plant in Lysekil, Sweden

Temperature measurements for different needs



Highly accurate temperature data for net volume calculations

Use the ultra-stable Rosemount 2240S Temperature Transmitter with a temperature conversion accuracy of $\pm 0.05^\circ\text{C}$ ($\pm 0.09^\circ\text{F}$). It can be combined with a Rosemount 565/566/765 Multiple Spot Temperature Sensor with one to sixteen Pt-100 spot elements at different heights providing a tank temperature profile and average temperature.

Typically $\pm 0.025^\circ\text{C}$ ($\pm 0.045^\circ\text{F}$) accuracy is achieved with a calibrated four-wire sensor. The Rosemount 765 is in addition equipped with an integrated free water level sensor. The Rosemount 566 is designed specifically for cryogenic applications. These devices provide input for very accurate net volume calculations.

For single point temperature measurements, a Rosemount 644 temperature transmitter with a Rosemount 214C sensor can be used.

Cool-down control, leak and stratification detection for liquefied gas

The Rosemount 2240S temperature transmitter with Rosemount 614 spot sensors is used for temperature control:

- During start-up to measure inner wall and bottom temperature to avoid tank damage when it is filled for the first time with cryogenic/refrigerated liquid
- To detect leaks by continuously monitoring temperature in the insulation space between the inner and the outer tank wall. If temperature drops abnormally, plant operators are able to take action.

A Level Temperature and Density (LTD) profile device is used to detect stratification and provide data that can be used to prevent roll-over incidents.



Rosemount 2240S Multi-input Temperature Transmitter with a Rosemount 765 to the left, a Rosemount 565/566 in the middle, and a Rosemount 614 to the right.

Rosemount TankMaster™

Increase your power in tank inventory management

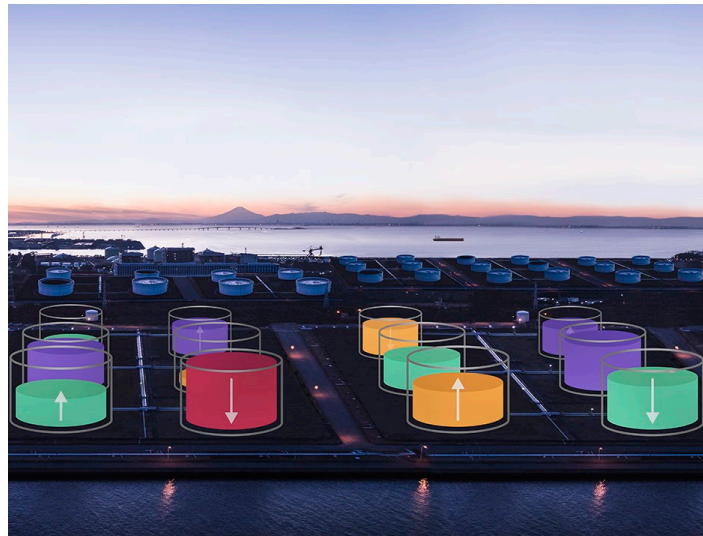

Use two level gauges per tank

Get a critical real-time overview of tank inventory and custody transfer data, and perform configuration, service and setup with the Rosemount TankMaster Inventory Management Software. Access information anywhere, at any time through the easy-to-use interface:

- Share data with users on all levels
- Make timely and better decisions
- Improve inventory accuracy

Operate tanks with full overview, calculate inventory and use custody transfer functions

- Base all net volume calculations on major industry standards such as API and ISO
- Rest assured that metrological data stay confidential
- See customized views with graphic plant layout
- Handle alarms via screen, e-mail or text message
- Use powerful batch handling to control transferred volumes
- Record and trace operations with audit logs and reporting
- Includes support for full containment refrigerated and cryogenic tanks including roll-over prediction features

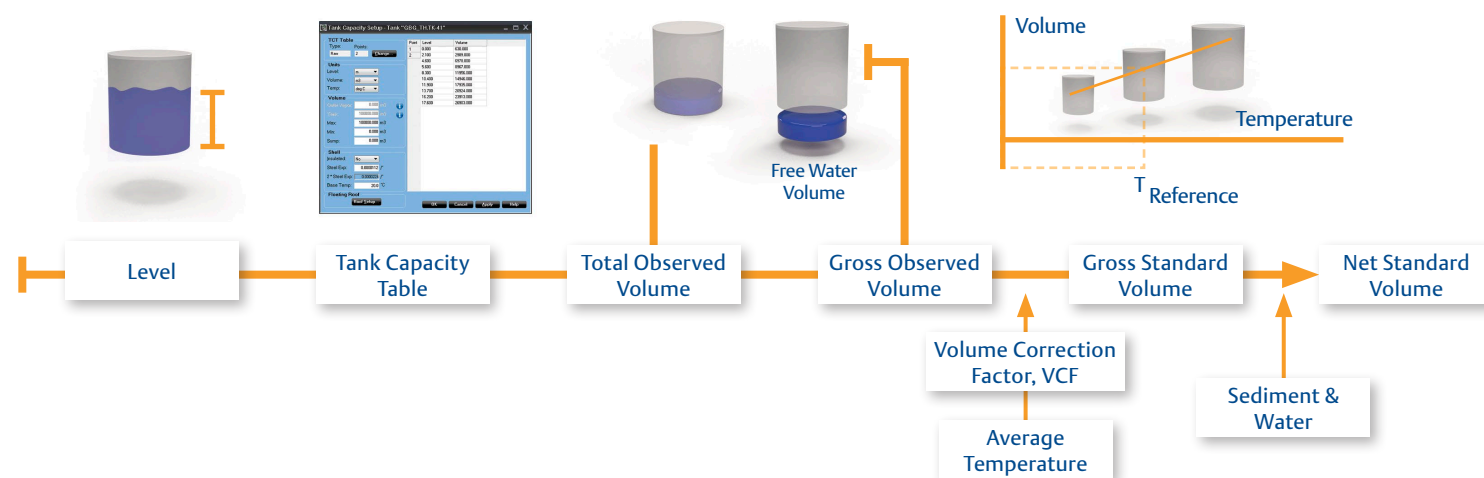

Always have data at hand

Rosemount TankMaster Mobile Inventory Management Software

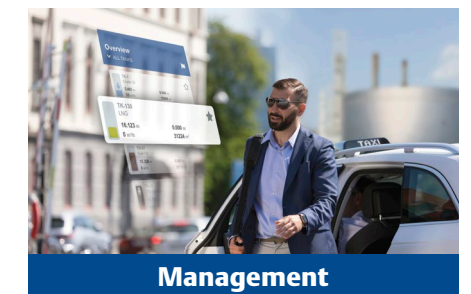

Rosemount TankMaster Mobile provides instant inventory overview as well as quick access to tank details. Gone are the days of siloed information that would not reach outside of the tank farm control room. Instead, shared inventory insight provides the opportunity to increase efficiency, drive productivity and improve communication throughout the supply chain. Rosemount TankMaster Mobile is easy to use and works seamlessly across smartphones, tablets, and computers:

- Modern, responsive, and easy-to-use
- Provides instant access to tank data from wherever you are
- Compliant with leading cybersecurity standards
- Integrates with existing Rosemount TankMaster Inventory Management Software



Integrate with legacy host systems, DCS and enterprise systems

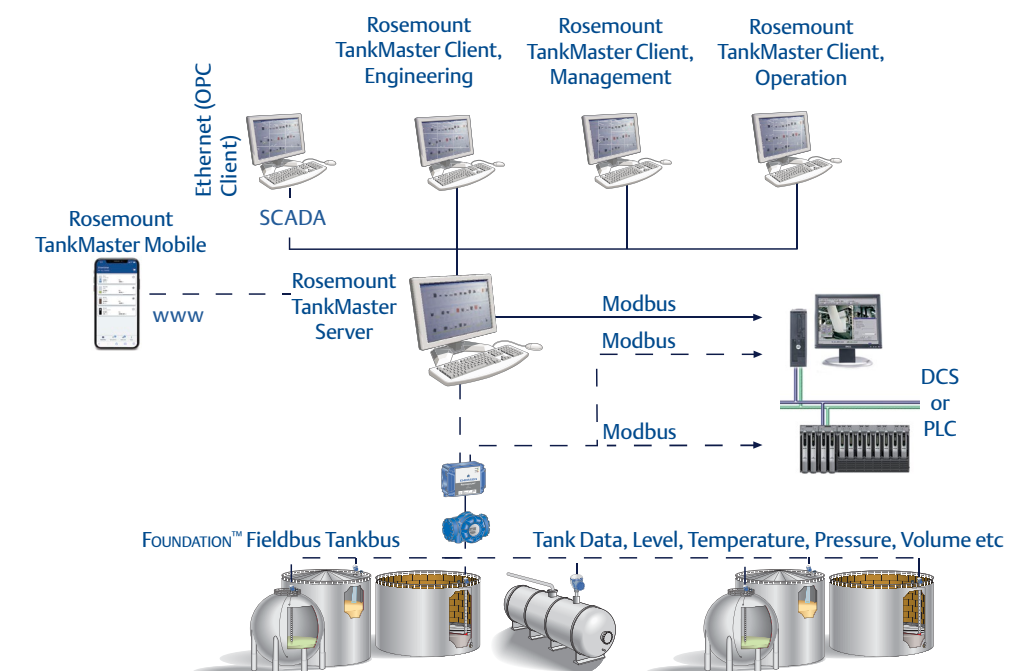

- Get OPC server with browser for easy interface
- Enable SCADA/DCS communication via Modbus and OPC
- Use TankMaster network with redundant server and client PCs
- Integrate with legacy tank gauging systems by taking in and displaying data from other vendors' gauges server and client PC

Taking safety to a higher level



Overfills occur in **1 out of 3300 fillings** worldwide

Source: Marsh and McLennan Companies

Meet ever increasing demands

Tank overfills are a major concern. Stored products are often hazardous, flammable and explosive. A future-proof safety system is vital to:

- Protect human lives, health, environment, and plant assets
- Ensure continuous overfill surveillance
- Comply with regulations e.g. API 2350 and IEC 61511
- Increase plant efficiency
- Minimize financial and legal risks

Improve safety and get improved efficiency

Tank overfills do not occur randomly, they are predictable and thereby preventable. Dual radar-based tank gauging lets you reach a higher level of safety than with traditional mechanical overfill prevention methods. Radar based level gauges are not in contact with the stored product, have no moving parts and are always in operation.

A safer terminal also pays off in economic terms in higher reliability and fewer costly interruptions. Accurate and continuous control of tank content also opens up for quicker transfers, better tank utilization, fewer visual inspections and longer intervals between proof-tests.

The first and most important line of defense is the basic process control system (BPCS) securing continuous surveillance of tank fills. The next level is an independent overfill prevention system serving as a second defense against overfills. On the top level, actions are added to mitigate the effects of any possible overfill.

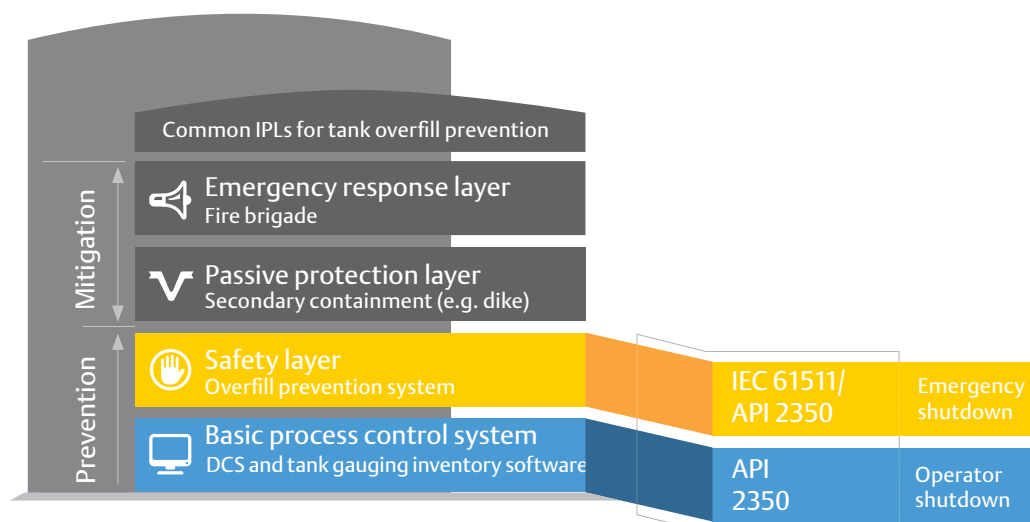

Real-life examples of why to invest in overfill safety

CONTAMINATION AND SPILL CLEAN-UP
WESTERN MASSACHUSETTS, UNITED STATES, 2005

23,000 gallons of diesel

were released to the secondary containment, consisting of a soil bottom and steel sides, as a result of human error.

9,000 gallons were lost and the groundwater contaminated.

TANK OVERFILL, EXPLOSION & FIRE
BUNCEFIELD, THE UK, 2005

\$ 1 Billion in damages

A tank was overfilled since both the servo gauge, and the mechanical HiHi alarm switch failed to work.

Spilled gas ignited, and caused an explosion and three days of fire with comprehensive legal consequences as a result

There are good reasons for good overfill prevention.

Hundreds of tank spills of hazardous liquids occur every day. These spills may affect the drinking water or, if exposed to an ignition source, result in an explosion with severe consequences for everybody involved.



"As our terminal is located in the New York metropolitan area, the Rosemount Tank Gauging System's reliability and overfill prevention capability are fundamental."

- **Craig Royston, General Manager, New York Terminals**

Automatic tank gauging and overfill prevention system

Benefit from the same high performance measurement solution

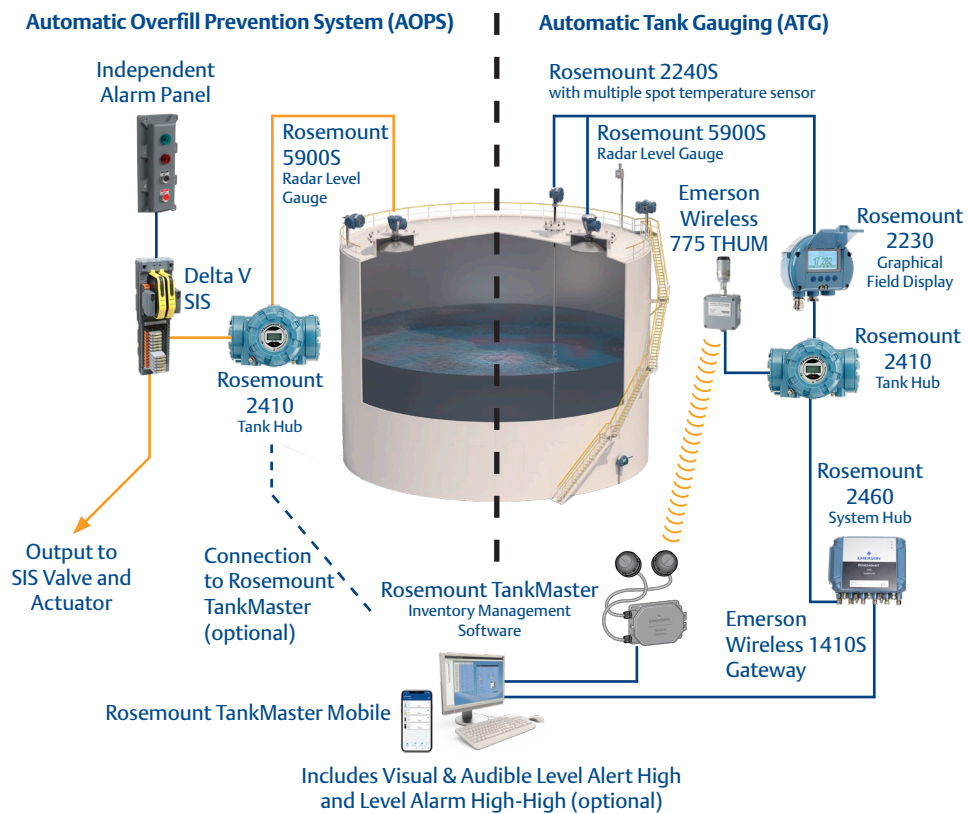

Use an automatic tank gauging system for basic control and overfill prevention

Use the Rosemount Tank Gauging System to create your basic process control system (BPCS) for high-performance tank monitoring and as the first independent protection layer in overfill prevention. It includes radar gauges, multiple spot temperature sensors, pressure transmitters, and inventory management software.

Connect radar level gauges to emergency shutdown devices and logic solvers for an overfill prevention solution in line with standards such as API 2350.

Use flexible level and overfill prevention solutions

Use for all different tank types

Get solutions for tank gauging and overfill prevention covering all storage tank types, stored product, and installation conditions.

Combine devices the way you want and achieve the desired level of safety

Rosemount Tank Gauging System supports everything from an independent additional level switch to a complete SIL 2 or SIL 3 automatic overfill prevention system (AOPS) including various level technologies. Using the same types of proven devices for tank gauging and overfill prevention simplifies training, procurement, parts handling, engineering and installation.

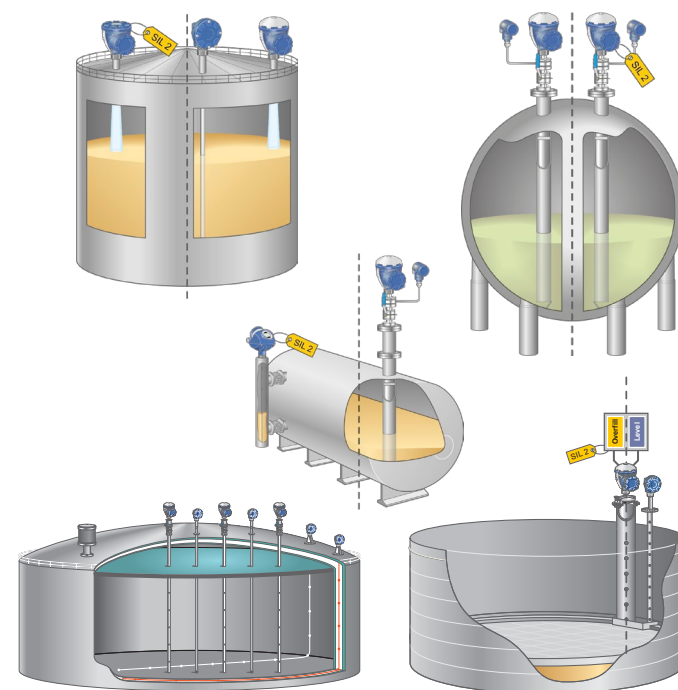

Radar level gauges for highest level and independent overfill prevention requirements

Rosemount 5900S for level, and Rosemount 5900S or 5900C for overfill prevention

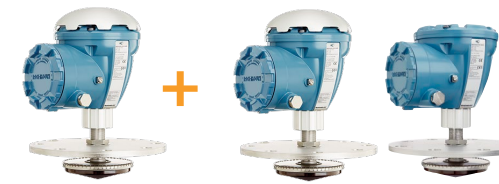

- Dual radar gauges for level and overfill measurements
- Each device is IEC 61508 certified SIL 2 capable
- Single device type minimizes need for training and spare parts

Rosemount 5900S 2-in-1 option for level, and overfill prevention



- Two radar gauges in one housing
- Independent level and overfill measurements
- Perfect choice for tanks with only one nozzle e.g. LPG tanks
- Certified IEC 61508 SIL 2 or SIL 3 capable

Radar level transmitters or switches for overfill prevention

Rosemount 5900S for level and Rosemount 5408 or 5300 for overfill prevention



- Radar gauge combined transmitter to reduce cost
- Independent level measurement and continuous high-level alarm
- Up to SIL 2 in non-redundant configurations

Rosemount 5900S for level, and Rosemount 2140 for overfill prevention

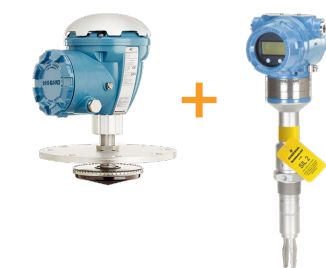

- Radar level gauge and point level switch
- Up to SIL 2 in non-redundant configurations

Perform proof-testing remotely

Safe and efficient proof-testing

The Rosemount 5900 Radar Level Gauge is designed with functionality that lets you proof-test high alarms and verify correct product surface measurement. Proof-testing can be done during normal operation.

The Rosemount TankMaster Inventory Management Software has advanced proof-testing support. The built-in proof-test manager allows operators to perform proof-testing of the overfill prevention system safely, and remotely from the control room.

A wizard guides you step by step to perform one or several comprehensive, or partial, proof-tests.

A detailed report is automatically generated and stored for each proof-test.



Reduce risks with floating roofs

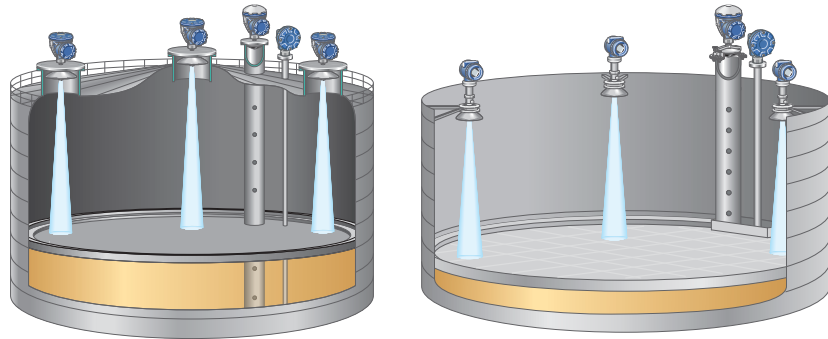

Up to six non-contacting radar transmitters are placed on top of the tank at equal distances. Roof tilt is tracked by comparing the distance between each radar gauge and the floating roof.

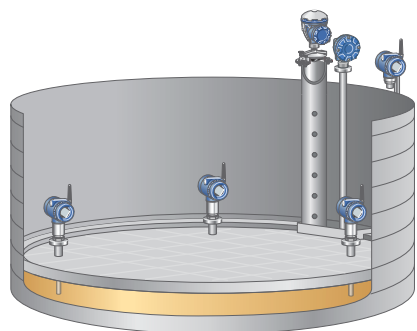

Up to six guided wave radar level transmitters are used with rigid probes. Roof tilt is tracked by comparing the distance from the floating roof down to the product surface.

Monitor roof conditions

A sinking, tilting, leaking or collapsing roof can cause mechanical damage, create overfills, and release explosive hydrocarbon vapor. The product in the tank may also become contaminated. Incorrectly mounted rim seals, leaking pontoons, overfills, strong winds, inadequate draining during heavy rain or snowfall, can dangerously affect buoyancy and roof position.

A floating roof monitoring function detects if the roof is stuck, sinking, floating higher or lower than normal, covered by water or product, or tilted. Three to six gauges may be used to track inclination. With one or two extra transmitters one can also detect if hydrocarbon is present on the tank roof or if the drain is plugged.

Upgrade your tank gauging easily

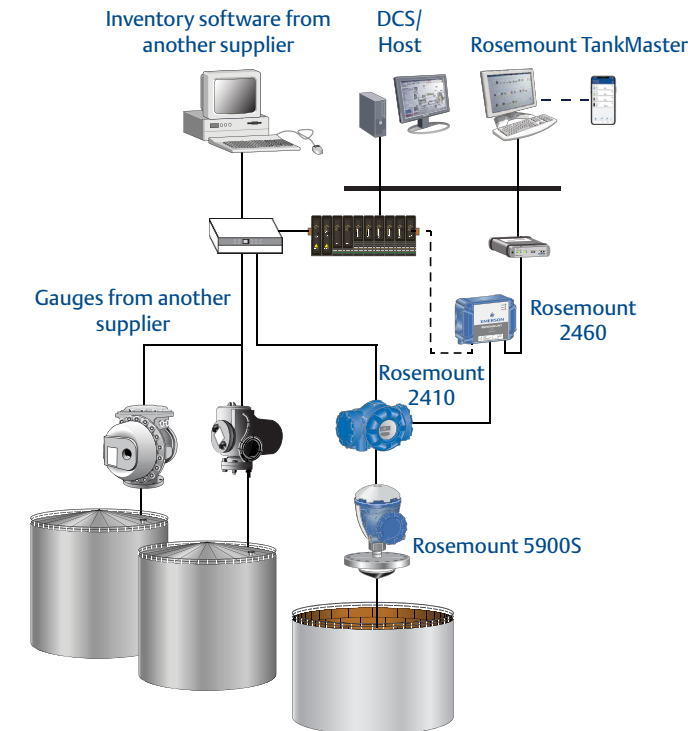

Emulation

- Make cost efficient step-by-step upgrades of existing equipment from any major supplier on the market
- Replace old or malfunctioning field and control room equipment seamlessly
- Use existing cabling and communication protocols for quick and easy installation
- Reduce maintenance costs for more efficient operation

Add Rosemount tank gauging devices to your existing system by emulating the previous vendor's field bus communication. Start by replacing old, obsolete, or malfunctioning equipment such as mechanical gauges or communication devices, with modern and reliable Rosemount Tank Gauging equipment. The existing host system will not see any difference since the new device imitates the old. Continue to upgrade incrementally as the budget allows.

Learn more and reach further



Emerson Services

Discuss the latest standards, get training programs and implement future-proof overfill prevention solutions together with Emerson. We offer services to assess a part of your tank farm, or all of it, to make sure it fulfills IEC 61511 or API 2350 or both.

A typical assessment comprises:

- Management system evaluation
- Risk assessment evaluation
- Tank and operations evaluation
- Compliance report with gap closure recommendations



Get "The Engineer's Guide to Level Safety Instrumentation and Overfill Prevention" from Emerson.com



Get the "Complete Guide to API 2350" from Emerson.com

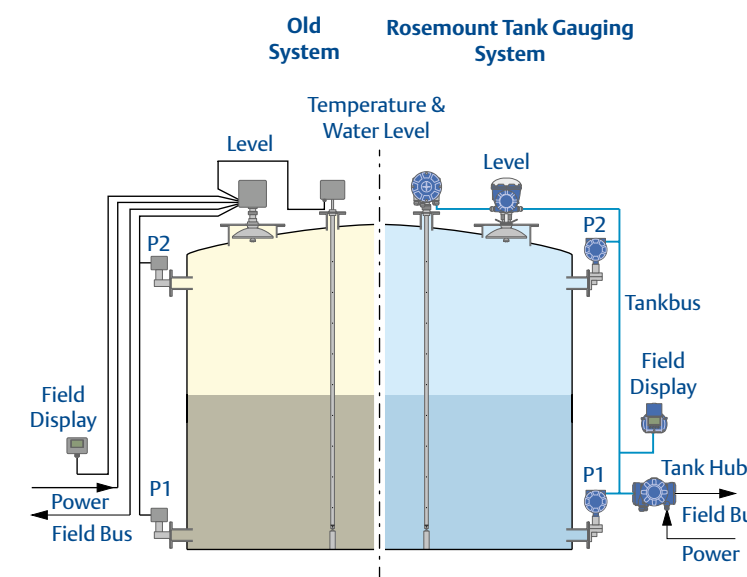

Reduce wiring costs on tanks

Use our two-wired bus-powered Tankbus, based on self-configuring FOUNDATION™ Fieldbus, for smooth and easy start-up. No expensive cable conduits are required as the tank units are intrinsically safe. Daisy-chain configuration reduces the need for junction boxes. Communicate with the control room via our Modbus based fieldbus, other major fieldbus standards or Emerson wireless transmission. All gauges, except for pressurized tanks, can be installed without taking the tank out of service.

Include wireless data transmission and enable automated tank farm operations

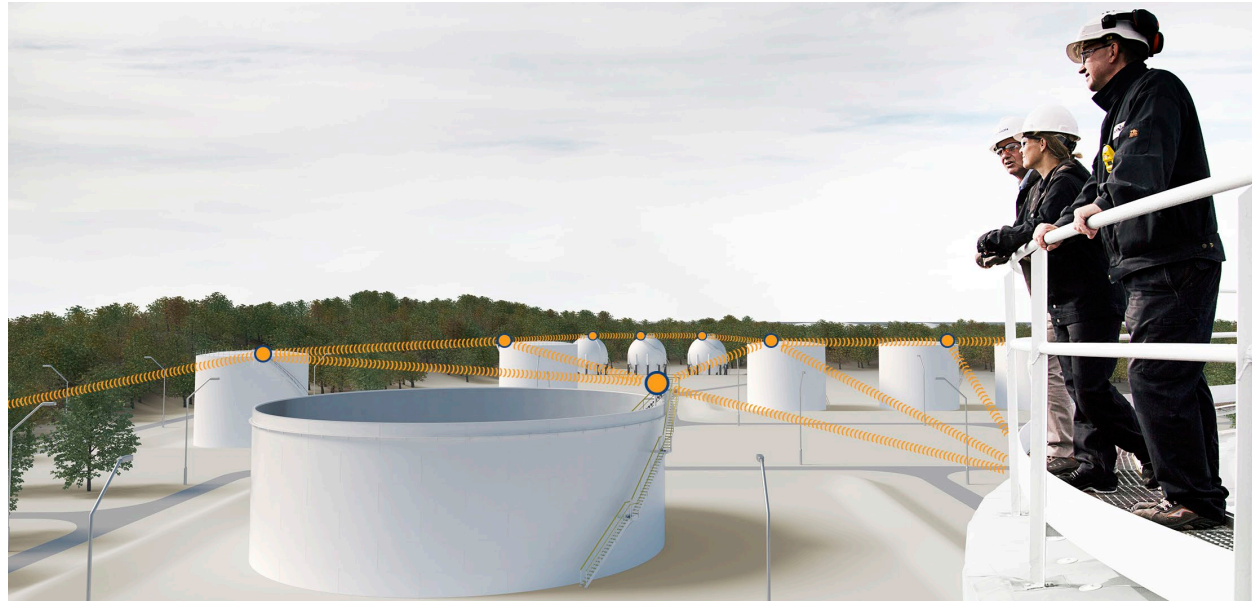

Wireless infrastructure can be scaled to meet your digital transformation roadmap:

- Eliminate the need for long distance field wiring
- Reduce installation cost by 70%
- Comply with regulations e.g. API 2350 and IEC 61511



A wireless tank gauging solution designed specifically for your bulk liquid storage plant maximizes safety and operational performance. With unique radar technology and ultra-high temperature precision, you get best-in-class tank gauging.

The Emerson Wireless 775 THUM™ Adapter is integrated in a connection box that can be installed away from the Rosemount 2410 Tank Hub.

When distances and topological conditions are challenging
The attractive investment cost means you can connect previously isolated tanks, divided by water, roads or other obstacles.

When installation or replacement of wiring is a safety concern
Digging for new cables can be complicated and dangerous. Wireless tank gauging reduces risk by delivering data to the control room without unnecessary excavation work and cabling.

When time is critical, deadlines are tight and resources scarce
Expansion, upgrading and maintenance projects take time but wireless tank gauging is a plug-and-play solution when you want to minimize downtime and get a quick start-up.

When you want to reduce cost and complexity
Replacing or maintaining cables that are outdated and in poor condition can be expensive. The use of wireless instruments means less installation work and wiring as well as fewer junction boxes and conduits. In addition, no detailed site surveys are required, and you reduce engineering and drawing work.

When you want to automate your tank farm
Emerson's open architecture allows you to easily add wireless devices e.g. pressure, temperature, level, flow, vibration, and leak detection instruments, discrete switches, valve and regulator position monitors, enabling automation of tank farm functions.

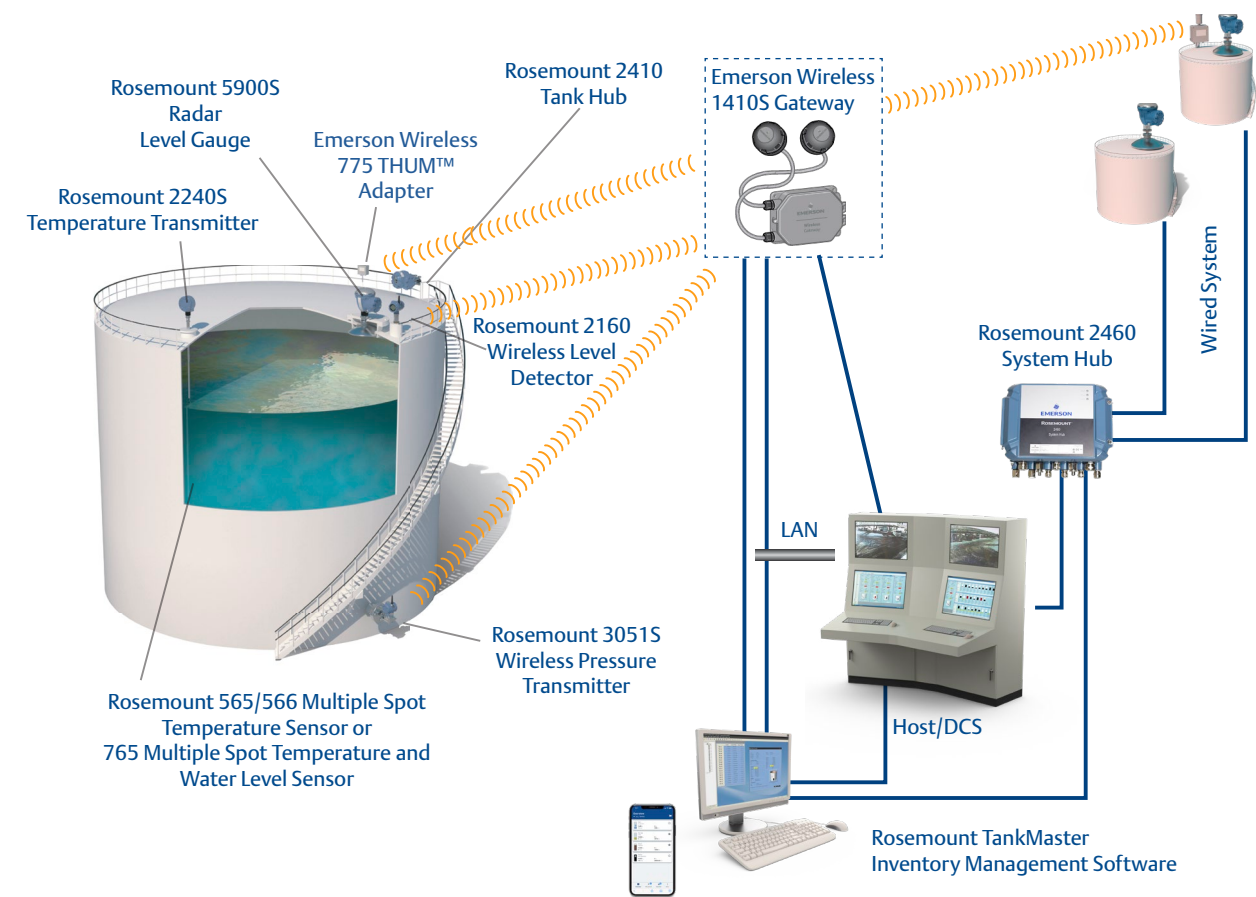

WirelessHART™

The Emerson wireless solution is based on IEC 62591 (*WirelessHART*®), the open industry standard for wireless field networks. The self-organizing mesh network adjusts to changes in the field and ensures uninterrupted data communication. Each wireless node can relay data around obstacles. Reliability actually increases with network size.



"When the cost of replacing old cabling is estimated at one million euros, it's time to research alternatives. Wireless communication was our choice. Since oil movement is the core business of our company, we also wanted the most reliable and safe system for just-in-time delivery to refineries."

**-Mr. Massimo Diminich,
Technical Assets Manager, SIOT/TAL, Italy**

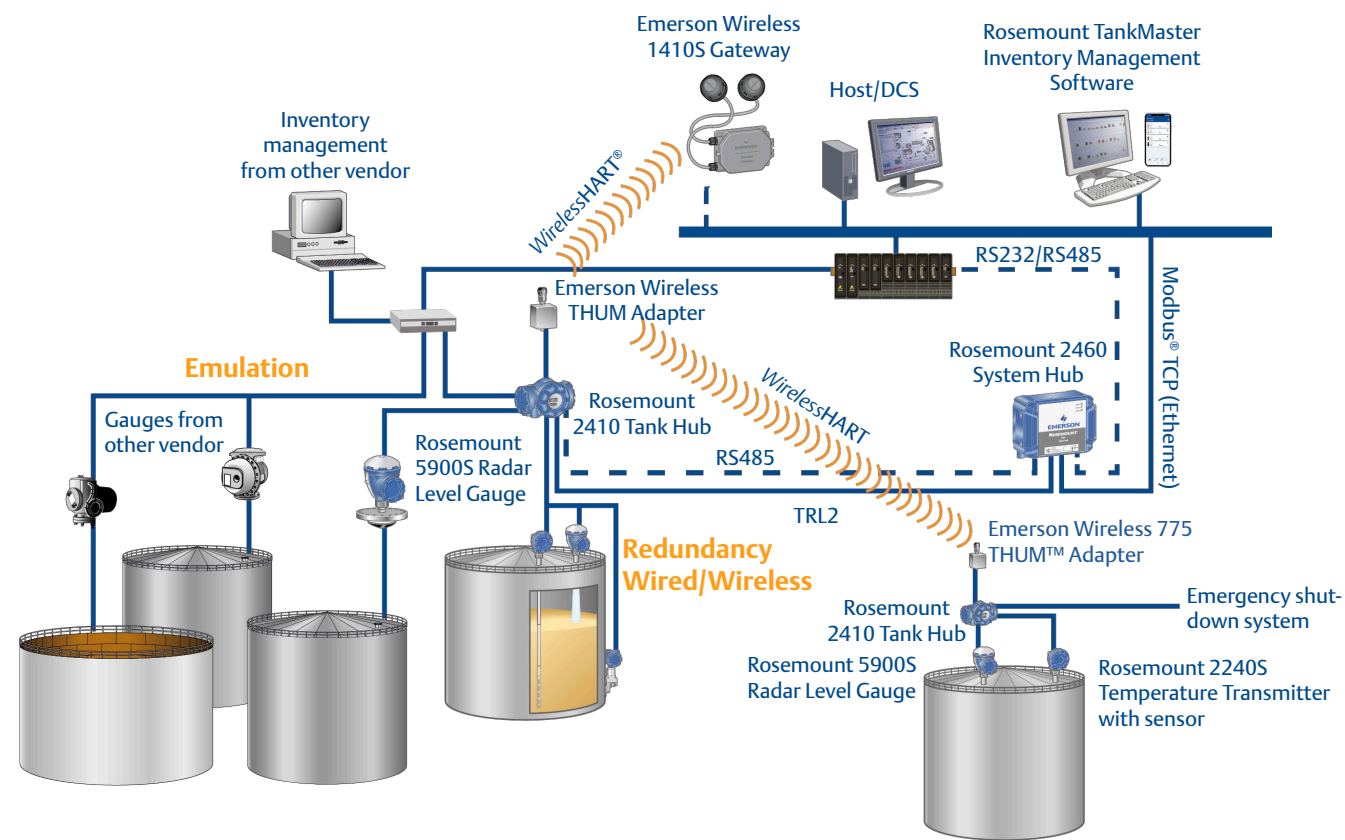

Proven and reliable technologies you can trust

Emerson's wireless tank gauging solutions are based on IEC 62591 (*WirelessHART*) which is an open standard enabling you to include devices in your network for different applications and from different suppliers. Wired and wireless networks can co-exist in a completely customized tank gauging network solution. Transferred data is secured by encryption, authentication, verification, anti-jamming and reliable key management.

The gateway automatically identifies all active nodes. There is no need for line-of-sight between gateway and devices since all devices act as mesh network nodes, and can relay data. The wireless signals easily find their way around obstacles. If distances are long, it is possible to use a repeater device. Emerson has a supporting network planning software tool, the easy-to-use AMS Snap-on, which can be used to secure a best-practice, solid network. Your wireless tank gauging system works equally well as a wired for functional safety in SIL applications systems.

Gain more data in emulation applications

Add a wireless communication interface to gain full capacity that:

- Works in parallel with the wired emulation protocol
- Gives more measurement data and advanced diagnostics
- Enables remote radar gauge configuration and calibration functionality
- Offers new and modern protocols to host/DCS system

Get the most out of communication redundancy

Wireless and wired communication in combination provide a safe and cost-efficient way to meet requirements for communication redundancy, providing two independent data paths to the host/DCS. Using wireless for tank gauging data means the existing field cabling can be used for other purposes. For example, if you need to get both tank gauging data and a high level alarm signal back to the control room, but only have one single set of wiring available to the tank.

Wireless tank gauging field devices

Rosemount 5900S Radar Level Gauge



- Use together with Rosemount 2410 and Emerson Wireless 775 THUM Adapter for wireless capabilities
- Benefit from the same ± 0.5 mm (0.02 in.) high accuracy
- Available in SIL 2 or SIL 3 versions
- Use 2-in-1 option for dual measurement data

Rosemount 2410 Tank Hub with Emerson Wireless 775 THUM Adapter



- Hub: provides power, transfers tank data from field devices, and calculates average temperature, density and volume – supports many communication options including *WirelessHART*
- THUM: Wireless data link between the gauge/tank hub and the gateway

Wireless network units

Emerson Wireless 1410S Gateway



- Network manager providing an interface between field devices and the Rosemount TankMaster software or DCS/Host system in the control room
- Available with antenna options for different installation needs and network sizes

Rosemount 702 Wireless Discrete Dual Input or Output Transmitter



- Relays data and is used as a repeater in the wireless tank gauging system
- Easy to install with SmartPower solutions providing up to 10 years of maintenance free operation
- Battery replacement without removing the transmitter

Wireless level transmitter and switches

Rosemount 3308



- Used as a cost-efficient alternative to Rosemount 5900 gauges when a separate overfill prevention device is needed
- Equipped with cut-to-fit probes in field

Rosemount 2160



- Used when a separate alarm switch is required to prevent overfill situations in fixed roof tanks
- Features continuous health/self-checking of the fork, and has all the features as of wired level switches without complication and cost of wiring

Complete system solutions for storage of liquefied gas in full containment tanks

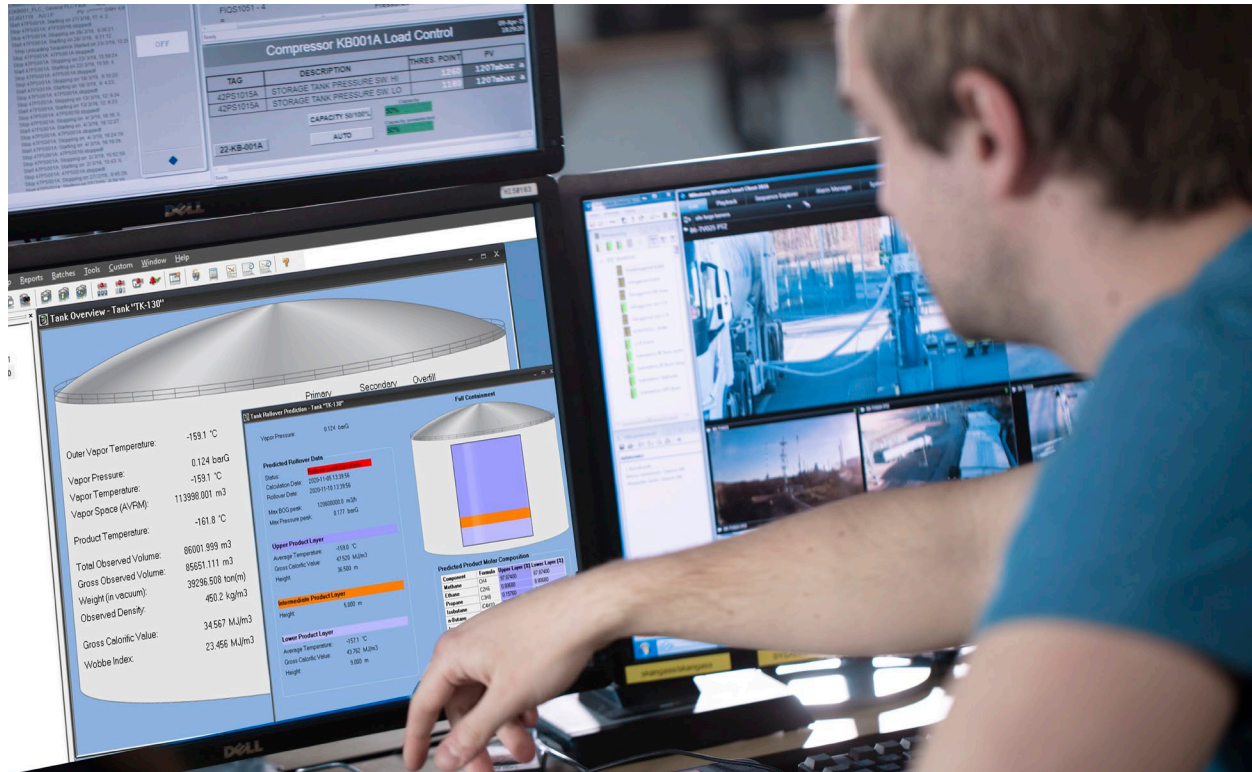

In cryogenic and refrigerated tanks, it is critical to have measurements that will not fail:

- Use reliable radar technology for level measurements and overfill prevention
- Identical separation reduces complexity and the likelihood of human errors
- Remote proof-testing from the control room saves time and improves safety

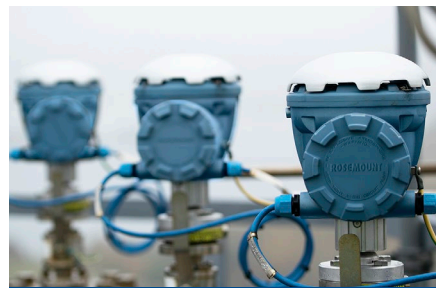

Reliability is critical in refrigerated storage applications. 2oo3 voting with triple redundancy is a common solution for level measurements.

Radar offers highly accurate and reliable level measurements
This technology is particularly suitable in cryogenic/refrigerated gas applications where in-tank maintenance is only possible at scheduled maintenance periods which are several years apart.

Multiple spot temperature measurements for inventory calculations. Measurements also complement data from the level, temperature and density device (LTD) to provide a density and temperature profile for stratification detection in the tank. This data is used for calculations to determine the risk of a roll-over incident which could cause large uncontrolled vapor emissions and even severe tank damage. Rosemount TankMaster has extensive support for stratification monitoring, roll-over prediction, and it includes reporting features.

Temperature transmitter and sensors for cool-down control and leak detection:

- Inner tank wall and bottom temperature is measured during the first fill.
- By monitoring temperature in the insulation space between the inner and outer tank wall a potential leak can be detected.

Typical system configuration for cryogenic and refrigerated storage

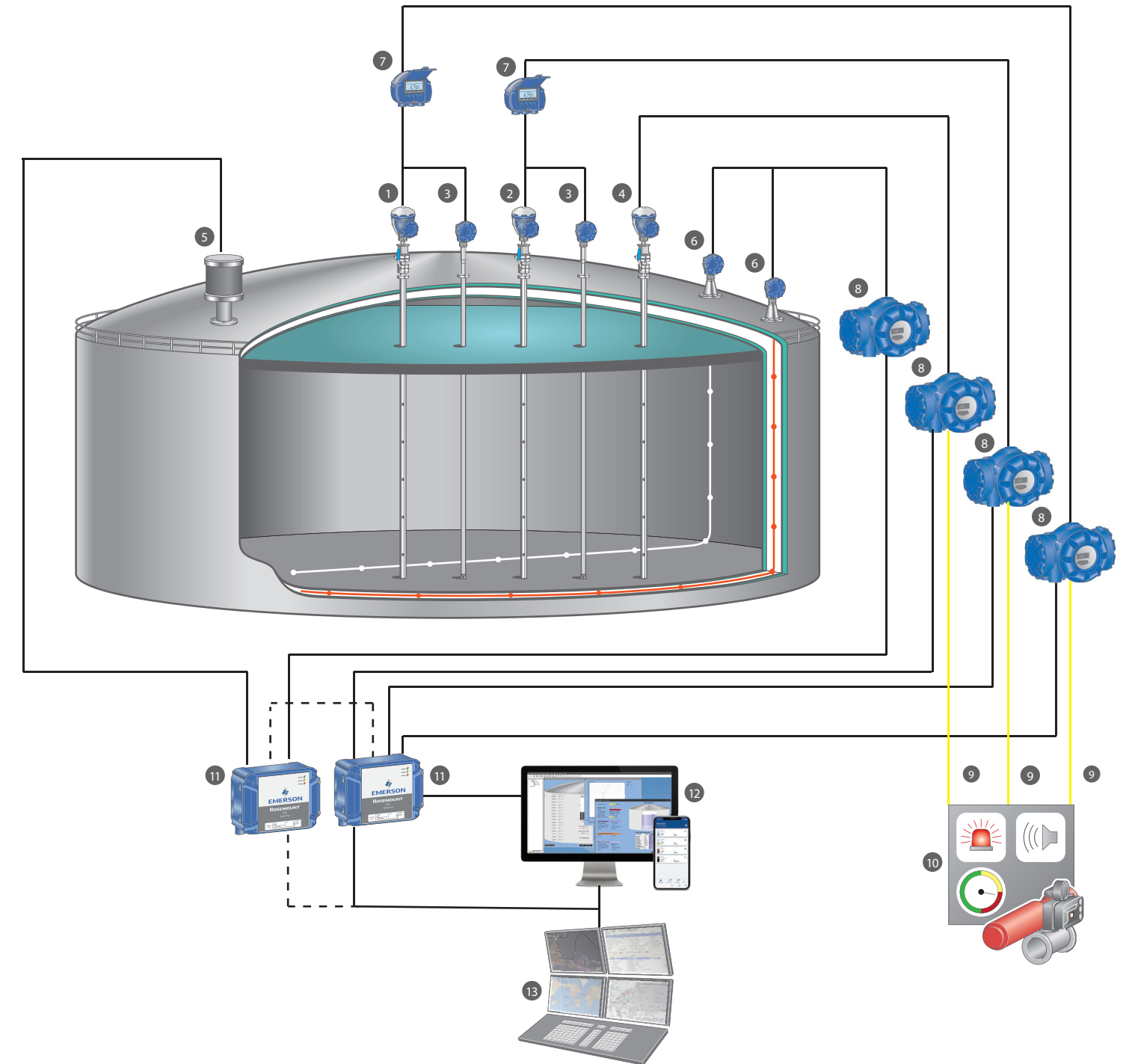

- | | | |
|---|---|---|
| 1 Rosemount 5900S (primary level gauge) | 5 Level, Temperature, and Density (LTD) Gauge for stratification detection | 9 SIL 2/SIL 3 relay or 4-20 mA alarm signal |
| 2 Rosemount 5900S (secondary level gauge) | 6 Rosemount 2240S temperature transmitter with Rosemount 614 cryogenic spot sensor for cool-down and leak detection | 10 Independent alarm panel |
| 3 Rosemount 2240S temperature transmitter with Rosemount 566 cryogenic multiple spot temperature sensor | 7 Rosemount 2230 Graphical Field Display | 11 Rosemount 2460 System Hub |
| 4 Rosemount 5900S (independent continuous level alarm) | 8 Rosemount 2410 Tank Hub | 12 Rosemount TankMaster Software |
| | | 13 DCS/Host system |

Count on the best in business

The pioneer in radar based tank gauging

- ... for marine tankers
- ... for on-shore tanks with custody transfer accuracy
- ... with emulation functionality
- ... with 2-in-1 and 3-in-1 functionality
- ... with wireless communications
- ... with 2-in-1 and SIL 3 safety
- ... with automated calibration of four-wire temperature sensors
- ... enabling inventory insight from any location/device

Put your trust in the inventor of radar tank gauging who installed the first radar level gauge in 1975 and today delivers more tank gauging systems worldwide than anyone else. We introduced the world's first tank gauging system, and we continue breaking new ground...

Talk to our people in technical and sales support and get access to knowledge from highly trained service engineers in more than 80 countries.

- Use products and people from the world market leader
- Benefit from decades of experience in radar tank gauging
- Secure availability to high-quality service and support

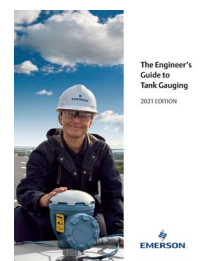

Get "The Engineer's Guide to Tank Gauging" from Emerson.com



Learn more

Get in touch with your local sales representative if you have any questions or want to book a meeting.

Find your local representative at <https://www.emerson.com/en-us/contact-us>



Works everywhere

Use the Rosemount Tank Gauging System from Emerson for all kinds of tanks: pressurized and non-pressurized, with fixed or floating roofs, with or without still-pipes.

The picture to the left shows jet fuel storage at Los Angeles International Airport (LAX) using a Rosemount 5900S radar level gauge with an 8-inch still-pipe.

Examples of applications:

- Refineries
- Tank terminals
- Fuel depots
- Liquefied gas storage
- Distilleries
- Chemical storage
- Food and beverage

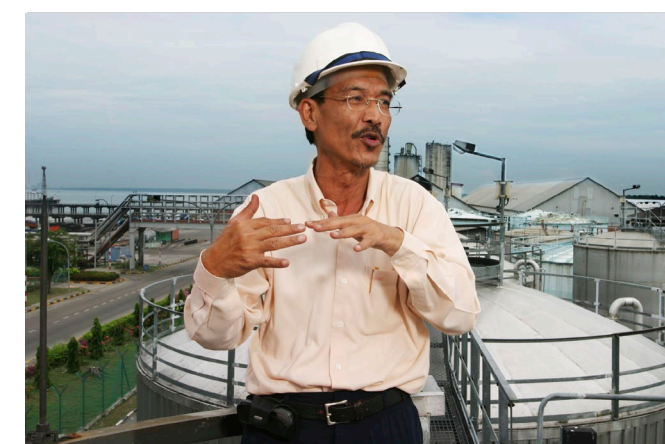





"To save time, we sometimes load seven tanks on a ship at the same time. Rosemount TankMaster gives us uninterrupted online level data – necessary to do things right."

-Mr. Nor Bin Taib, General Manager, Port Klang Terminal, Malaysia

Emerson supports customers with innovative technologies and expertise to address your toughest measurement challenges to achieve top quartile performance.



-  [Emerson.com/Rosemount-Tank Gauging](https://www.emerson.com/Rosemount-Tank-Gauging)
-  [Facebook.com/EmersonAutomationSolutions](https://www.facebook.com/EmersonAutomationSolutions)
-  [LinkedIn.com/company/Emerson-Automation-Solutions](https://www.linkedin.com/company/Emerson-Automation-Solutions)
-  [Twitter.com/EMR_Automation](https://twitter.com/EMR_Automation)

Before using Emerson products, it is important that you review the health and safety information, and other information regarding the limitations of our products, contained in the applicable user manuals located at www.emerson.com.

The Emerson logo is a trademark and service mark of Emerson Electric Co. Rosemount is a mark of one of the Emerson family of companies. All other marks are the property of their respective owners. ©2021 Emerson Electric Co. All rights reserved.

00803-0100-5100 Rev CA



CONSIDER IT SOLVED™